

**FPU® SYSTEMS OPERATION MANUAL
(INCLUDING REPAIR PARTS & SPECIAL TOOL LIST)
STANDARD AND SPECIALIZED FPU MODULES
BOH FPU Field Pack-up Units**

CHAPTER 6

PARTS SUPPORTING INFORMATION

This page was intentionally left blank

PARTS SUPPORTING INFORMATION

FPU SYSTEMS OPERATION MANUAL
(INCLUDING REPAIR PARTS & SPECIAL TOOL LIST)
STANDARD AND SPECIALIZED FPU MODULES
BOH FPU Field Pack-up Units

INTRODUCTION TO MAINTENANCE ALLOCATION CHART (MAC)

INTRODUCTION

BOH Environmental LLC Recommended MAC

This introduction provides a general explanation of all maintenance and repair functions authorized at various maintenance levels under the standard Army Maintenance System concept.

The MAC (WP 0033 00, Table 1, immediately following the introduction) designates overall authority and responsibility for the performance of maintenance functions on the FPU SYSTEMS. The application of the maintenance functions to the FPU SYSTEMS shall be consistent with the capacities and capabilities of the designated maintenance levels, which are shown on the MAC in column (4) as:

Unit – includes two sub columns, C (operator/crew) and O (unit) maintenance.

Direct Support – includes an F sub column.

General Support – includes an H sub column.

Depot – includes a D sub column.

Maintenance Functions

Maintenance functions are limited to and defined as follows:

1. **Inspect:** To determine the serviceability of an item by comparing its physical and mechanical characteristics with established standards through examination (e.g., by sight, sound, or feel). This includes scheduled inspections.
2. **Test:** To verify serviceability by measuring the mechanical characteristics of an item and comparing those characteristics with prescribed standards on a scheduled basis, i.e., load testing of lift devices and hydrostatic testing of pressure hoses.
3. **Service:** Operations required periodically to keep an item in proper operating condition; e.g., to clean (includes decontaminate, when required), to preserve, to drain, to paint, or to replenish fuel, lubricants, chemical fluids, or gases.
4. **Adjust:** To maintain or regulate, within prescribed limits, by bringing into proper position, or by setting the operating characteristics to specific parameters.
5. **Align:** To adjust specified variable elements of an item to bring about optimum or desired performance.
6. **Calibrate:** To determine and cause corrections to be made or to be adjusted on instruments of test, measuring, and diagnostic equipment used in precision measurement. Consists of comparisons of two instruments, one of which is a certified standard of known accuracy, to detect and adjust any discrepancy in the accuracy of the instrument being compared.

7. Remove/Install: To remove and install the same item when required to perform service or other maintenance functions. Install may be the act of emplacing, seating, or fixing into position a spare, repair part, or module (component or assembly) in a manner to allow the proper functioning of an equipment or system.
8. Replace: To remove an unserviceable item and install a serviceable counterpart in its place. "Replace" is authorized by the MAC and assigned maintenance level is shown as the third position code of the Source, Maintenance and Recoverability (SMR) code.
9. Repair: The application of maintenance services, including fault location-Troubleshooting, removal/installation, disassembly/assembly procedures, and maintenance actions to identify troubles and restore serviceability to an item by correcting specific damage, fault, malfunction, or failure in a part, subassembly, module (component or assembly), end item, or system.

NOTE

The following definitions are applicable to the "REPAIR" maintenance functions of Service, Inspect, Test, Adjust, Align, Calibrate, and/or Replace:

Fault location-Troubleshooting – The process of investigating and detecting the cause of equipment malfunctioning; the act of isolating a fault within a system or Unit Under Test (UUT).

Disassembly/Assembly – The step-by-step breakdown (taking apart) of a spare/functional group coded item to the level of its least component, that is assigned an SMR code for the level of maintenance under consideration (i.e., identified as maintenance significant).

Actions – Welding, grinding, riveting, straightening, facing, machining, and/or resurfacing.

10. Overhaul: That maintenance effort (service/action) prescribed to restore an item to a completely serviceable/operational condition as required by maintenance standards in appropriate technical publications. Overhaul is normally the highest degree of maintenance performed by the Army. Overhaul does not normally return an item to like new condition.
11. Rebuild: Consists of those services/actions necessary for the restoration of unserviceable equipment to a like new condition in accordance with original manufacturing standards. Rebuild is the highest degree of materiel maintenance applied to Army equipment. The rebuild operation includes the act of returning to zero those age measurements (e.g., hours/miles) considered in classifying Army equipment/components.

Explanation of Columns in the MAC

Column (1) – Group Number. Column (1) lists Functional Group Code (FGC) numbers, the purpose of which is to identify maintenance significant components, assemblies, subassemblies, and modules with the Next Higher Assembly (NHA).

Column (2) – Component/Assembly. Column (2) contains the item names of components, assemblies, subassemblies, and modules for which maintenance is authorized.

Column (3) – Maintenance Function. Column (3) lists the functions to be performed on the item listed in column (2). (For a detailed explanation of these functions refer to “Maintenance Functions” outlined above).

Column (4) – Maintenance Level. Column (4) specifies each level of maintenance authorized to perform each function listed in column (3), by indicating work time required (expressed as man-hours in whole hours or decimals) in the appropriate sub column. This work time figure represents the active time required to perform that maintenance function at the indicated level of maintenance. If the number or complexity of the tasks within the listed maintenance function varies at different maintenance levels, appropriate work time figures are to be shown for each level. The work time figure represents the average time required to restore an item (assembly, subassembly, component, module, end item, or system) to a serviceable condition under typical field operating conditions. This time includes preparation time (including any necessary disassembly/assembly time), troubleshooting/fault location time, and quality assurance time in addition to the time required to perform the specific tasks identified for the maintenance functions authorized in the MAC. The symbol designations for the various maintenance levels are as follows:

- **C – Operator or crew maintenance**
- **O– Unit maintenance**
- **F – Direct Support maintenance**
- **L – Specialized repair activity (SRA)**
- **H – General support maintenance**
- **K – Commercial depot maintenance**

NOTE

The "L" maintenance level is not included in column (4) of the MAC. Functions to this level of maintenance are identified by a work time figure in the "H" column of column (4), and an associated reference code is used in the REMARKS column (6). This code is keyed to the remarks and the SRA complete repair application is explained there.

Column (5) – Tools and Equipment Reference Code. Column (5) specifies, by code, those common tool sets (not individual tools), common Test, Measurement and Diagnostic Equipment (TMDE), and special tools, special TMDE and special support equipment required to perform the designated function. codes are keyed to the entries in the tools and test equipment table (WP 0033 00, Table 2).

Column (6) – Remarks Code. When applicable, this column contains a letter code, in alphabetical order, which is keyed to the remarks table entries (WP 0033 00, Table 3).

END OF WORK PACKAGE

This page was intentionally left blank

PARTS SUPPORTING INFORMATION

**FPU SYSTEMS OPERATION MANUAL
(INCLUDING REPAIR PARTS & SPECIAL TOOL LIST)
STANDARD AND SPECIALIZED FPU MODULES
BOH FPU Field Pack-up Units**

INTRODUCTION TO REPAIR PARTS & SPECIAL TOOL LIST

(1) Group Number	(2) Component/Assembly	(3) Maintenance Function	(4) Maintenance Level					(5) Tools and Equipment Ref Code	(6) Remarks
			Unit		Direct Support	General Support	Depot		
			C	O	F	H	D		
00	FPU MODULE SYSTEM								
01	STANDARD MODULES CLASS 1 THROUGH 6								
0101	CLASS 1 Module	INSPECT	0.5	0.5					
		SERVICE		0.5					
		REPLACE		0.2					
0102	CLASS 2 Module	INSPECT	0.5	0.5					
		SERVICE		0.2					
		REPLACE		0.2					
0103	CLASS 3 Module	INSPECT	0.5	0.5					
		SERVICE		0.2					
		REPLACE		0.2					
0104	CLASS 4 Module	INSPECT	0.5	0.5					
		SERVICE		0.2					
		REPLACE		0.2					
0105	CLASS 5 Module	INSPECT	0.5	0.5					
		SERVICE		0.2					
		REPLACE		0.2					
0106	CLASS 6 Module	INSPECT	0.5	0.5					
		SERVICE		0.2					
		REPLACE		0.2					

0032 00-1

(1) Group Number	(2) Component/Assembly	(3) Maintenance Function	(4) Maintenance Level					(5) Tools and Equipment Ref Code	(6) Remarks
			Unit		Direct Support	General Support	Depot		
			C	O	F	H	D		
0107	Module Drawers and Bearing Slide	INSPECT	0.5	0.5					
		SERVICE		0.2					
		REPLACE		0.5					
0108	Standard/Specialized Module Casters	INSPECT	0.5	0.5					
		REPLACE		0.5					
02	SPECIALIZED MODULES								
0201	SHORT HELO Module	INSPECT	0.1	0.1					
		SERVICE		0.5					
		REPLACE		0.2					
020101	Cage	INSPECT	0.1	0.1					
		REPLACE		0.5					
020102	Cabinet Drawers	INSPECT		0.1					
		SERVICE		0.2					
		REPLACE		0.2					
		REPAIR		0.5	1				
020103	Drawers Bearing Slides	INSPECT		0.1					
		SERVICE		0.2					
		REPLACE		0.2					
		REPAIR		0.5	1				
020104	Drawer Divider Sets	Replace		0.5					
0202	Weapons Module	INSPECT		0.1					
		SERVICE		0.2					
		REPLACE		0.2					
		REPAIR		0.5	1				

(1) Group Number	(2) Component/Assembly	(3) Maintenance Function	(4) Maintenance Level					(5) Tools and Equipment Ref Code	(6) Remarks
			Unit		Direct Support	General Support	Depot		
			C	O	F	H	D		
020201	Drawers Bearing Slides	INSPECT		0.1					
		SERVICE		0.2					
		REPLACE		0.2					
		REPAIR		0.5	1				
020202	Door assembly	INSPECT		0.1					
		SERVICE		0.2					
		REPLACE		0.2					
		REPAIR		0.5	1				
020203	Door Seals	INSPECT		0.1					
		SERVICE		0.2					
		REPLACE		0.2					
		REPAIR		0.5	1				
020204	Drawer Rifle M16A2	INSPECT		0.1					
		SERVICE		0.2					
		REPLACE		0.2					
		REPAIR		0.5	1				
020205	Drawer Rifle M4/M16	INSPECT		0.1					
		SERVICE		0.2					
		REPLACE		0.2					
		REPAIR		0.5	1				
020206	Drawer Bulk	INSPECT		0.1					
		SERVICE		0.2					
		REPLACE		0.2					
		REPAIR		0.5	1				
020207	Drawer Pistol 9mm	INSPECT		0.1					
		SERVICE		0.2					
		REPLACE		0.2					
		REPAIR		0.5	1				

(1) Group Number	(2) Component/Assembly	(3) Maintenance Function	(4) Maintenance Level					(5) Tools and Equipment Ref Code	(6) Remarks
			Unit		Direct Support	General Support	Depot		
			C	O	F	H	D		
0203	Flammable/Corrosive Module	INSPECT		0.1					
		SERVICE		0.2					
		REPLACE		0.2					
020301	Door assembly	INSPECT		0.1					
		SERVICE		0.2					
		REPLACE		0.2					
		REPAIR		0.5	1				
020302	Door Seals	INSPECT		0.1					
		SERVICE		0.2					
		REPLACE		0.2					
		REPAIR		0.5	1				
020303	Drawer Assemblies	SERVICE		0.2					
		REPLACE		0.2	1				
020304	Standard/Specialized Module Casters	INSPECT	0.5	0.5					
		REPLACE		0.5					
0204	FPU BULK MODULE #1 THROUGH #4	INSPECT	0.2	0.2					
		SERVICE	0.2						
		REPLACE	0.5						
		ALIGN	1						
		REPAIR			1				
020401	FPU BULK Chassis	INSPECT	0.2	0.2					
		SERVICE	0.2						
		REPLACE	0.5						
		ALIGN	4						
		REPAIR			1				

(1)	(2)	(3)	(4)					(5)	(6)
Group Number	Component/Assembly	Maintenance Function	Maintenance Level					Tools and Equipment Ref Code	Remarks
			Unit		Direct Support	General Support	Depot		
			C	O	F	H	D		
020402	Tray 1000 lb.	INSPECT	0.2	0.2					
		SERVICE	0.2						
		REPLACE	0.5						
		ALIGN	1						
		REPAIR							
020403	Bin Cargo 1000 lb. 8" deep	INSPECT	0.2	0.2					
		SERVICE	0.2						
		REPLACE	0.5						
		ALIGN	1						
		REPAIR		1					
020404	Bin Adapter Kit	INSPECT	0.2						
		SERVICE	0.2						
		REPLACE	0.5						
03	TRICON CONTAINER ADAPTER								
0301	TRICON Container Adapter Hardware	INSPECT	0.2	0.2					
		SERVICE		0.2					
		REPLACE		0.5					
0302	TRICON Module Kits #1 through #6	INSPECT	0.5	0.5					
		SERVICE		0.5					
		REPLACE		0.2					
		ALIGN	1						
		REPAIR			1				

END OF WORK PACKAGE

This page was intentionally left blank

PARTS SUPPORTING INFORMATION

FPU SYSTEMS OPERATION MANUAL (INCLUDING REPAIR PARTS & SPECIAL TOOL LIST) STANDARD AND SPECIALIZED FPU MODULES BOH FPU Field Pack-up Units

INTRODUCTION TO REPAIR PARTS & SPECIAL TOOL LIST

INTRODUCTION

SCOPE

This Repair Parts & Special Tools List (RPSTL) lists and authorizes spares and repair parts; special tools; special test, measurement, and diagnostic equipment (TMDE); and other special support equipment required for performance of Operator, Unit, and Direct Support maintenance of the Field Pack Up system (FPU SYSTEMS). It authorizes the requisitioning, issue, and disposition of spares, repair parts, and special tools as indicated by the Source, Maintenance, and Recoverability (SMR) codes.

GENERAL

In addition to the introduction work package, this RPSTL is divided into the following work packages:

1. **Repair Parts List Work Packages.** Work packages containing lists of spares and repair parts authorized by this RPSTL for use in the performance of maintenance. These work packages also include parts which must be removed for replacement of the authorized parts. Parts lists are composed of functional groups in ascending alphanumeric sequence, with the parts in each group listed in ascending figure and item number sequence. Sending units, brackets, filters, and bolts are listed with the component they mount on. Bulk materials are listed by item name in FIG. Repair parts kits are listed separately in their own functional group and work package. Repair parts for reparable special tools are also listed in a separate work package. Items listed are shown on the associated illustrations.
2. **Cross-Reference Indexes Work Packages.** There are two cross-reference index work packages in this RPSTL: the National Stock Number (NSN) Index work package and the Part Number (P/N) Index work package. The National Stock Number Index work package refers you to the figure and item number. The Part Number Index work package refers you to the figure and item number.

EXPLANATION OF COLUMNS IN THE REPAIR PARTS LIST

ITEM NO. (Column (1)). Indicates the number used to identify items called out in the illustration.
NSN (Column (2)). The NSN for the item is listed in this column.

CAGEC (Column (3)). The Commercial and Government Entity Code (CAGEC) is a five-digit code which is used to identify the manufacturer, distributor, or Government agency/activity that supplies the item.

PART NUMBER (Column (4)). Indicates the primary number used by the manufacturer (individual, company, firm, corporation, or Government activity), which controls the design and characteristics of the item by means of its engineering drawings, specifications, standards, and inspection requirements to identify an item or range of items.

NOTE

When you use an NSN to requisition an item, the item you receive may have a different P/N from the number listed.

DESCRIPTION AND USABLE ON CODE (UOC)

(Column (5)). This column includes the following information:

The ITEM/Assembly Progression (.Item or Assembly, ..Next Lower Item, ...Next Lower Item)

1. The federal item name, and when required a minimum description to identify the item.
2. P/Ns of bulk materials are referenced in this column in the line entry to be manufactured or fabricated.
3. Hardness Critical Item (HCI). A support item that provides the equipment with special protection from electromagnetic pulse (EMP) damage during a nuclear attack.
4. The statement END OF FIGURE appears just below the last item description in column (6) for a given figure in both the repair parts list and special tools list work packages.

QTY (Column (6)). The QTY (quantity per figure) column indicates the quantity of the item used in the breakout shown on the illustration/figure, which is prepared for a functional group, sub-functional group, or an assembly. A "AR (as required)" appearing in this column instead of a quantity indicates that the quantity is variable and quantity may change from application to application.

EXPLANATION OF CROSS-REFERENCE INDEX WORK PACKAGES FORMAT AND COLUMNS.

1. National Stock Number (NSN) Index Work Package.

STOCK NUMBER Column. This column lists the NSN in National Item Identification Number (NIIN) sequence. The NIIN consists of the last nine digits of the NSN.

NSN
(e.g., 5385-01-574-1476)

When using this column to locate an item, ignore the first four digits of the NSN. However, the complete NSN should be used when ordering items by stock number.

FIG. Column. This column lists the number of the figure where the item is identified/located. The figures are in numerical order in the repair parts list and special tools list work packages.

ITEM Column. The item number identifies the item associated with the figure listed in the adjacent FIG. Column. This item is also identified by the NSN listed on the same line.

2. **Part Number (P/N) Index Work Package.** P/Ns in this index are listed in ascending alphanumeric sequence (vertical AIDS of letter and number combinations which places the first letter or digit of each group in order A through Z, followed by the numbers 0 through 9 and each following letter or digit in like order).

PART NUMBER Column. Indicates the P/N assigned to the item.

FIG. Column. This column lists the number of the figure where the item is identified/located in the repair parts list and special tools list work packages.

ITEM Column. The item number is the number assigned to the item as it appears in the figure referenced in the adjacent figure number column.

SPECIAL INFORMATION

UOC The UOC appears in the lower left corner of the Description Column heading. Usable On Codes are shown as "UOC: . . ." in the Description Column (justified left) on the first line under the applicable item/nomenclature. Non coded items are applicable to all models. Identification of the UOCs used in this RPSTL are:

NOTE

The FPU Module System is designed to be used in any of the following Container Models

CODE	Used On
F1A	Model FPU-8-2/BOH CARGO 12-1 GREEN–Forest Green
F1B	Model FPU-8-2/BOH CARGO 12-1 TAN – Desert Sand
F2C	Model FPU-20-1 GREEN – Forest Green
F2D	Model FPU-20-1 TAN – Desert Sand
F2E	Model FPU-20-2 GREEN – Forest Green
F2F	Model FPU-20-2 TAN – Desert Sand
F3A	Model BOH-CARGO-12-1 GREEN – Forest Green
F3B	Model BOH-CARGO-12-1 TAN – Desert Sand
F3C	Model FPU-8-2 GREEN – Forest Green
F3D	Model FPU-8-2 TAN-Desert Sand
FAB	Model FPU-8-4/BOH-CARGO-12-3 GREEN-Forest Green
FAC	Model FPU-8-4/BOH CARGO 12-3 TAN-Desert Sand
FAC	Model FPU-20-3 GREEN – Forest Green
FAD	Model FPU-20-3 TAN – Desert Sand

Fabrication Instructions. Bulk materiel required to manufacture items are listed in the bulk materiel functional group of this RPSTL. Part numbers for bulk materiel are also referenced in the Description Column of the line item entry for the item to be manufactured/fabricated. Detailed fabrication instructions for items source Coded to be manufactured or fabricated are found in: Not Applicable.

Index Numbers. Items which have the word BULK in the figure column will have an index number shown in the item number column. This index number is a cross-reference between the NSN and P/N index work packages and the bulk materiel list in the repair parts list work package.

Illustrations List. The illustrations in this RPSTL contain unit and direct support authorized items. The tabular list in the repair parts list work package contains only those parts coded "O" and "F" in the third position of the SMR code; therefore, there may be a break in the item number sequence.

HOW TO LOCATE REPAIR PARTS

A. When NSNs or P/Ns Are Not Known.

1. Using the table of contents, determine the assembly group to which the item belongs. This is necessary since figures are prepared for assembly groups and subassembly groups, and lists are divided into the same groups.
2. Find the figure covering the functional group or the sub functional group to which the item belongs.
3. Identify the item on the figure and note the number(s).
4. Look in the repair parts list work packages for the figure and item numbers. The NSNs and part numbers are on the same line as the associated item numbers.

B. When NSN Is Known.

1. If you have the NSN, look in the STOCK NUMBER column of the NSN index work package. The NSN is arranged in NIIN sequence. Note the figure and item number next to the NSN.
2. Turn to the figure and locate the item number. Verify that the item is the one you are looking for.

C. When the P/N Is Known.

1. If you have the P/N and not the NSN, look in the PART NUMBER column of the P/N index work package. Identify the figure and item number.
2. Look up the item in the figure of the applicable repair parts list work package.

END OF WORK PACKAGE

PARTS SUPPORTING INFORMATION

**FPU SYSTEMS OPERATION MANUAL
(INCLUDING REPAIR PARTS & SPECIAL TOOL LIST)
STANDARD AND SPECIALIZED FPU MODULES
BOH FPU Field Pack-up Units**

STANDARD MODULES

STANDARD MODULES PARTS FOR CLASS 1 THRU 6

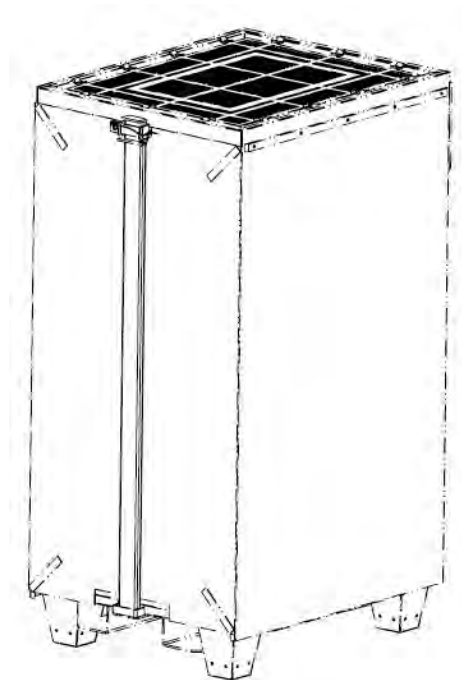

STANDARD MODULES PARTS FOR CLASS 1 THRU 6

FIGURE #01 through #24

STANDARD MODULES EXTERIOR PARTS FOR CLASS 1 THRU 6

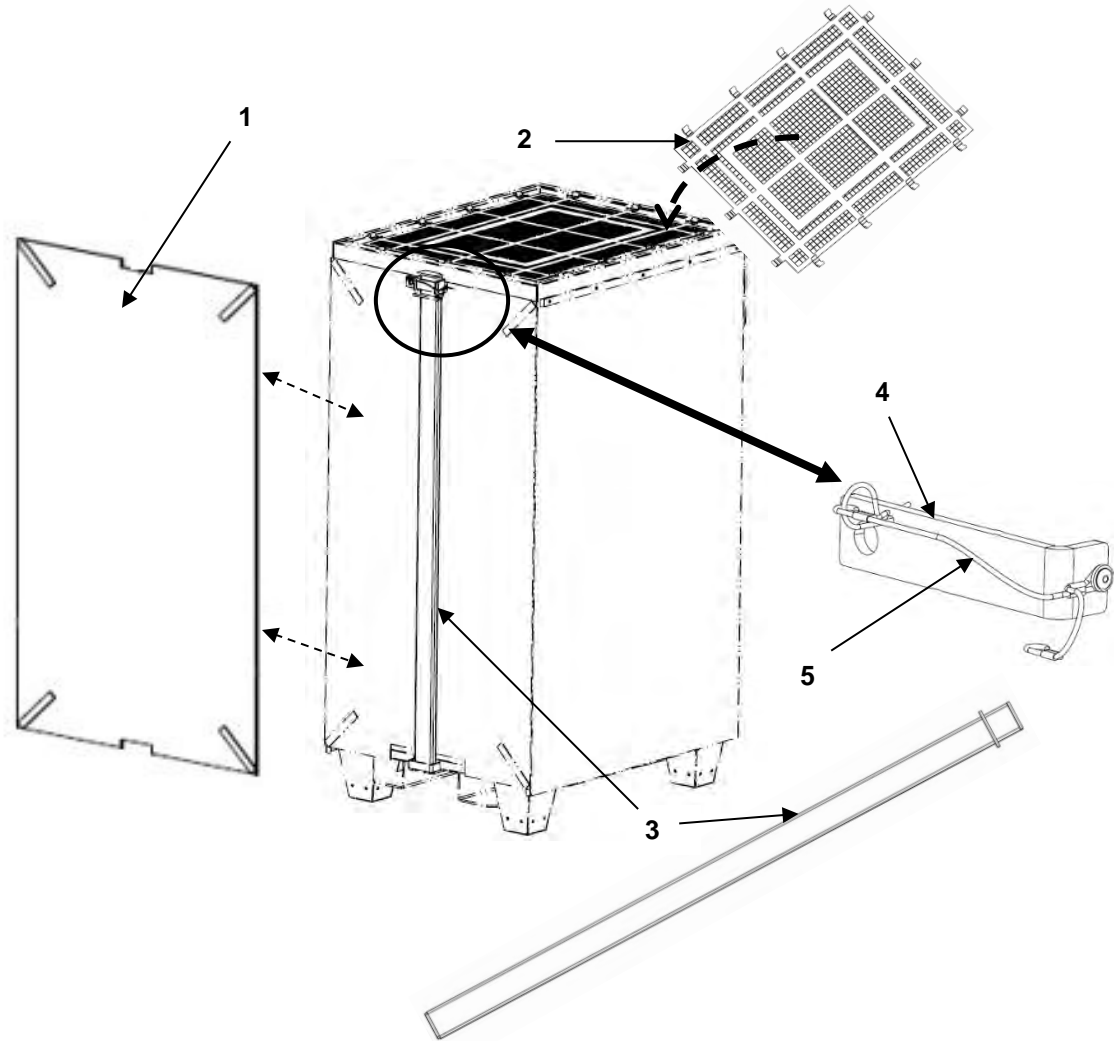
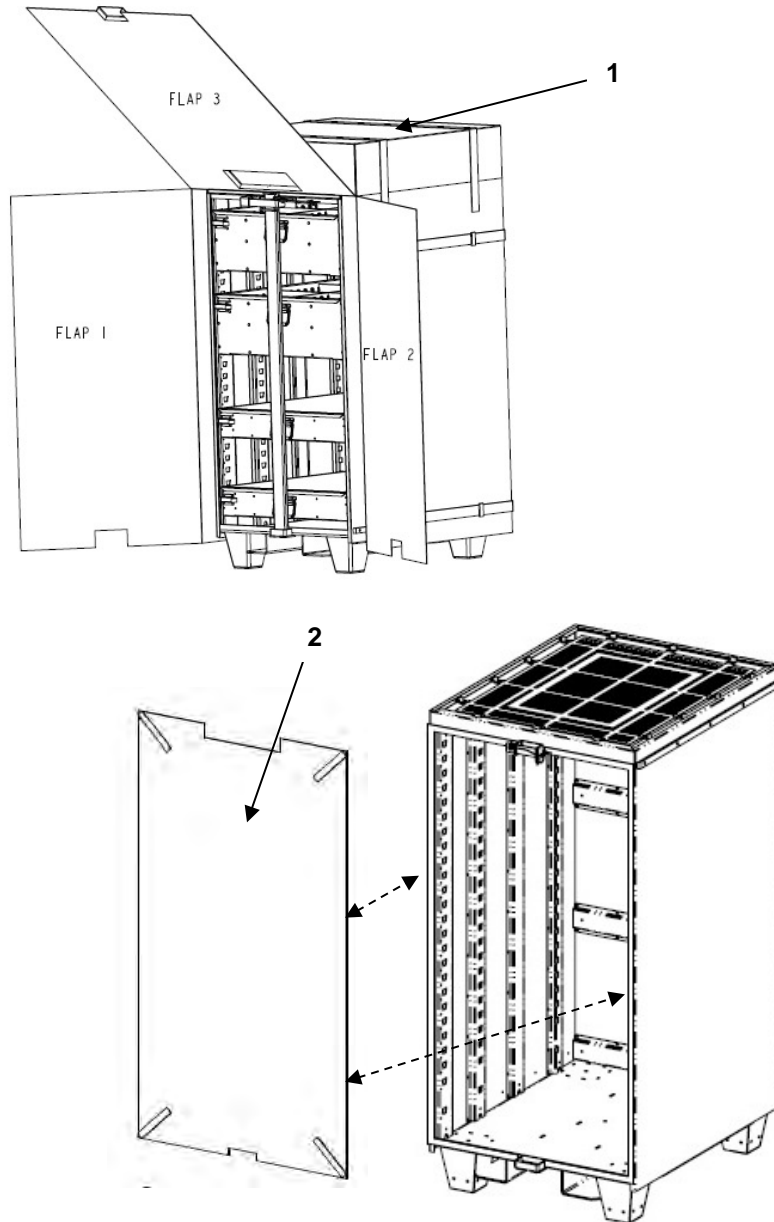

FIGURE 01 STANDARD MODULE EXTERIOR PARTS CLASS 1 THRU 6
THESE PARTS ARE PROVIDED ON ALL STANDARD MODULES

(1) ITEM NO.	(2) NSN	(3) CAGEC	(4) PART NUMBER	(5) DESCRIPTION AND USABLE ON CODE (UOC)	(6) QTY
				GROUP 01 FIGURE 01 STANDARD MODULE EXTERIOR PARTS Class 1 thru 6	
1	NOT ASSIGNED	1NSG3	15522002	. WEATHER COVER 4 1/2" CUTOUT BLACK	1
2	NOT ASSIGNED	1NSG3	15522021	.NET	1
3	8145-01-502-2630	1NSG3	16061017-001	.SECURITY 3G BAR GREEN	1
4	NOT ASSIGNED	1NSG3	15988248-001	..BAR LOCK W/HARDWARE GREEN	1
5	NOT ASSIGNED	1NSG3	15120662	...LANYARD W/HITCH PIN ASSY	1
1	NOT ASSIGNED	1NSG3	15522002	. WEATHER COVER 4 1/2" CUTOUT BLACK	1
2	NOT ASSIGNED	1NSG3	15522021	.NET	1
3	8145-01-502-2630	1NSG3	16061017-002	.SECURITY 3G BAR TAN	1
4	NOT ASSIGNED	1NSG3	15988248-002	..BAR LOCK W/HARDWARE TAN	1
5	NOT ASSIGNED	1NSG3	15120662	...LANYARD W/HITCH PIN ASSY	1
END OF FIGURE 01					

OPTIONAL WEATHER COVERS CLASS 1 THRU 6



Note
Drawers removed for clarity

FIGURE 02 OPTIONAL WEATHER COVERS CLASS 1 THRU 6

0034 00-4

(1) ITEM NO.	(2) NSN	(3) CAGEC	(4) PART NUMBER	(5) DESCRIPTION AND USABLE ON CODE (UOC)	(6) QTY
				GROUP 01 FIGURE 02 OPTIONAL WEATHER COVERS Class 1 thru 6	
1	8145-01-523-4076	1NSG3	15522004	. WEATHER SLIP COVER BLACK	1
2	NOT ASSIGNED	1NSG3	15522009	. WEATHER COVER 12 ½" CUTOUT BLACK	1
END OF FIGURE 02					

STANDARD MODULES CLASS #1

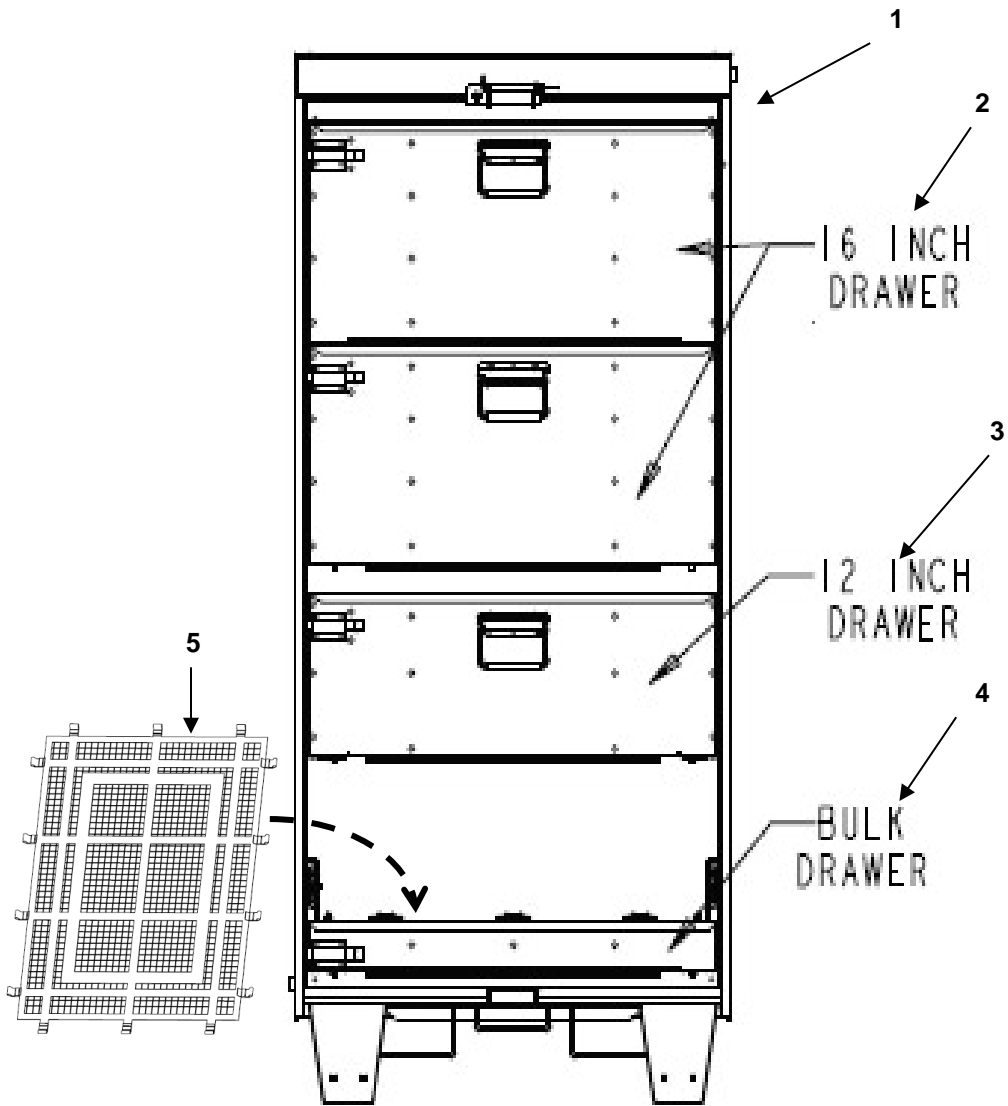

FIGURE 03 STANDARD MODULE #9 CLASS 1
COVER AND RETAINING BAR REMOVED FOR CLARITY

(1) ITEM NO.	(2) NSN	(3) CAGEC	(4) PART NUMBER	(5) DESCRIPTION AND USABLE ON CODE (UOC)	(6) QTY
				GROUP 0101 FIGURE 03 STANDARD Class 1 MODULE #9	
1	8145-01-523-4003	1NSG3	15700009-001	.MODULE #9 GREEN	1
2	8145-01-473-1527	1NSG3	15700016-001	..16" DRAWER GREEN with SLIDES and STD Dividers	2
3	8145-01-473-1275	1NSG3	15521200-001	..12" DRAWER GREEN with SLIDES and STD Dividers	1
4	8145-01-473-1283	1NSG3	15520001-001	..BULK DRAWER GREEN with SLIDES and NET	1
5	NOT ASSIGNED	1NSG3	15522023	...BULK DRAWER NET	1
1	8145-01-523-4003	1NSG3	15700009-002	.MODULE #9 TAN	1
2	8145-01-473-1527	1NSG3	15700016-002	..16" DRAWER TAN with SLIDES and STD Dividers	2
3	8145-01-473-1275	1NSG3	15521200-002	..12" DRAWER TAN with SLIDES and STD Dividers	1
4	8145-01-473-1283	1NSG3	15520001-002	..BULK DRAWER TAN with SLIDES and NET	1
5	NOT ASSIGNED	1NSG3	15522023	...BULK DRAWER NET	1
END OF FIGURE 03					

STANDARD MODULES CLASS 1

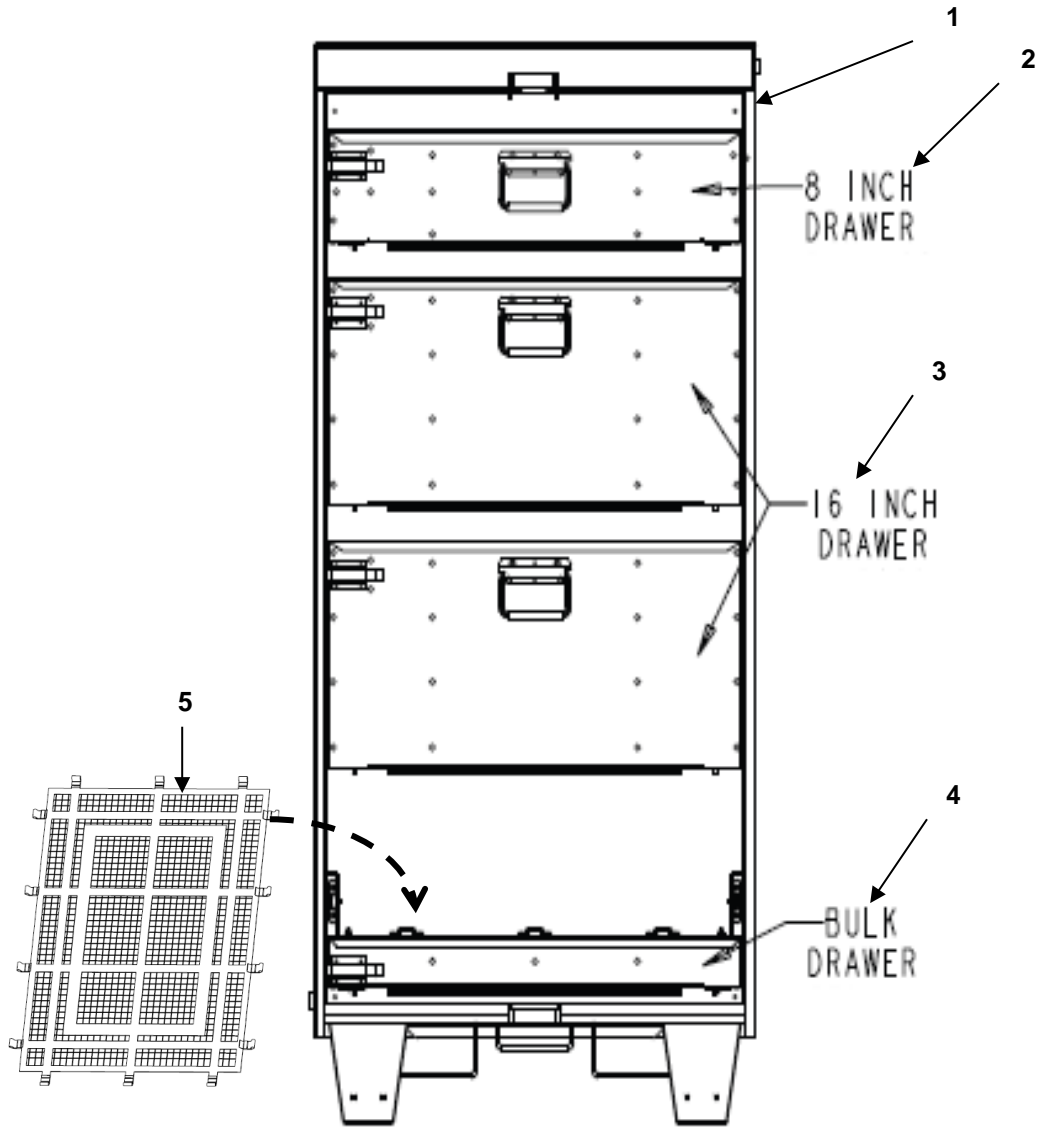

FIGURE 04 STANDARD MODULE #8 CLASS 1
COVER AND RETAINING BAR REMOVED FOR CLARITY

0034 00-8

(1) ITEM NO.	(2) NSN	(3) CAGEC	(4) PART NUMBER	(5) DESCRIPTION AND USABLE ON CODE (UOC)	(6) QTY
				GROUP 0101 FIGURE 04 STANDARD Class 1 MODULE #8	
1	8145-01-523-4000	1NSG3	15700008-001	..MODULE #8 GREEN	1
2	8145-01-473-1226	1NSG3	15520800-001	..8" DRAWER GREEN with SLIDES and STD Dividers	1
3	8145-01-473-1527	1NSG3	15700016-001	..16" DRAWER GREEN with SLIDES and STD Dividers	2
4	8145-01-473-1283	1NSG3	15520001-001	..BULK DRAWER GREEN with SLIDES and NET	1
5	NOT ASSIGNED	1NSG3	15522023	...BULK DRAWER NET	1
1	8145-01-523-4000	1NSG3	15700008-002	..MODULE #8 TAN	1
2	8145-01-473-1226	1NSG3	15520800-002	..8" DRAWER TAN with SLIDES and STD Dividers	1
3	8145-01-473-1527	1NSG3	15700016-002	..16" DRAWER TAN with SLIDES and STD Dividers	2
4	8145-01-473-1283	1NSG3	15520001-002	..BULK DRAWER TAN with SLIDES and NET	1
5	NOT ASSIGNED	1NSG3	15522023	...BULK DRAWER NET	1
END OF FIGURE 04					

STANDARD MODULES CLASS 1

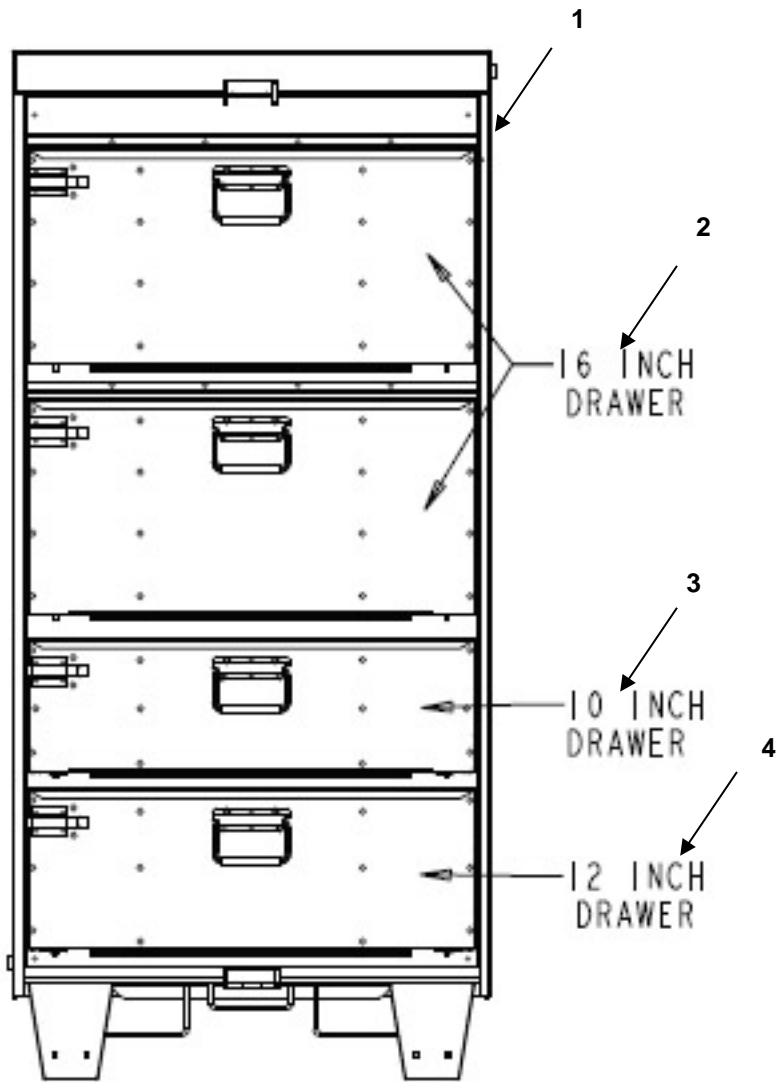

FIGURE 05 STANDARD MODULE #26 CLASS 1
COVER AND RETAINING BAR REMOVED FOR CLARITY

(1) ITEM NO.	(2) NSN	(3) CAGEC	(4) PART NUMBER	(5) DESCRIPTION AND USABLE ON CODE (UOC)	(6) QTY
				GROUP 0101 FIGURE 05 STANDARD Class 1 MODULE #26	
1	8145-01-501-0900	1NSG3	15700026-001	.MODULE #26 GREEN	1
2	8145-01-473-1527	1NSG3	15500016-001	..16" DRAWER GREEN with SLIDES and STD Dividers	2
3	8145-01-473-1351	1NSG3	15521000-001	..10" DRAWER GREEN with SLIDES and STD Dividers	1
4	8145-01-473-1275	1NSG3	15521200-001	..12" DRAWER GREEN with SLIDES and STD Dividers	1
1	8145-01-501-0900	1NSG3	15700026-002	.MODULE #26 TAN	1
2	8145-01-473-1527	1NSG3	15700016-002	..16" DRAWER TAN with SLIDES and STD Dividers	2
3	8145-01-473-1351	1NSG3	15521000-002	..10" DRAWER TAN with SLIDES and STD Dividers	1
4	8145-01-473-1275	1NSG3	15521200-002	..12" DRAWER GREEN with SLIDES and STD Dividers	1
END OF FIGURE 05					

STANDARD MODULES CLASS 2

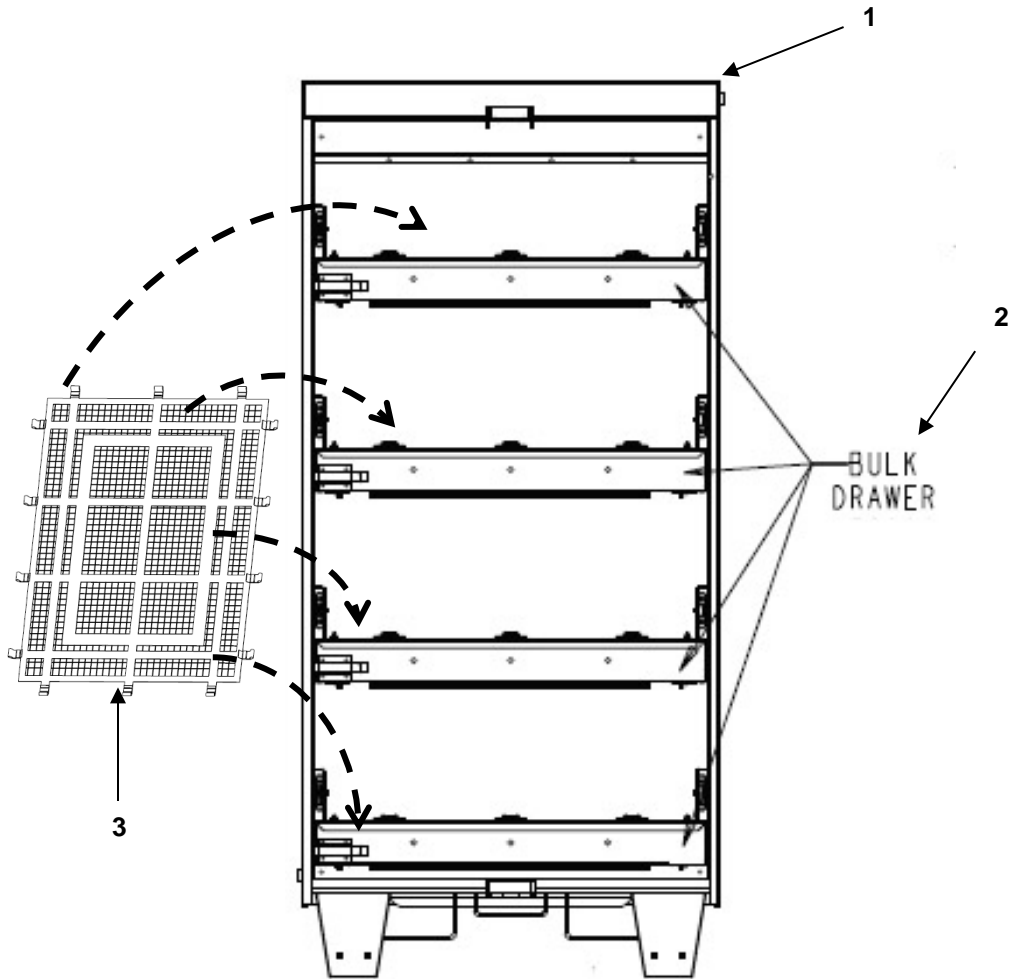

FIGURE 06 STANDARD MODULE #25 CLASS 2
COVER AND RETAINING BAR REMOVED FOR CLARITY

(1) ITEM NO.	(2) NSN	(3) CAGEC	(4) PART NUMBER	(5) DESCRIPTION AND USABLE ON CODE (UOC)	(6) QTY
				GROUP 0102 FIGURE 06 STANDARD Class 2 MODULE #25	
1	8145-01-501-0896	1NSG3	15700025-001	.MODULE #25 GREEN	1
2	8145-01-473-1283	1NSG3	15520001-001	..BULK DRAWER GREEN with SLIDES and NET	4
3	NOT ASSIGNED	1NSG3	15522023	...BULK DRAWER NET	4
1	8145-01-501-0896	1NSG3	15700025-002	.MODULE #25 TAN	1
2	8145-01-473-1283	1NSG3	15520001-002	..BULK DRAWER TAN with SLIDES and NET	4
3	NOT ASSIGNED	1NSG3	15522023	...BULK DRAWER NET	4
END OF FIGURE 06					

STANDARD MODULES CLASS 2

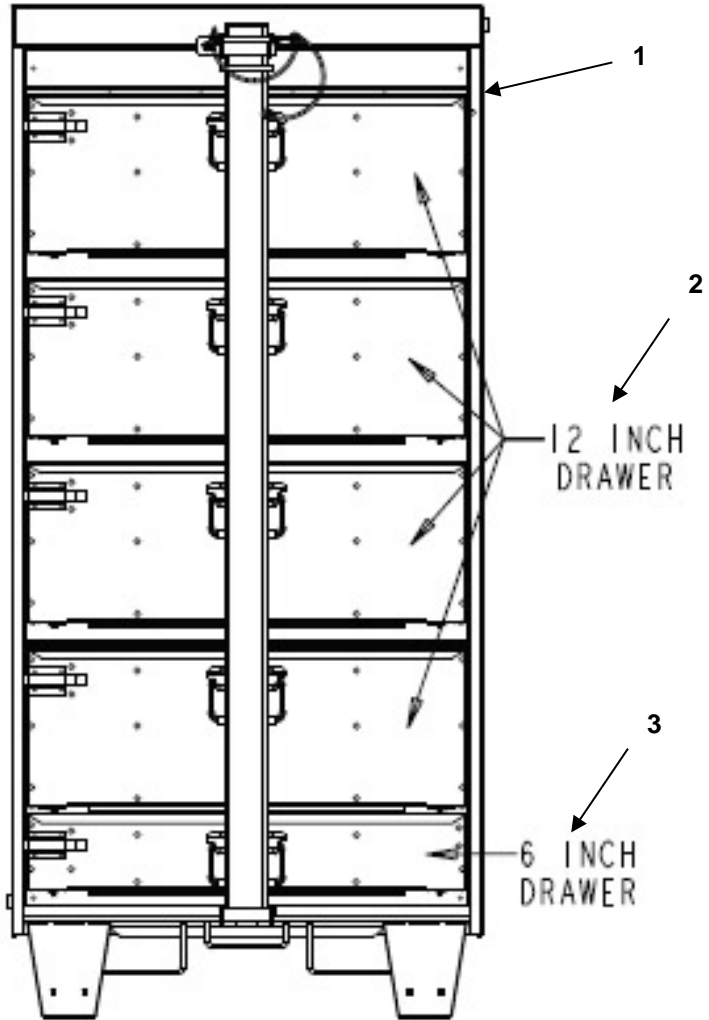

FIGURE 07 STANDARD MODULE #24 CLASS 2
COVER AND RETAINING BAR REMOVED FOR CLARITY

(1) ITEM NO.	(2) NSN	(3) CAGEC	(4) PART NUMBER	(5) DESCRIPTION AND USABLE ON CODE (UOC)	(6) QTY
				GROUP 0102 FIGURE 07 STANDARD Class 2 MODULE #24	
1	8145-01-501-0892	1NSG3	15700024-001	.MODULE #24 GREEN	1
2	8145-01-473-1275	1NSG3	15521200-001	..12" DRAWER GREEN with SLIDES and STD Dividers	4
3	8145-01-473-1319	1NSG3	15520600-001	..6" DRAWER GREEN with SLIDES and STD Dividers	1
1	8145-01-501-0892	1NSG3	15700024-002	.MODULE #24 TAN	1
2	8145-01-473-1275	1NSG3	15521200-002	..12" DRAWER TAN with SLIDES and STD Dividers	4
3	8145-01-473-1319	1NSG3	15520600-002	..6" DRAWER TAN with SLIDES and STD Dividers	1
END OF FIGURE 07					

STANDARD MODULES CLASS 2

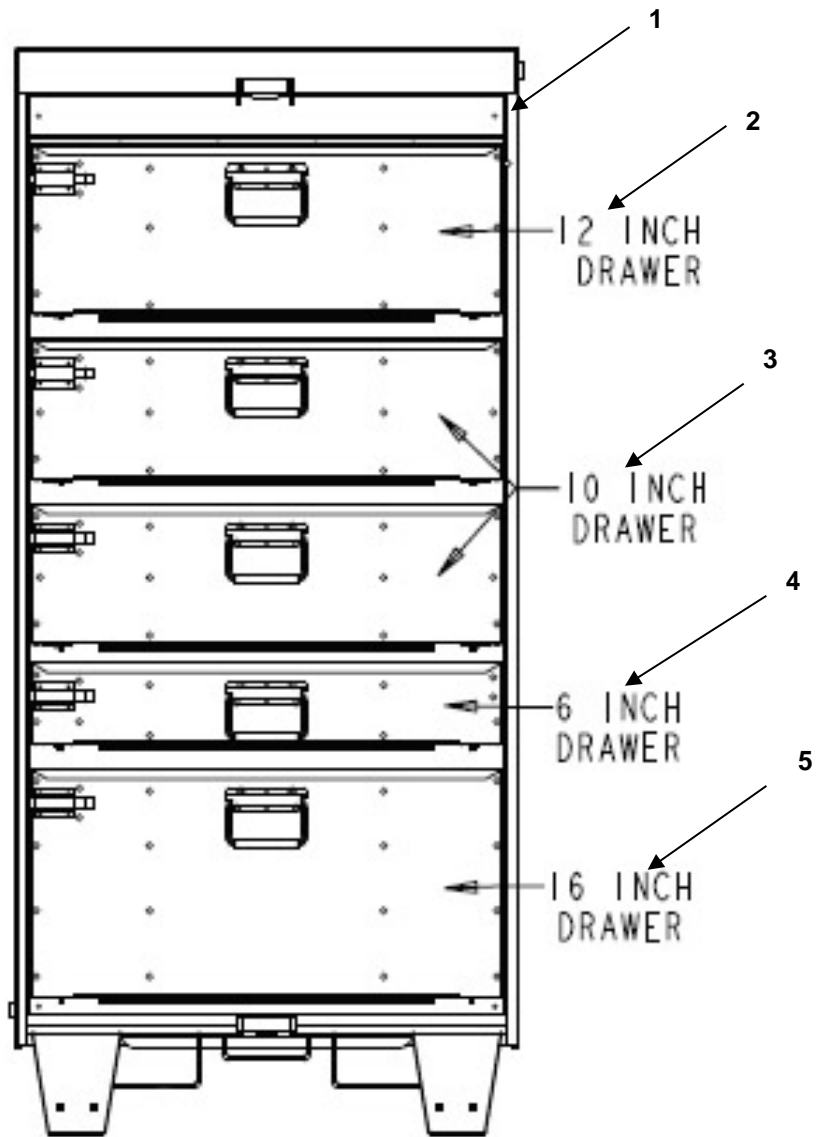

FIGURE 08 STANDARD MODULE #23 CLASS 2
COVER AND RETAINING BAR REMOVED FOR CLARITY

(1) ITEM NO.	(2) NSN	(3) CAGE C	(4) PART NUMBER	(5) DESCRIPTION AND USABLE ON CODE (UOC)	(6) QTY
				GROUP 0102 FIGURE 08 STANDARD Class 2 MODULE #23	
1	8145-01-523-4011	1NSG3	15700023-001	.MODULE #23 GREEN	1
2	8145-01-473-1275	1NSG3	15521200-001	..12" DRAWER GREEN with SLIDES and STD Dividers	1
3	8145-01-473-1351	1NSG3	15521000-001	..10" DRAWER GREEN with SLIDES and STD Dividers	2
4	8145-01-473-1319	1NSG3	15520600-001	..6" DRAWER GREEN with SLIDES and STD Dividers	1
5	8145-01-473-1527	1NSG3	15700016-001	..16" DRAWER GREEN with SLIDES and STD Dividers	1
1	8145-01-523-4011	1NSG3	15700023-002	.MODULE #23 TAN	1
2	8145-01-473-1275	1NSG3	15521200-002	..12" DRAWER TAN with SLIDES and STD Dividers	1
3	8145-01-473-1351	1NSG3	15521000-002	..10" DRAWER TAN with SLIDES and STD Dividers	2
4	8145-01-473-1319	1NSG3	15520600-002	..6" DRAWER TAN with SLIDES and STD Dividers	1
5	8145-01-473-1527	1NSG3	15700016-002	..16" DRAWER TAN with SLIDES and STD Dividers	1
END OF FIGURE 08					

STANDARD MODULES CLASS 2

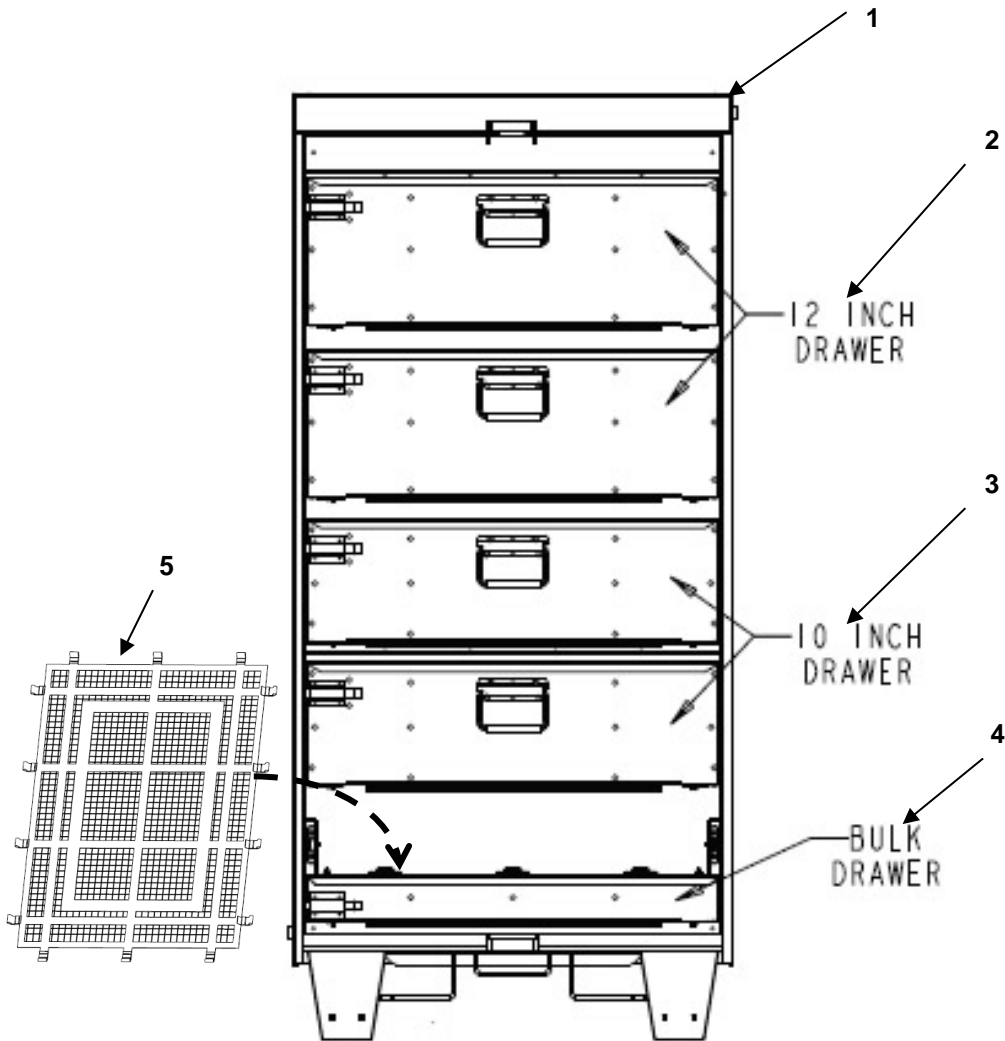

FIGURE 09 STANDARD MODULE #5 CLASS 2
COVER AND RETAINING BAR REMOVED FOR CLARITY

(1) ITEM NO.	(2) NSN	(3) CAGEC	(4) PART NUMBER	(5) DESCRIPTION AND USABLE ON CODE (UOC)	(6) QT Y
				GROUP 0102 FIGURE 09 STANDARD Class 2 MODULE #5	
1	8145-01-523-4005	1NSG3	15700005-001	.MODULE #5 GREEN	1
2	8145-01-473-1275	1NSG3	15521200-001	..12" DRAWER GREEN with SLIDES and STD Dividers	2
3	8145-01-473-1351	1NSG3	15521000-001	..10" DRAWER GREEN with SLIDES and STD Dividers	2
4	8145-01-473-1283	1NSG3	15520001-001	..BULK DRAWER GREEN with SLIDES and NET	1
5	NOT ASSIGNED	1NSG3	15522023	...BULK DRAWER NET	1
1	8145-01-523-4005	1NSG3	15700005-002	.MODULE #5 TAN	1
2	8145-01-473-1275	1NSG3	15521200-002	..12" DRAWER TAN with SLIDES and STD Dividers	2
3	8145-01-473-1351	1NSG3	15521000-002	..10" DRAWER TAN with SLIDES and STD Dividers	2
4	8145-01-473-1283	1NSG3	15520001-002	..BULK DRAWER TAN with SLIDES and NET	1
5	NOT ASSIGNED	1NSG3	15522023	...BULK DRAWER NET	1
END OF FIGURE 09					

STANDARD MODULES CLASS 2

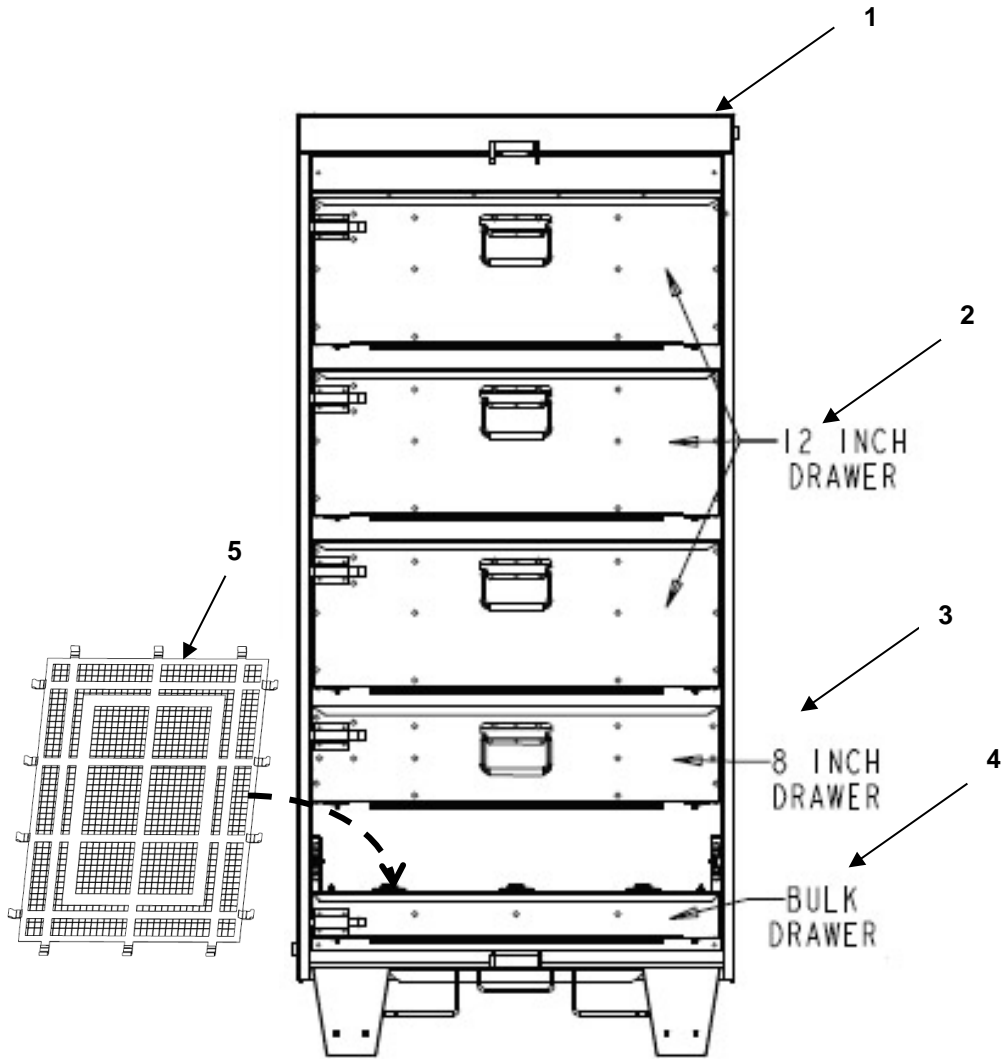

FIGURE 10 STANDARD MODULE #7 CLASS 2
COVER AND RETAINING BAR REMOVED FOR CLARITY

(1) ITEM NO.	(2) NSN	(3) CAGEC	(4) PART NUMBER	(5) DESCRIPTION AND USABLE ON CODE (UOC)	(6) QTY
				GROUP 0102 FIGURE 10 STANDARD Class 2 MODULE #7	
1	8145-01-501-0865	1NSG3	15700007-001	..MODULE #7 GREEN	1
2	8145-01-473-1275	1NSG3	15521200-001	..12" DRAWER GREEN with SLIDES and STD Dividers	3
3	8145-01-473-1226	1NSG3	15520800-001	..8" DRAWER GREEN with STD SLIDES and Dividers	1
4	8145-01-473-1283	1NSG3	15520001-001	..BULK DRAWER GREEN with SLIDES and NET	1
5	NOT ASSIGNED	1NSG3	15522023	...BULK DRAWER NET	1
1	8145-01-501-0865	1NSG3	15700007-002	MODULE #7 TAN	1
2	8145-01-473-1275	1NSG3	15521200-002	..12" DRAWER TAN with SLIDES and STD Dividers	3
3	8145-01-473-1226	1NSG3	15520800-002	..8" DRAWER TAN with STD SLIDES and Dividers	1
4	8145-01-473-1283	1NSG3	15520001-002	..BULK DRAWER TAN with SLIDES and NET	1
5	NOT ASSIGNED	1NSG3	15522023	..BULK DRAWER NET	1
END OF FIGURE 10					

STANDARD MODULES CLASS 3

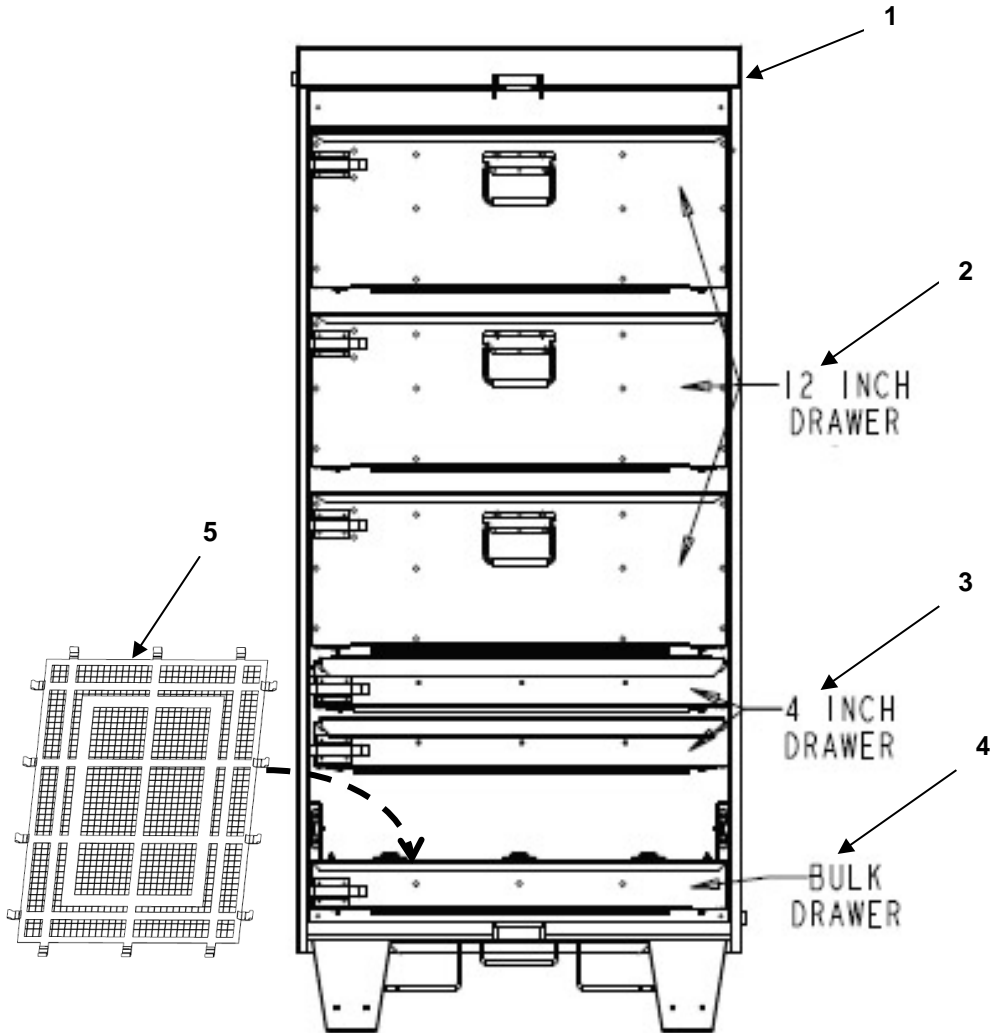

FIGURE 11 STANDARD MODULE #3 CLASS 3
COVER AND RETAINING BAR REMOVED FOR CLARITY

(1) ITEM NO.	(2) NSN	(3) CAGEC	(4) PART NUMBER	(5) DESCRIPTION AND USABLE ON CODE (UOC)	(6) QTY
				GROUP 0103 FIGURE 11 STANDARD CLASS 3 MODULES #3	
1	8145-01-523-4014	1NSG3	15700003-001	.MODULE #3 GREEN	1
2	8145-01-473-1275	1NSG3	15521200-001	..12" DRAWER GREEN with SLIDES and STD Dividers	3
3	8145-01-473-1218	1NSG3	15520400-001	..4" DRAWER GREEN with SLIDES and STD Dividers	2
4	8145-01-473-1283	1NSG3	15520001-001	..BULK DRAWER GREEN with SLIDES and NET	1
5	NOT ASSIGNED	1NSG3	15522023	...BULK DRAWER NET	1
1	8145-01-523-4014	1NSG3	15700003-002	MODULE #3 TAN	1
2	8145-01-473-1275	1NSG3	15521200-002	..12" DRAWER TAN with SLIDES and STD Dividers	3
3	8145-01-473-1218	1NSG3	15520400-002	..4" DRAWER TAN with SLIDES and STD Dividers	2
4	8145-01-473-1283	1NSG3	15520001-002	..BULK DRAWER TAN with SLIDES and NET	1
5	NOT ASSIGNED	1NSG3	15522023	...BULK DRAWER NET	1
END OF FIGURE 11					

STANDARD MODULES CLASS 3

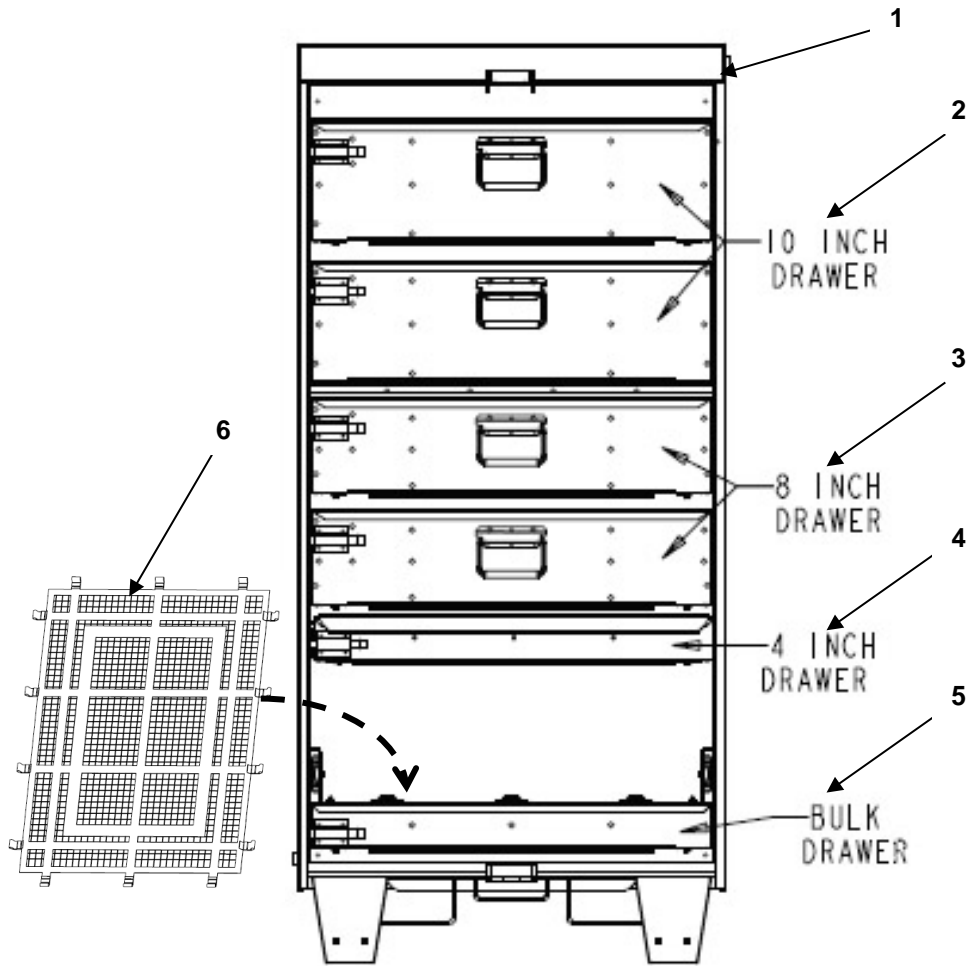

FIGURE 12 STANDARD MODULE #14 CLASS 3
COVER AND RETAINING BAR REMOVED FOR CLARITY

(1) ITEM NO.	(2) NSN	(3) CAGEC	(4) PART NUMBER	(5) DESCRIPTION AND USABLE ON CODE (UOC)	(6) QTY
				GROUP 0103 FIGURE 12 STANDARD CLASS 3 MODULES #14	
1	8145-01-501-0869	1NSG3	15700014-001	..MODULE #14 GREEN	1
2	8145-01-473-1351	1NSG3	15521000-001	..10" DRAWER GREEN with SLIDES and STD Dividers	2
3	8145-01-473-1226	1NSG3	15520800-001	..8" DRAWER GREEN with STD SLIDES and Dividers	2
4	8145-01-473-1218	1NSG3	15520400-001	..4" DRAWER GREEN with SLIDES and STD Dividers	1
5	8145-01-473-1283	1NSG3	15520001-001	..BULK DRAWER GREEN with SLIDES and NET	1
6	NOT ASSIGNED	1NSG3	15522023	...BULK DRAWER NET	1
1	8145-01-501-0869	1NSG3	15700014-002	..MODULE #14 TAN	1
2	8145-01-473-1351	1NSG3	15521000-002	..10" DRAWER TAN with SLIDES and STD Dividers	2
3	8145-01-473-1226	1NSG3	15520800-002	..8" DRAWER TAN with STD SLIDES and Dividers	2
4	8145-01-473-1218	1NSG3	15520400-002	..4" DRAWER TAN with SLIDES and STD Dividers	1
5	8145-01-473-1283	1NSG3	15520001-002	..BULK DRAWER TAN with SLIDES and NET	1
6	NOT ASSIGNED	1NSG3	15522023	...BULK DRAWER NET	1
END OF FIGURE 12					

STANDARD MODULES CLASS 3

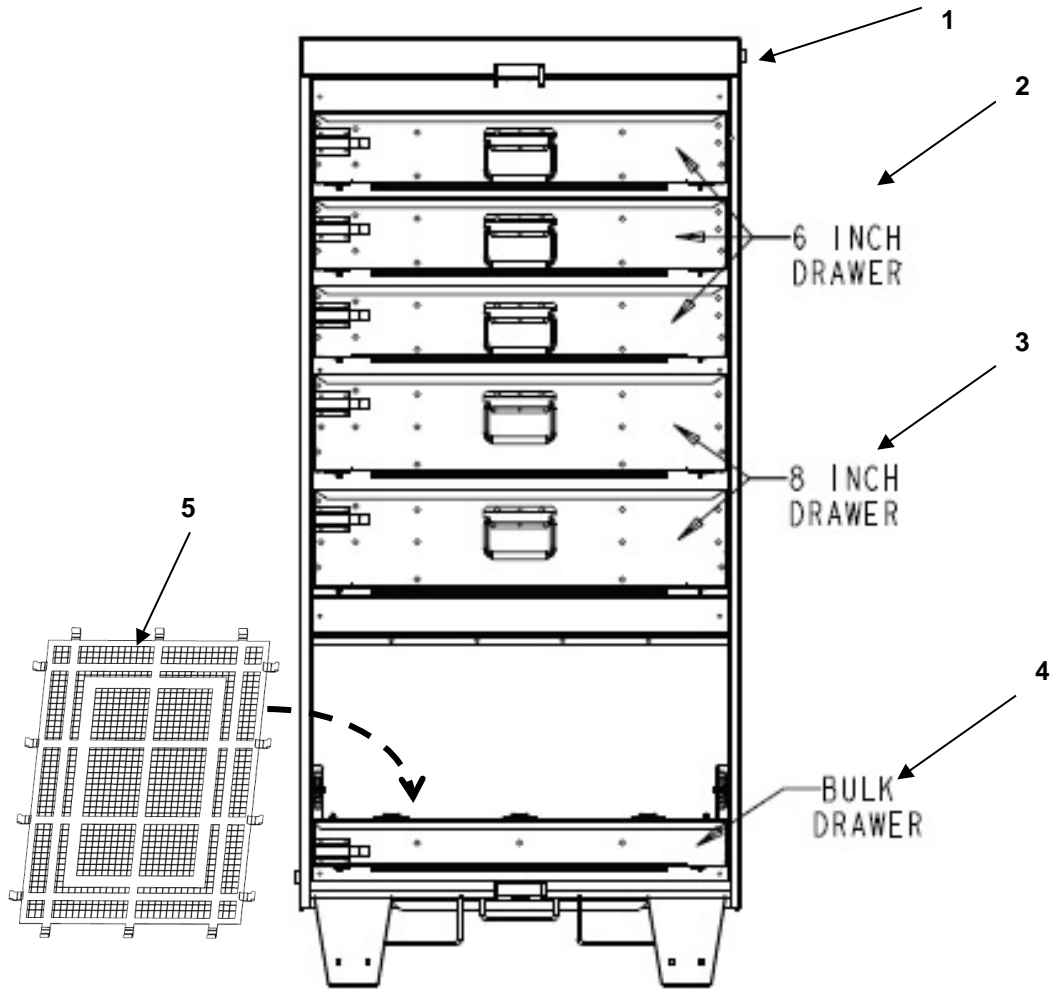

FIGURE 13 STANDARD MODULE #19 CLASS 3
COVER AND RETAINING BAR REMOVED FOR CLARITY

(1) ITEM NO.	(2) NSN	(3) CAGEC	(4) PART NUMBER	(5) DESCRIPTION AND USABLE ON CODE (UOC)	(6) QTY
				GROUP 0103 FIGURE 13 STANDARD CLASS 3 MODULES #19	
1	8145-01-523-4022	1NSG3	15700019-001	.MODULE #19 GREEN	1
2	8145-01-473-1319	1NSG3	15520600-001	..6" DRAWER GREEN with SLIDES and STD Dividers	3
3	8145-01-473-1226	1NSG3	15520800-001	..8" DRAWER GREEN with STD SLIDES and Dividers	2
4	8145-01-473-1283	1NSG3	15520001-001	..BULK DRAWER GREEN with SLIDES and NET	1
5	NOT ASSIGNED	1NSG3	15522023	...BULK DRAWER NET	1
1	8145-01-523-4022	1NSG3	15700019-002	.MODULE #19 TAN	1
2	8145-01-473-1319	1NSG3	15520600-002	..6" DRAWER TAN with SLIDES and STD Dividers	3
3	8145-01-473-1226	1NSG3	15520800-002	..8" DRAWER TAN with STD SLIDES and Dividers	2
4	8145-01-473-1283	1NSG3	15520001-002	..BULK DRAWER TAN with SLIDES and NET	1
5	NOT ASSIGNED	1NSG3	15522023	...BULK DRAWER NET	1
END OF FIGURE 13					

STANDARD MODULES CLASS 3

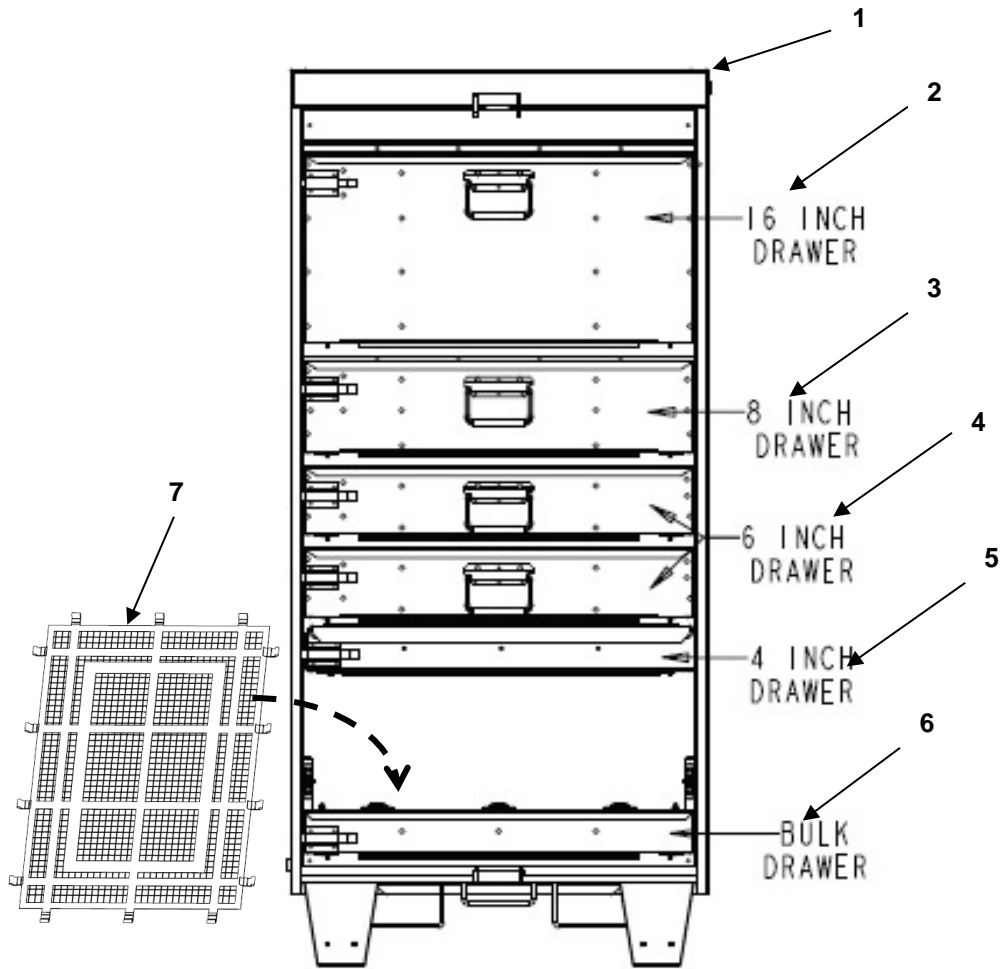

FIGURE 14 STANDARD MODULE #16 CLASS 3
COVER AND RETAINING BAR REMOVED FOR CLARITY

(1) ITEM NO.	(2) NSN	(3) CAGEC	(4) PART NUMBER	(5) DESCRIPTION AND USABLE ON CODE (UOC)	(6) QTY
				GROUP 0103 FIGURE 14 STANDARD CLASS 3 MODULES #16	
1	8145-01-523-4028	1NSG3	15700016-001	.MODULE #16 GREEN	1
2	8145-01-473-1527	1NSG3	15700016-001	..16" DRAWER GREEN with SLIDES and STD Dividers	1
3	8145-01-473-1226	1NSG3	15520800-001	..8" DRAWER GREEN with STD SLIDES and Dividers	1
4	8145-01-473-1319	1NSG3	15520600-001	..6" DRAWER GREEN with SLIDES and STD Dividers	2
5	8145-01-473-1218	1NSG3	15520400-001	..4" DRAWER GREEN with SLIDES and STD Dividers	1
6	8145-01-473-1283	1NSG3	15520001-001	..BULK DRAWER GREEN with SLIDES and NET	1
7	NOT ASSIGNED	1NSG3	15522023	...BULK DRAWER NET	1
1	8145-01-523-4028	1NSG3	15700016-002	.MODULE #16 TAN	1
2	8145-01-473-1527	1NSG3	15700016-002	..16" DRAWER TAN with SLIDES and STD Dividers	1
3	8145-01-473-1226	1NSG3	15520800-002	..8" DRAWER TAN with STD SLIDES and Dividers	1
4	8145-01-473-1319	1NSG3	15520600-002	..6" DRAWER TAN with SLIDES and STD Dividers	2
5	8145-01-473-1218	1NSG3	15520400-002	..4" DRAWER TAN with SLIDES and STD Dividers	1
6	8145-01-473-1283	1NSG3	15520001-002	..BULK DRAWER TAN with SLIDES and NET	1
7	NOT ASSIGNED	1NSG3	15522023	...BULK DRAWER NET	1
END OF FIGURE 14					

STANDARD MODULES CLASS 4

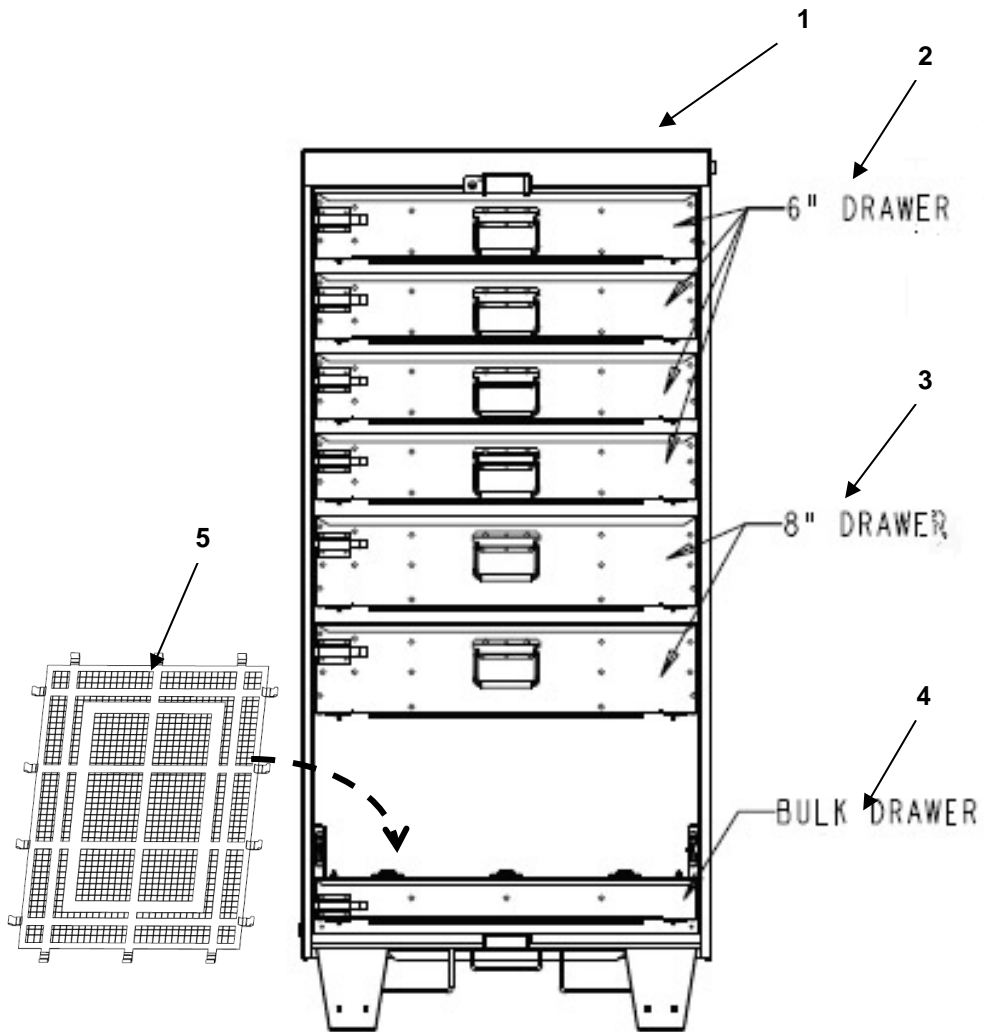

FIGURE 15 STANDARD MODULE #18 CLASS 4
COVER AND RETAINING BAR REMOVED FOR CLARITY

(1) ITEM NO.	(2) NSN	(3) CAGEC	(4) PART NUMBER	(5) DESCRIPTION AND USABLE ON CODE (UOC)	(6) QTY
				GROUP 0104 FIGURE 15 STANDARD CLASS 4 MODULES #18	
1	8145-01-523-4025	1NSG3	15700018-001	.MODULE #18 GREEN	1
2	8145-01-473-1319	1NSG3	15520600-001	..6" DRAWER GREEN with SLIDES and STD Dividers	4
3	8145-01-473-1226	1NSG3	15520800-001	..8" DRAWER GREEN with STD SLIDES and Dividers	2
4	8145-01-473-1283	1NSG3	15520001-001	..BULK DRAWER GREEN with SLIDES and NET	1
5	NOT ASSIGNED	1NSG3	15522023	...BULK DRAWER NET	1
1	8145-01-523-4025	1NSG3	15700018-002	MODULE #18 TAN	1
2	8145-01-473-1319	1NSG3	15520600-002	..6" DRAWER TAN with SLIDES and STD Dividers	4
3	8145-01-473-1226	1NSG3	15520800-002	..8" DRAWER TAN with STD SLIDES and Dividers	2
4	8145-01-473-1283	1NSG3	15520001-002	..BULK DRAWER TAN with SLIDES and NET	1
5	NOT ASSIGNED	1NSG3	15522023	...BULK DRAWER NET	1
END OF FIGURE 15					

STANDARD MODULES CLASS 5

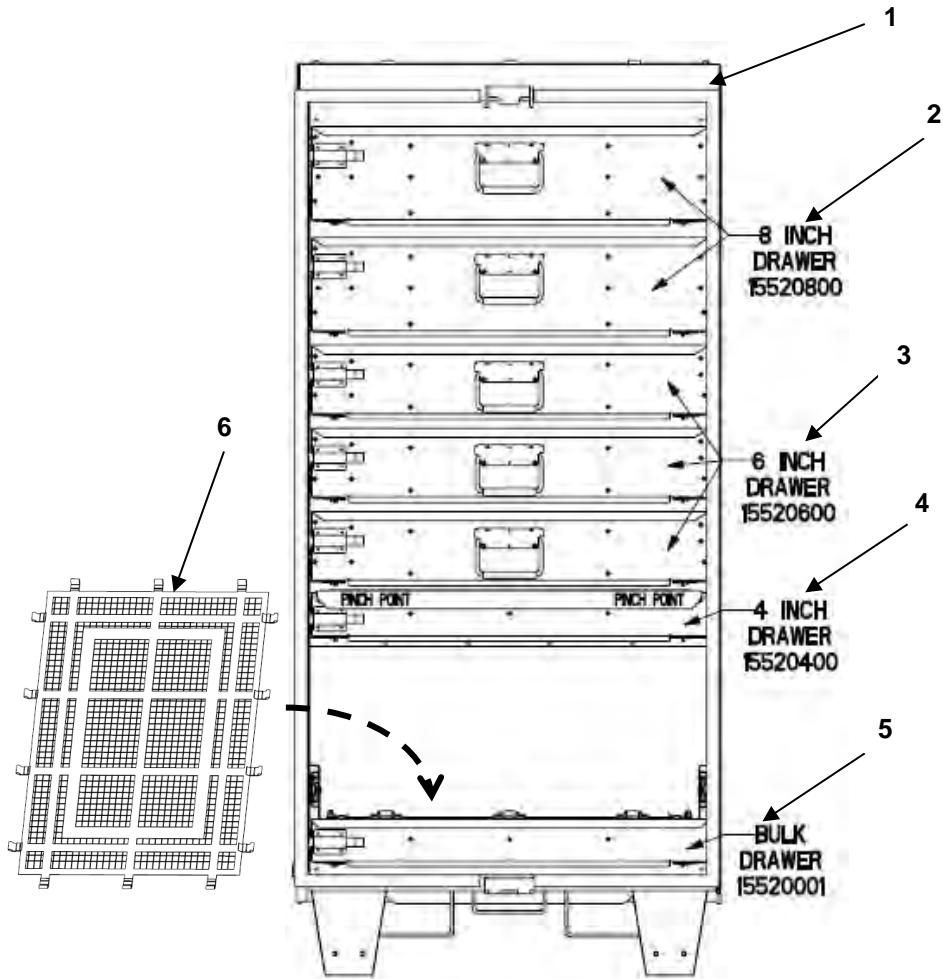

FIGURE 16 STANDARD MODULE #20 CLASS 5
COVER AND RETAINING BAR REMOVED FOR CLARITY

(1) ITEM NO.	(2) NSN	(3) CAGEC	(4) PART NUMBER	(5) DESCRIPTION AND USABLE ON CODE (UOC)	(6) QTY
				GROUP 0105 FIGURE 16 STANDARD CLASS 5 MODULES #20	
1	8145-01-523-4039	1NSG3	15700020-001	.MODULE #20 GREEN	1
2	8145-01-473-1226	1NSG3	15520800-001	..8" DRAWER GREEN with STD SLIDES and Dividers	2
3	8145-01-473-1319	1NSG3	15520600-001	..6" DRAWER GREEN with SLIDES and STD Dividers	3
4	8145-01-473-1218	1NSG3	15520400-001	..4" DRAWER GREEN with SLIDES and STD Dividers	1
5	8145-01-473-1283	1NSG3	15520001-001	..BULK DRAWER GREEN with SLIDES and NET	1
6	NOT ASSIGNED	1NSG3	15522023	..BULK DRAWER NET	1
1	8145-01-523-4039	1NSG3	15700020-002	.MODULE #20 TAN	1
2	8145-01-473-1226	1NSG3	15520800-002	..8" DRAWER TAN with STD SLIDES and Dividers	2
3	8145-01-473-1319	1NSG3	15520600-002	..6" DRAWER TAN with SLIDES and STD Dividers	3
4	8145-01-473-1218	1NSG3	15520400-002	..4" DRAWER TAN with SLIDES and STD Dividers	1
5	8145-01-473-1283	1NSG3	15520001-002	..BULK DRAWER TAN with SLIDES and NET	1
6	NOT ASSIGNED	1NSG3	15522023	...BULK DRAWER NET	1
END OF FIGURE 16					

STANDARD MODULES CLASS 5

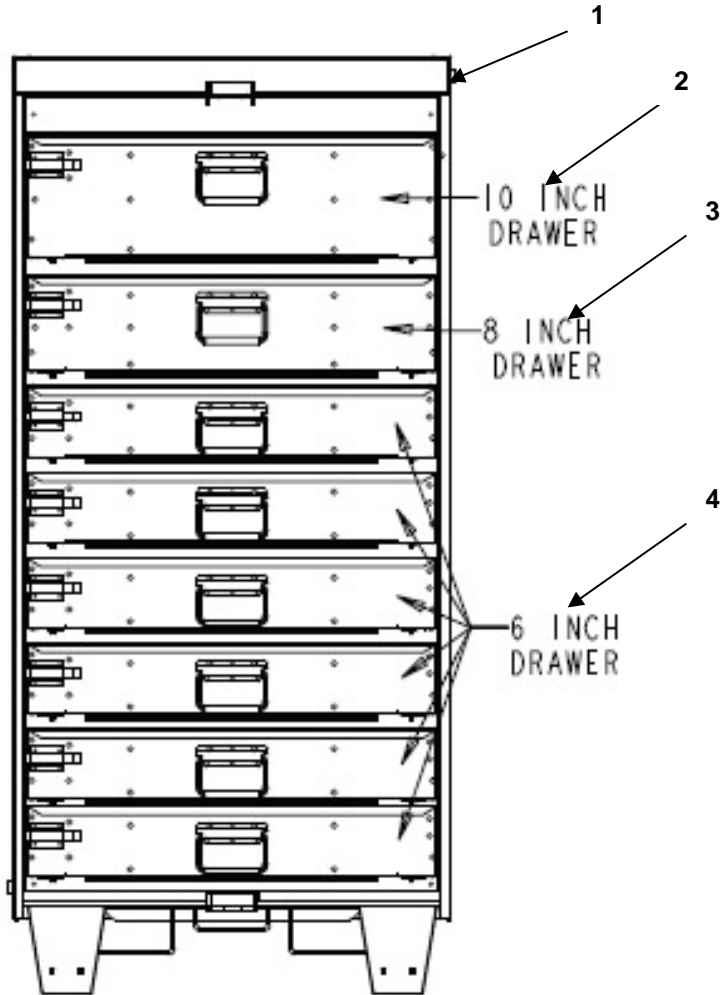

FIGURE 17 STANDARD MODULE #22 CLASS 5
COVER AND RETAINING BAR REMOVED FOR CLARITY

(1) ITEM NO.	(2) NSN	(3) CAGEC	(4) PART NUMBER	(5) DESCRIPTION AND USABLE ON CODE (UOC)	(6) QTY
				GROUP 0105 FIGURE 17 STANDARD CLASS 5 MODULES #22	
1	8145-01-523-4040	1NSG3	15700022-001	.MODULE #22 GREEN	1
2	8145-01-473-1351	1NSG3	15521000-001	..10" DRAWER GREEN with SLIDES and STD Dividers	1
3	8145-01-473-1226	1NSG3	15520800-001	..8" DRAWER GREEN with STD SLIDES and Dividers	1
4	8145-01-473-1319	1NSG3	15520600-001	..6" DRAWER GREEN with SLIDES and STD Dividers	6
1	8145-01-523-4040	1NSG3	15700022-002	.MODULE #22 TAN	1
2	8145-01-473-1351	1NSG3	15521000-002	..10" DRAWER TAN with SLIDES and STD Dividers	1
3	8145-01-473-1226	1NSG3	15520800-002	..8" DRAWER TAN with STD SLIDES and Dividers	1
4	8145-01-473-1319	1NSG3	15520600-002	..6" DRAWER TAN with SLIDES and STD Dividers	6
END OF FIGURE 17					

STANDARD MODULES CLASS 5

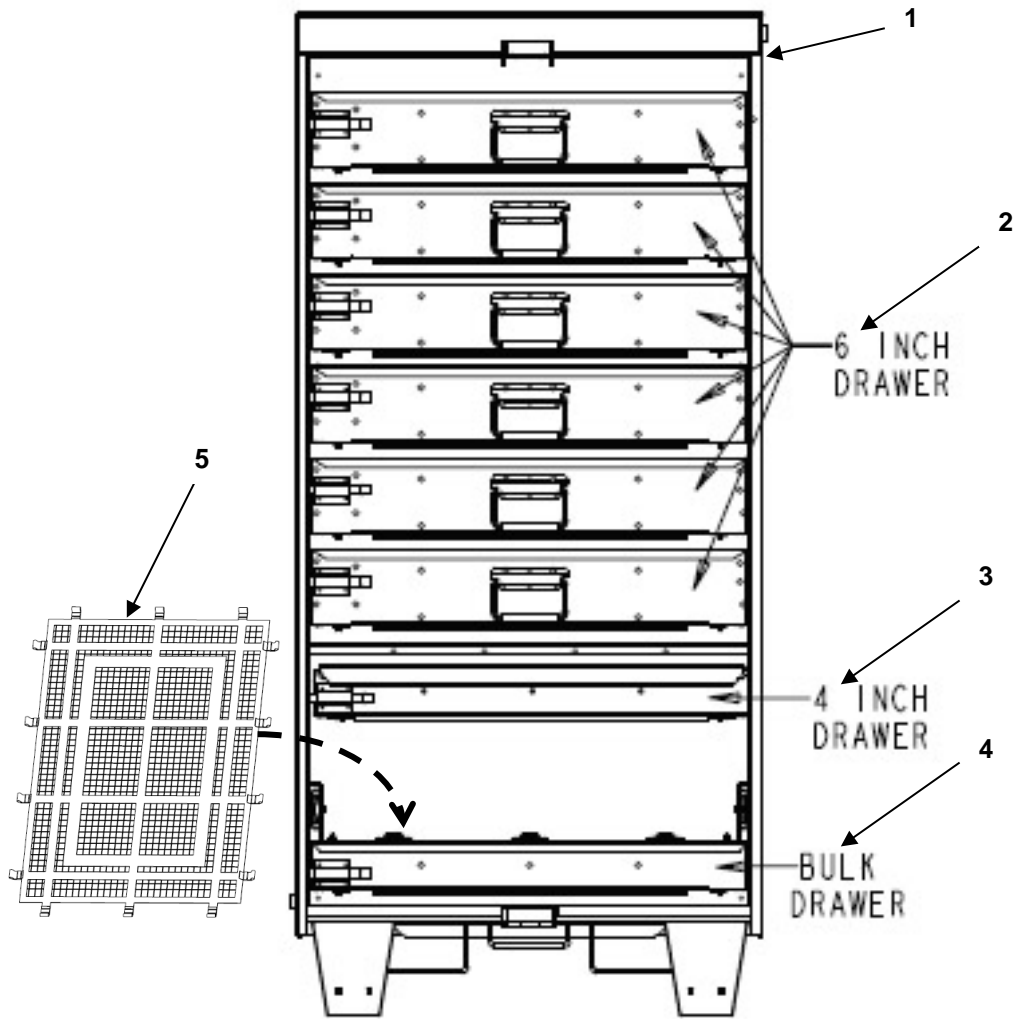

FIGURE 18 STANDARD MODULE #13 CLASS 5
COVER AND RETAINING BAR REMOVED FOR CLARITY

(1) ITEM NO.	(2) NSN	(3) CAGEC	(4) PART NUMBER	(5) DESCRIPTION AND USABLE ON CODE (UOC)	(6) QTY
				GROUP 0105 FIGURE 18 STANDARD CLASS 5 MODULES #13	
1	8145-01-501-0866	1NSG3	15700013-001	..MODULE #13 GREEN	1
2	8145-01-473-1319	1NSG3	15520600-001	..6" DRAWER GREEN with SLIDES and STD Dividers	6
3	8145-01-473-1218	1NSG3	15520400-001	..4" DRAWER GREEN with SLIDES and STD Dividers	1
4	8145-01-473-1283	1NSG3	15520001-001	..BULK DRAWER GREEN with SLIDES and NET	1
5	NOT ASSIGNED	1NSG3	15522023	...BULK DRAWER NET	1
1	8145-01-501-0866	1NSG3	15700013-002	MODULE #13 TAN	1
2	8145-01-473-1319	1NSG3	15520600-002	..6" DRAWER TAN with SLIDES and STD Dividers	6
3	8145-01-473-1218	1NSG3	15520400-002	..4" DRAWER TAN with SLIDES and STD Dividers	1
4	8145-01-473-1283	1NSG3	15520001-002	..BULK DRAWER TAN with SLIDES and NET	1
5	NOT ASSIGNED	1NSG3	15522023	...BULK DRAWER NET	1
END OF FIGURE 18					

STANDARD MODULES CLASS 5

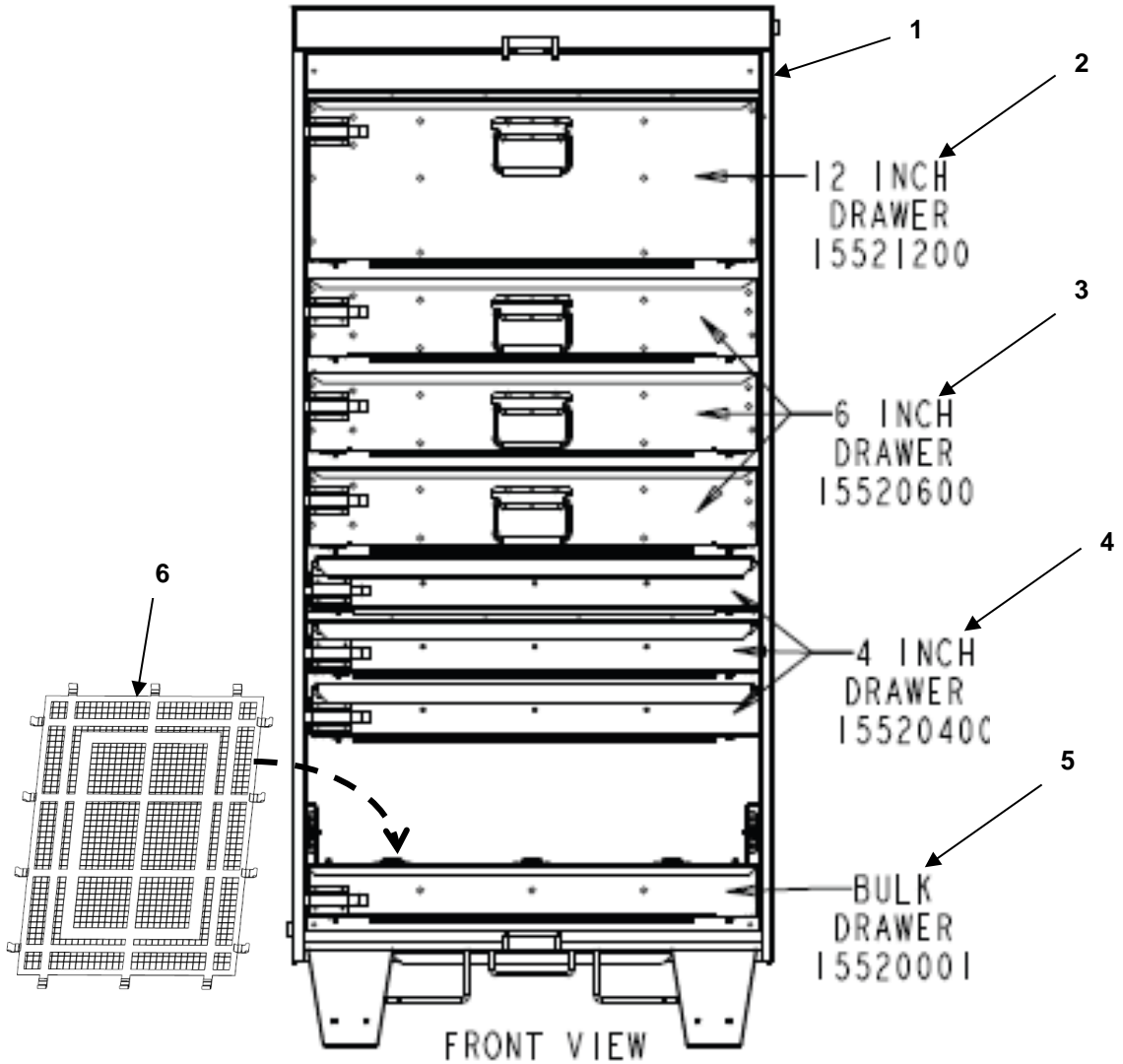

FIGURE 19 STANDARD MODULE #11 CLASS 5
COVER AND RETAINING BAR REMOVED FOR CLARITY

(1) ITEM NO.	(2) NSN	(3) CAGEC	(4) PART NUMBER	(5) DESCRIPTION AND USABLE ON CODE (UOC)	(6) QTY
				GROUP 0105 FIGURE 19 STANDARD CLASS 5 MODULES #11	
1	8145-01-522-0667	1NSG3	15700011-001	.MODULE #11 GREEN	1
2	8145-01-473-1275	1NSG3	15521200-001	..12" DRAWER GREEN with SLIDES and STD Dividers	1
3	8145-01-473-1319	1NSG3	15520600-001	..6" DRAWER GREEN with SLIDES and STD Dividers	3
4	8145-01-473-1218	1NSG3	15520400-001	..4" DRAWER GREEN with SLIDES and STD Dividers	3
5	8145-01-473-1283	1NSG3	15520001-001	..BULK DRAWER GREEN with SLIDES and NET	1
6	NOT ASSIGNED	1NSG3	15522023	...BULK DRAWER NET	1
1	8145-01-522-0667	1NSG3	15700011-002	.MODULE #11 TAN	1
2	8145-01-473-1275	1NSG3	15521200-002	..12" DRAWER TAN with SLIDES and STD Dividers	1
3	8145-01-473-1319	1NSG3	15520600-002	..6" DRAWER TAN with SLIDES and STD Dividers	3
4	8145-01-473-1218	1NSG3	15520400-002	..4" DRAWER TAN with SLIDES and STD Dividers	3
5	8145-01-473-1283	1NSG3	15520001-002	..BULK DRAWER TAN with SLIDES and NET	1
6	NOT ASSIGNED	1NSG3	15522023	...BULK DRAWER NET	1
END OF FIGURE 19					

STANDARD MODULES CLASS 6

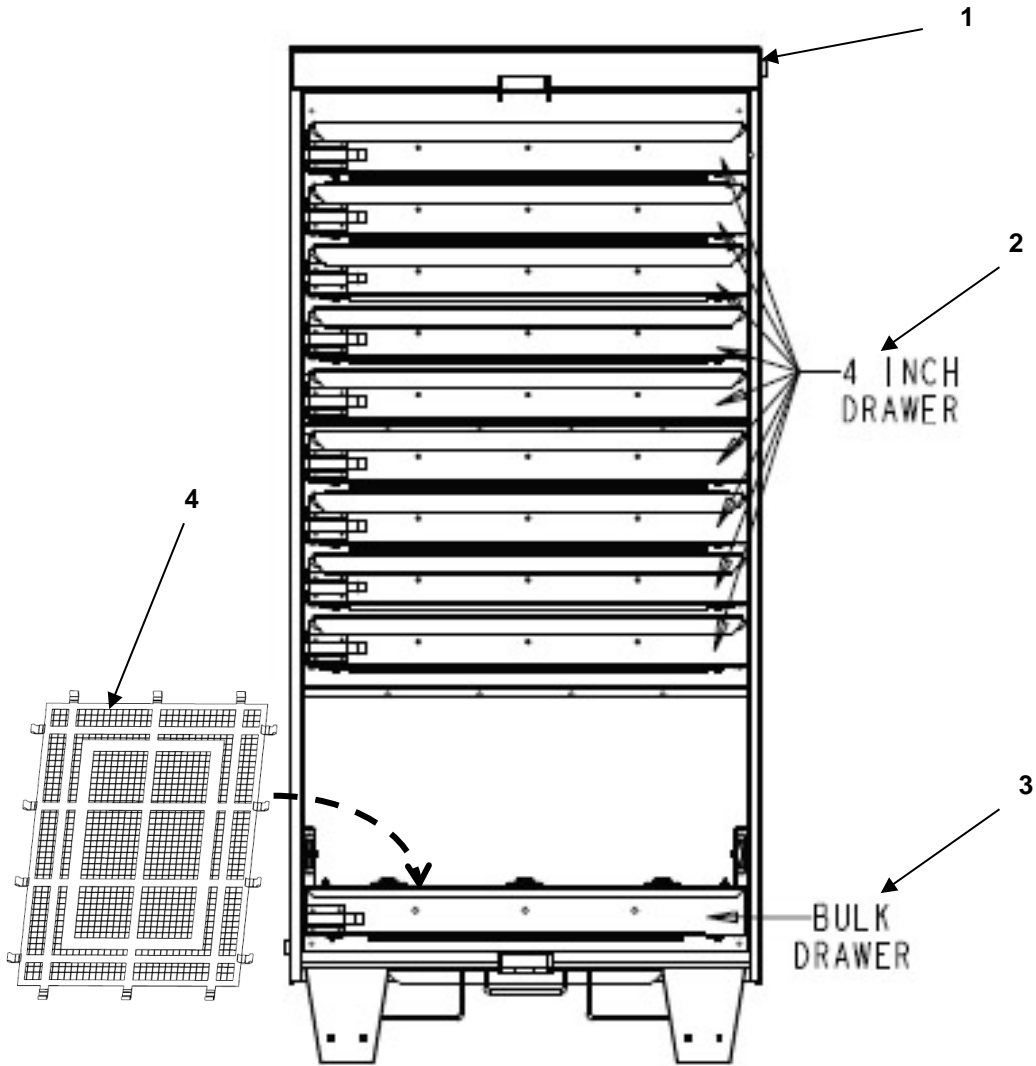

FIGURE 20 STANDARD MODULE #17 CLASS 6
COVER AND RETAINING BAR REMOVED FOR CLARITY

(1) ITEM NO.	(2) NSN	(3) CAGEC	(4) PART NUMBER	(5) DESCRIPTION AND USABLE ON CODE (UOC)	(6) QTY
				GROUP 0106 FIGURE 20 STANDARD CLASS 6 MODULES #17	
1	8145-01-502-2491	1NSG3	15700017-001	.MODULE #17 GREEN	1
2	8145-01-473-1218	1NSG3	15520400-001	..4" DRAWER GREEN with SLIDES and STD Dividers	9
3	8145-01-473-1283	1NSG3	15520001-001	..BULK DRAWER GREEN with SLIDES and NET	1
4	NOT ASSIGNED	1NSG3	15522023	...BULK DRAWER NET	1
1	8145-01-502-2491	1NSG3	15700017-002	MODULE #17 TAN	1
2	8145-01-473-1218	1NSG3	15520400-002	..4" DRAWER TAN with SLIDES and STD Dividers	9
3	8145-01-473-1283	1NSG3	15520001-002	..BULK DRAWER TAN with SLIDES and NET	1
4	NOT ASSIGNED	1NSG3	15522023	...BULK DRAWER NET	1
END OF FIGURE 20					

STANDARD MODULES CLASS 6

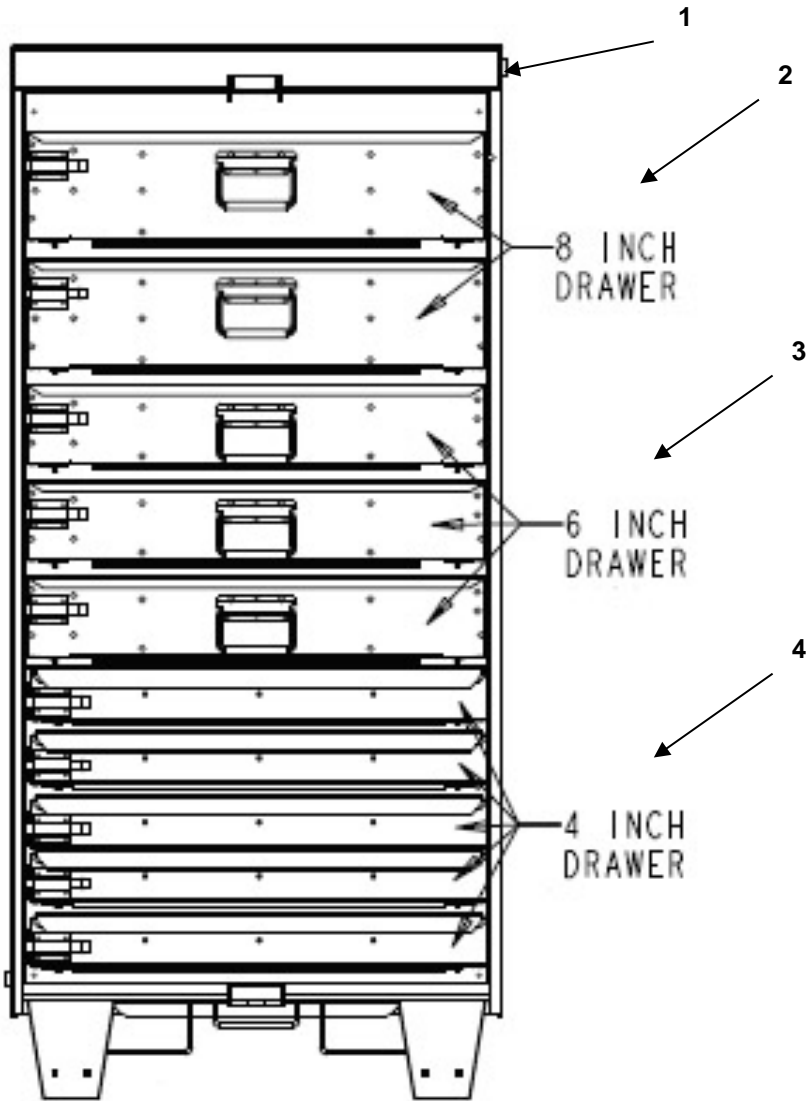

FIGURE 21 STANDARD MODULE #21 CLASS 6
COVER AND RETAINING BAR REMOVED FOR CLARITY

(1) ITEM NO.	(2) NSN	(3) CAGEC	(4) PART NUMBER	(5) DESCRIPTION AND USABLE ON CODE (UOC)	(6) QTY
				GROUP 0106 FIGURE 21 STANDARD CLASS 6 MODULES #21	
1	8145-01-502-2494	1NSG3	15700021-001	.MODULE #21 GREEN	1
2	8145-01-473-1226	1NSG3	15520800-001	..8" DRAWER GREEN with STD SLIDES and Dividers	2
3	8145-01-473-1319	1NSG3	15520600-001	..6" DRAWER GREEN with SLIDES and STD Dividers	3
4	8145-01-473-1218	1NSG3	15520400-001	..4" DRAWER GREEN with SLIDES and STD Dividers	5
1	8145-01-502-2494	1NSG3	15700021-002	.MODULE #21 TAN	1
2	8145-01-473-1226	1NSG3	15520800-002	..8" DRAWER TAN with STD SLIDES and Dividers	2
3	8145-01-473-1319	1NSG3	15520600-002	..6" DRAWER TAN with SLIDES and STD Dividers	3
4	8145-01-473-1218	1NSG3	15520400-002	..4" DRAWER TAN with SLIDES and STD Dividers	5
END OF FIGURE 21					

STANDARD MODULE DRAWERS 4" thru 8"

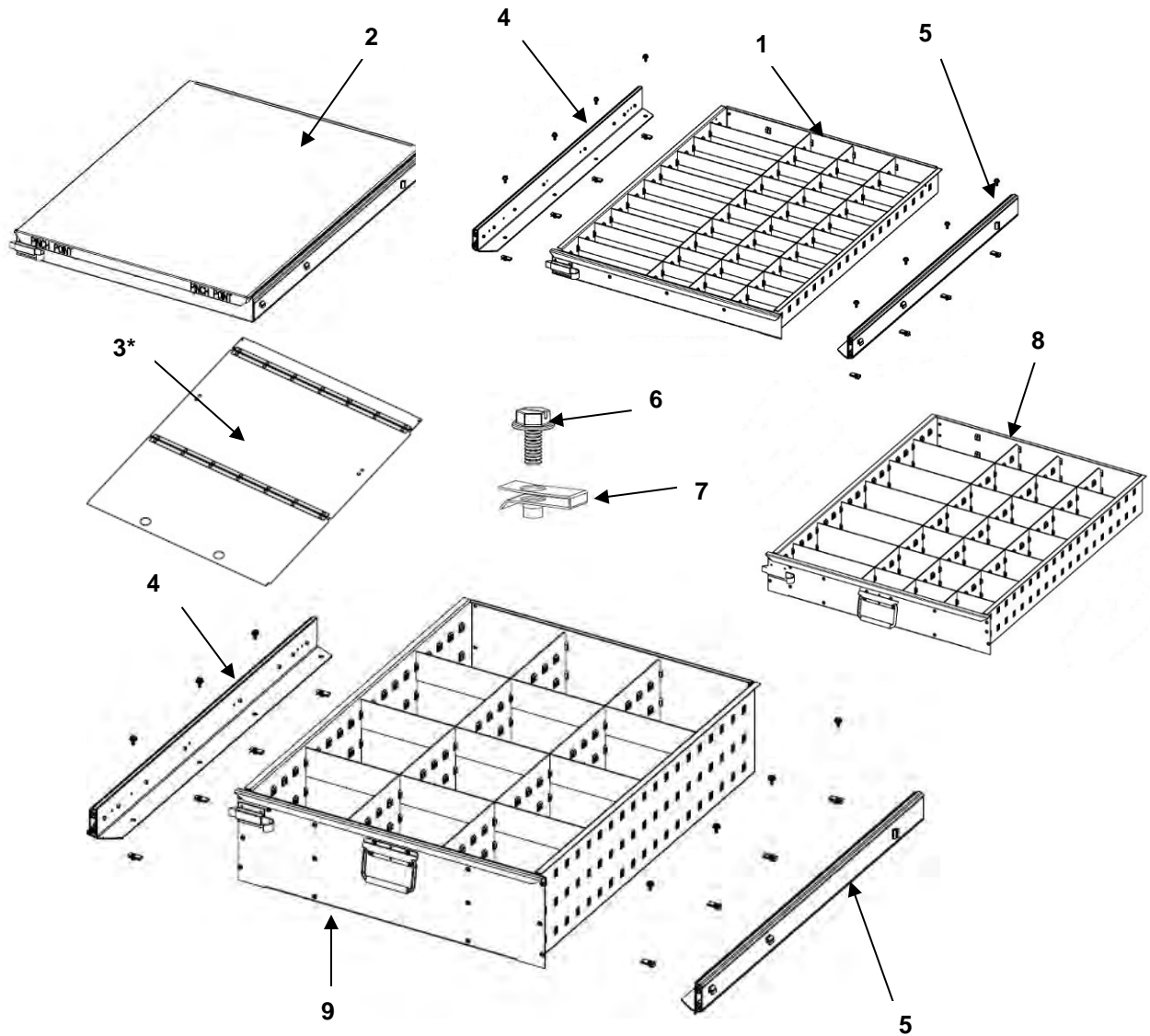

FIGURE 22 STANDARD MODULE DRAWERS 4" THRU 8"

NOTE

*Item #3 available on request

(1) ITEM NO.	(2) NSN	(3) CAGEC	(4) PART NUMBER	(5) DESCRIPTION AND USABLE ON CODE (UOC)	(6) QTY
				GROUP 0107 FIGURE 22 STANDARD MODULE DRAWERS 4" THRU 8"	
1	8145-01-473-1218	1NSG3	15520400-001	.4" DRAWER GREEN with SLIDES, STD Dividers and LID	1
1	8145-01-473-1218	1NSG3	15520400-002	.4" DRAWER TAN with SLIDE, STD Dividers and LID	1
2	NOT ASSIGNED	1NSG3	16502505	..4" DRAWER FLAT LID	1
3*	NOT ASSIGNED	1NSG3	16020424	..FOLDING STYLE LID 4" DRAWER *	1
4	NOT ASSIGNED	1NSG3	15981900	..SINGLE BEARING DRAWER SLIDE LEFT	1
5	NOT ASSIGNED	1NSG3	15981901	..SINGLE BEARING DRAWER SLIDE RIGHT	1
6	NOT ASSIGNED	1NSG3	15121054	...SCREW 1/4 -20 x 5/8" BH BL	8
7	NOT ASSIGNED	1NSG3	15121055	...THREADED CLIP	8
8	8145-01-473-1319	1NSG3	15520600-001	.6" DRAWER GREEN with SLIDES and STD Dividers	1
8	8145-01-473-1319	1NSG3	15520600-002	.6" DRAWER TAN with SLIDES and STD Dividers	1
4	NOT ASSIGNED	1NSG3	15981900	..SINGLE BEARING DRAWER SLIDE LEFT	1
5	NOT ASSIGNED	1NSG3	15981901	..SINGLE BEARING DRAWER SLIDE RIGHT	1
6	NOT ASSIGNED	1NSG3	15121054	...SCREW 1/4 -20 x 5/8" BH BL	8
7	NOT ASSIGNED	1NSG3	15121055	...THREADED CLIP	8
9	8145-01-473-1226	1NSG3	15520800-001	.8" DRAWER GREEN with SLIDES and STD Dividers	1
9	8145-01-473-1226	1NSG3	15520800-002	.8" DRAWER TAN with SLIDES and STD Dividers	1
4	NOT ASSIGNED	1NSG3	15981900	..SINGLE BEARING DRAWER SLIDE LEFT	1
5	NOT ASSIGNED	1NSG3	15981901	..SINGLE BEARING DRAWER SLIDE RIGHT	1
6	NOT ASSIGNED	1NSG3	15121054	...SCREW 1/4 -20 x 5/8" BH BL	8
7	NOT ASSIGNED	1NSG3	15121055	...THREADED CLIP	8
END OF FIGURE 22					

NOTE

*Item #3 available on request

0034 00-45

STANDARD MODULE DRAWERS 10" thru 16" and BULK

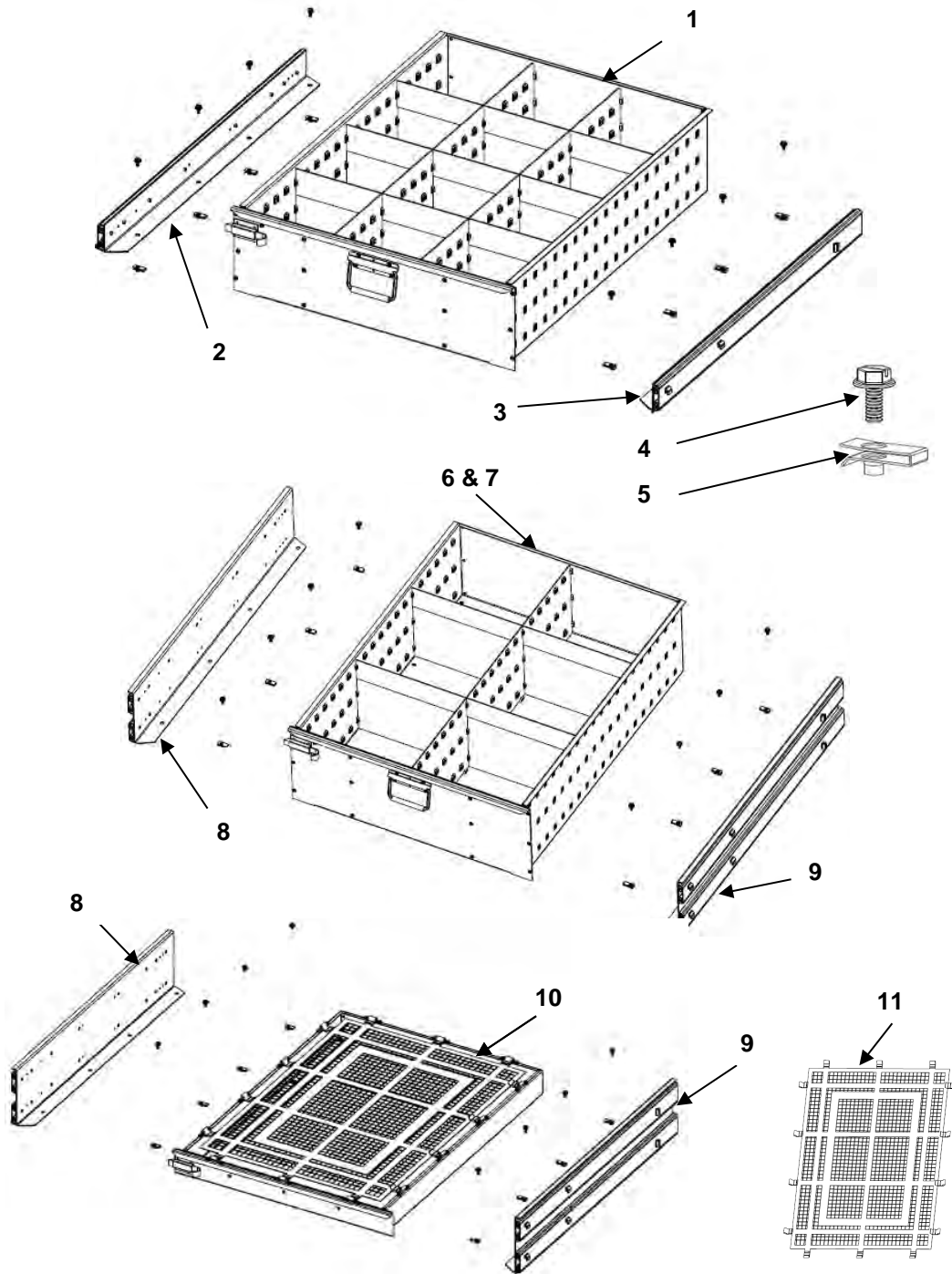

FIGURE 23 STANDARD MODULE DRAWERS 10" THRU 16" AND BULK

(1) ITEM NO.	(2) NSN	(3) CAGEC	(4) PART NUMBER	(5) DESCRIPTION AND USABLE ON CODE (UOC)	(6) QTY
				GROUP 0107 FIGURE 23 STANDARD DRAWERS 10" thru 12" and BULK	
1	8145-01-473-1351	1NSG3	15521000-001	.10" DRAWER GREEN with SLIDES and STD Dividers	1
1	8145-01-473-1351	1NSG3	15521000-002	.10" DRAWER TAN with SLIDES and STD Dividers	1
2	NOT ASSIGNED	1NSG3	15981900	..SINGLE BEARING DRAWER SLIDE LEFT	1
3	NOT ASSIGNED	1NSG3	15981901	..SINGLE BEARING DRAWER SLIDE RIGHT	1
4	NOT ASSIGNED	1NSG3	15121054	...SCREW 1/4 -20 x 5/8" BH BL	8
5	NOT ASSIGNED	1NSG3	15121055THREADED CLIP	8
6	8145-01-473-1275	1NSG3	15521200-001	.12" DRAWER GREEN with SLIDES and STD Dividers	1
6	8145-01-473-1275	1NSG3	15521200-002	.12" DRAWER TAN with SLIDES and STD Dividers	1
8	NOT ASSIGNED	1NSG3	15981902	..DOUBLE BEARING DRAWER SLIDE LEFT	1
9	NOT ASSIGNED	1NSG3	15981903	..DOUBLE BEARING DRAWER SLIDE RIGHT	1
4	NOT ASSIGNED	1NSG3	15121054	...SCREW 1/4 -20 x 5/8" BH BL	8
5	NOT ASSIGNED	1NSG3	15121055	...THREADED CLIP	8
7	8145-01-473-1527	1NSG3	15521600-001	.16" DRAWER GREEN with SLIDES and STD Dividers	1
7	8145-01-473-1527	1NSG3	15521600-002	.16" DRAWER TAN with SLIDES and STD Dividers	1
4	NOT ASSIGNED	1NSG3	15121054	...SCREW 1/4 -20 x 5/8" BH BL	8
5	NOT ASSIGNED	1NSG3	15121055	...THREADED CLIP	8
8	NOT ASSIGNED	1NSG3	15981902	..DOUBLE BEARING DRAWER SLIDE LEFT	1
9	NOT ASSIGNED	1NSG3	15981903	..DOUBLE BEARING DRAWER SLIDE RIGHT	1
10	8145-01-473-1283	1NSG3	15520001-001	.BULK DRAWER W SLIDES and NET GREEN	1
10	8145-01-473-1283	1NSG3	15520001-002	.BULK DRAWER W SLIDES and NET TAN	1
4	NOT ASSIGNED	1NSG3	15121054	...SCREW 1/4 -20 x 5/8" BH BL	8
5	NOT ASSIGNED	1NSG3	15121055	...THREADED CLIP	8
8	NOT ASSIGNED	1NSG3	15981902	..DOUBLE BEARING DRAWER SLIDE LEFT	1
9	NOT ASSIGNED	1NSG3	15981903	..DOUBLE BEARING DRAWER SLIDE RIGHT	1
11	NOT ASSIGNED	1NSG3	15522023	...BULK DRAWER NET	1
END OF FIGURE 23					

0034 00-47

This page was intentionally left blank

STANDARD MODULE DRAWER DIVIDERS 4" thru 6"

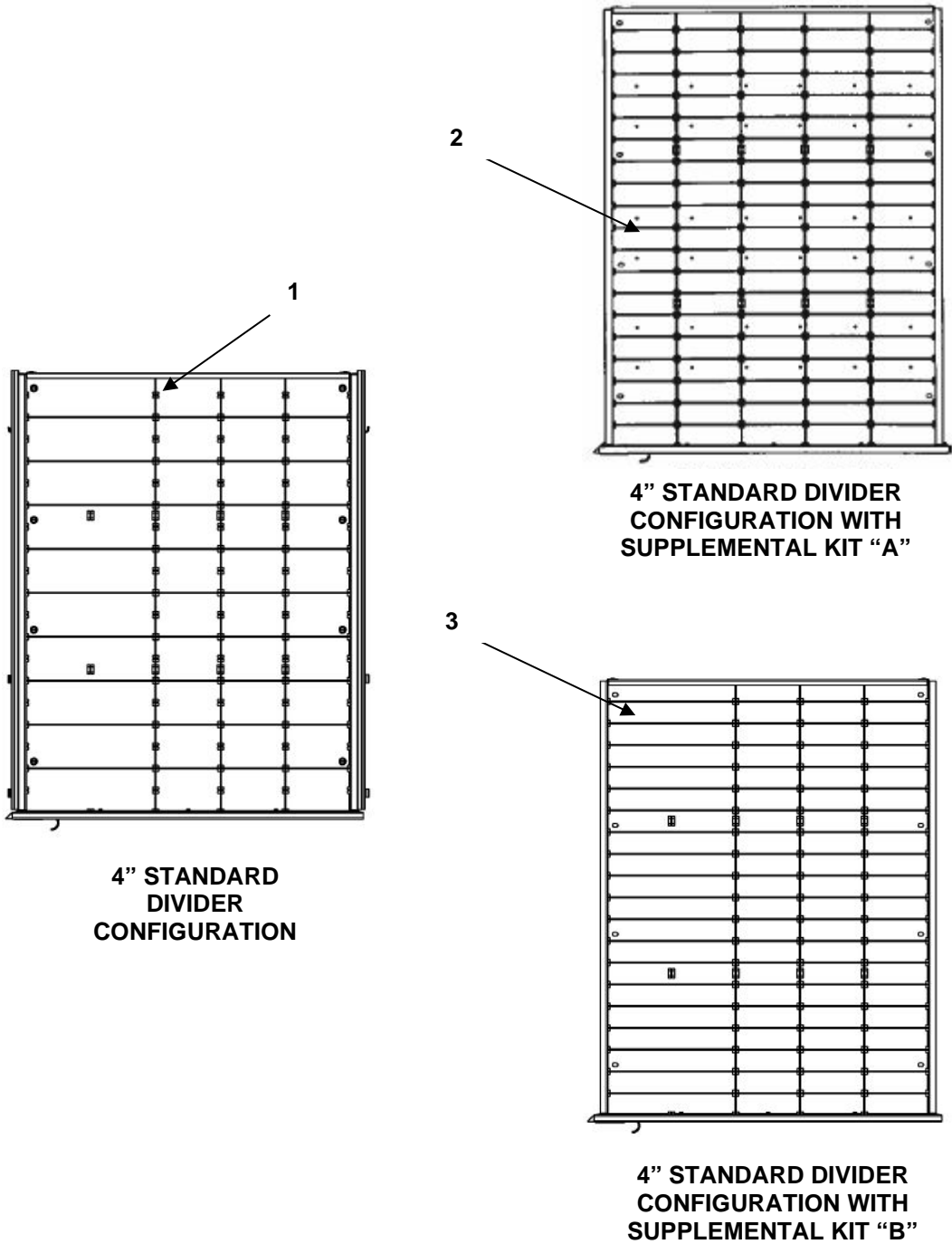

FIGURE 23A STANDARD MODULE DRAWER DIVIDERS 4" thru 6"

STANDARD MODULE DRAWER DIVIDERS 4" thru 6"

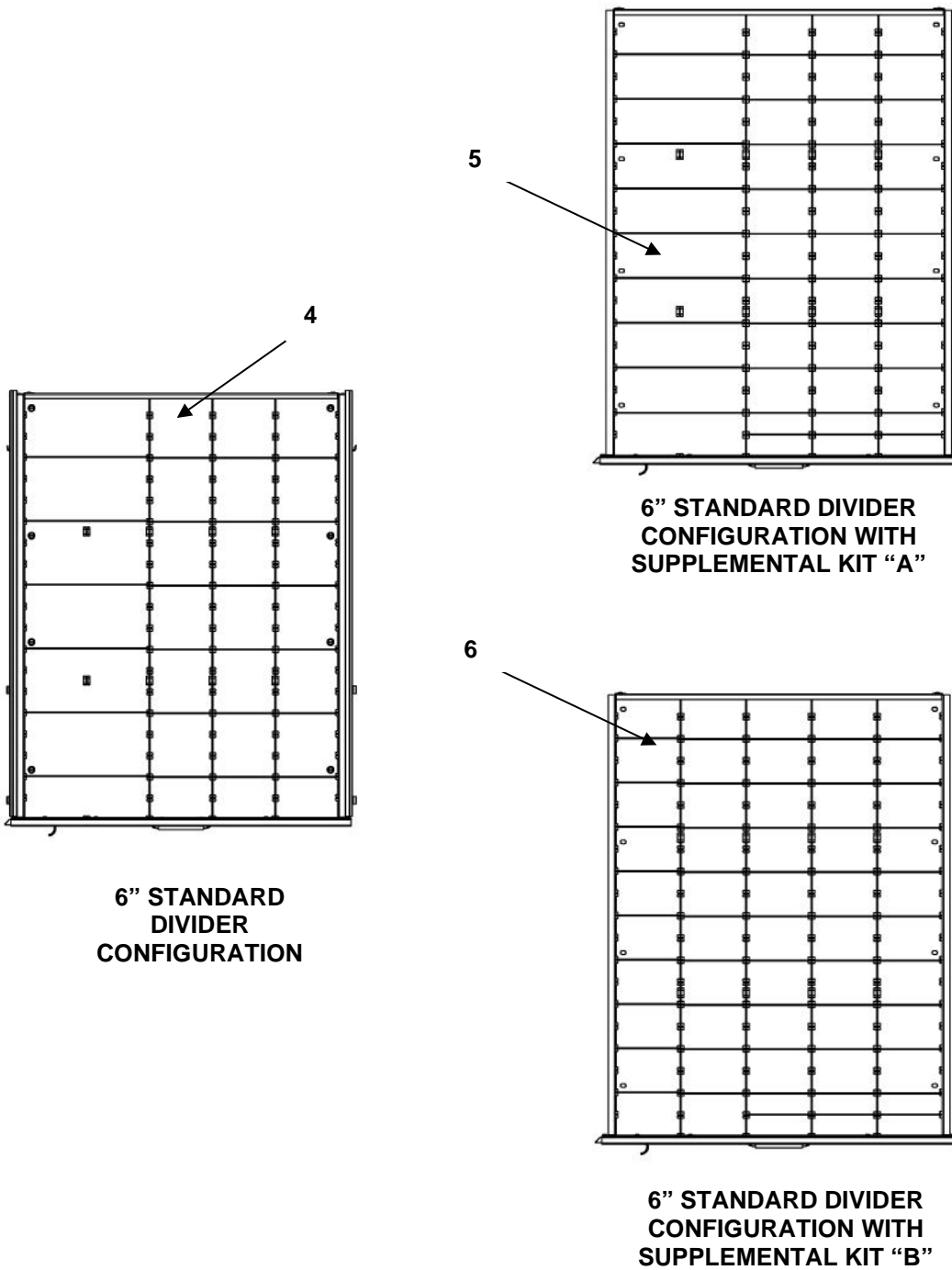
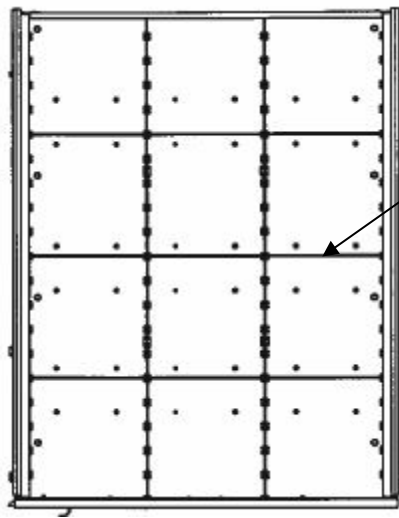

FIGURE 23A STANDARD MODULE DRAWER DIVIDERS 4" thru 6" (cont.)

(1) ITEM NO.	(2) NSN	(3) CAGEC	(4) PART NUMBER	(5) DESCRIPTION AND USABLE ON CODE (UOC)	(6) QTY
				GROUP 0107 FIGURE 23A STANDARD MODULE DRAWER DIVIDERS 4" THRU 6"	
1	NOT ASSIGNED	1NSG3	15988615	.4" STD DIVIDER CONFIGURATION	1
				..LONGITUDINAL DIVIDERS	3
				..12" LG DIVIDERS	9
				..6" LG DIVIDERS	27
2	8145-01-523-4068	1NSG3	15524001	.4" SUPP KIT "A"	1
				..LONGITUDINAL DIVIDERS	1
				..6" LG DIVIDERS	68
3	8145-01-523-4592	1NSG3	15524002	.4" SUPP KIT "B"	1
				..12" LG DIVIDERS	10
				..6" LG DIVIDERS	30
4	NOT ASSIGNED	1NSG3	15988616	.6" STD DIVIDER CONFIGURATION	1
				..LONGITUDINAL DIVIDERS	3
				..12" LG DIVIDERS	6
				..6" LG DIVIDERS	18
5	8145-01-523-4591	1NSG3	15524003	.6" SUPP KIT "A"	1
				..12" LG DIVIDERS	3
				..6" LG DIVIDERS	12
6	8145-01-523-4149	1NSG3	15524004	.6" SUPP KIT "B"	1
				..LONGITUDINAL DIVIDERS	1
				..6" LG DIVIDERS	30
END OF FIGURE 23A					

STANDARD MODULE DRAWER DIVIDERS 8" thru 16"



**8" and 10" STANDARD
DIVIDER CONFIGURATION**

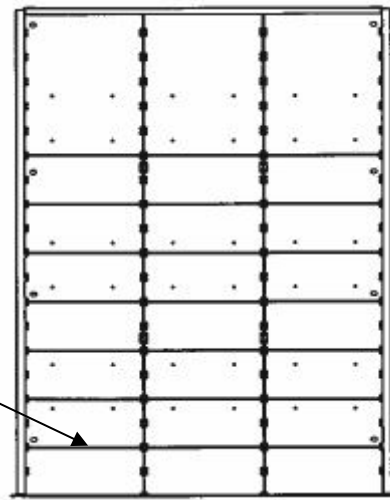

**8" and 10" STANDARD DIVIDER
CONFIGURATION WITH
SUPPLEMENTAL KIT**

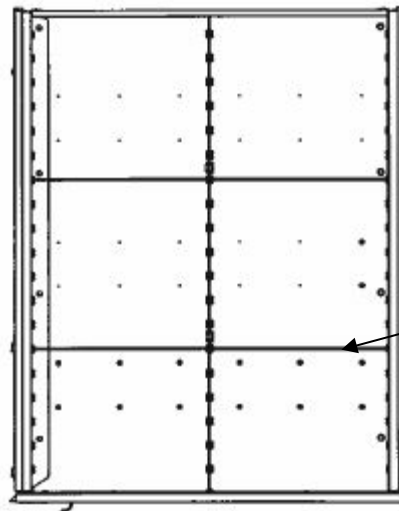

**12" and 16" STANDARD
DIVIDER CONFIGURATION**

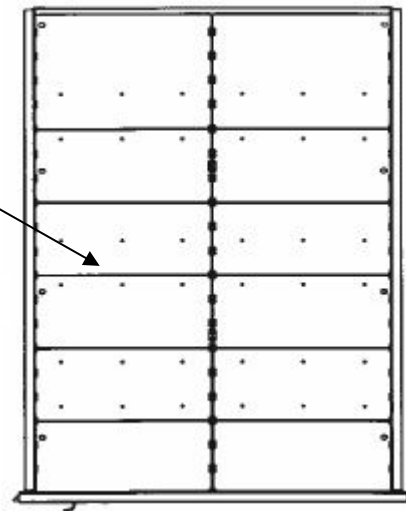

**12" and 16" STANDARD
DIVIDER CONFIGURATION
WITH SUPPLEMENTAL KIT**

FIGURE 23B STANDARD MODULE DRAWER DIVIDERS 8" thru 16"

(1) ITEM NO.	(2) NSN	(3) CAGEC	(4) PART NUMBER	(5) DESCRIPTION AND USABLE ON CODE (UOC)	(6) QTY
				GROUP 0107 FIGURE 23B STANDARD MODULE DRAWER DIVIDERS 8" THRU 16"	
1	NOT ASSIGNED	1NSG3	15988617	.8" STD DIVIDER CONFIGURATION	1
				..LONGITUDINAL DIVIDERS	2
				..10" LG DIVIDERS	9
2	8145-01-523-4145	1NSG3	15524005	.8" SUPP KIT	1
				..10" LG DIVIDERS	12
3	NOT ASSIGNED	1NSG3	15988618	.10" STD DIVIDER CONFIGURATION	1
				..LONGITUDINAL DIVIDERS	2
				..10" LG DIVIDERS	9
4	8145-01-523-4142	1NSG3	15524006	.10" SUPP KIT	1
				..10" LG DIVIDERS	12
5	NOT ASSIGNED	1NSG3	15988619	.12" STD DIVIDER CONFIGURATION	1
				..LONGITUDINAL DIVIDERS	1
				..15" LG DIVIDERS	4
6	8145-01-523-4140	1NSG3	15524007	.12" SUPP KIT	1
				..15" LG DIVIDERS	6
7	NOT ASSIGNED	1NSG3	15988620	.16" STD DIVIDER CONFIGURATION	1
				..LONGITUDINAL DIVIDERS	1
				..15" LG DIVIDERS	4
8	8145-01-523-4138	1NSG3	15524008	.16" SUPP KIT	1
				..15" LG DIVIDERS	6
END OF FIGURE 23B					

Standard/Specialized Module Casters

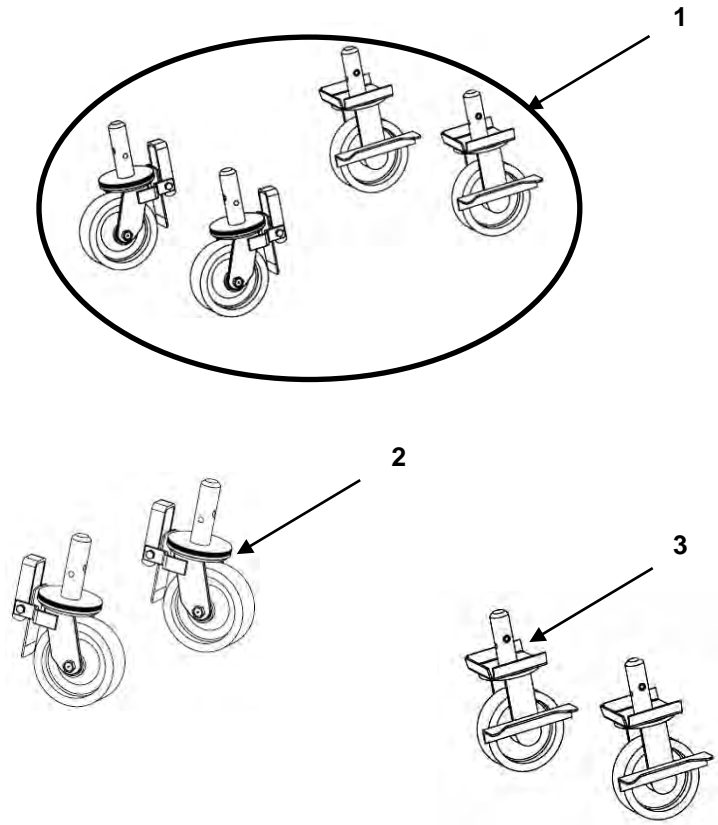

Figure 24 Standard/Specialized Module Casters

(1) ITEM NO.	(2) NSN	(3) CAGEC	(4) PART NUMBER	(5) DESCRIPTION AND USABLE ON CODE (UOC)	(6) QTY
				GROUP 0108 FIGURE 24 Standard/Specialized Module Casters	
1	NOT ASSIGNED	1NSG3	15510000	.CASTER SET (see note)	1
2	NOT ASSIGNED	1NSG3	15510101	..CASTERS FRONT SWIVEL	2
3	NOT ASSIGNED	1NSG3	15510102	..CASTERS REAR RIGID	2
END OF FIGURE 24					

NOTE

The rigid casters are no longer available as of February 2017. A module caster set will now include four swivel casters.

END OF WORK PACKAGE

This page was intentionally left blank

PARTS SUPPORTING INFORMATION

**FPU SYSTEMS OPERATION MANUAL
(INCLUDING REPAIR PARTS & SPECIAL TOOL LIST)
STANDARD AND SPECIALIZED FPU MODULES
BOH FPU Field Pack-up Units**

SPECIALIZED MODULES

SHORT HELO CABINET MODULE

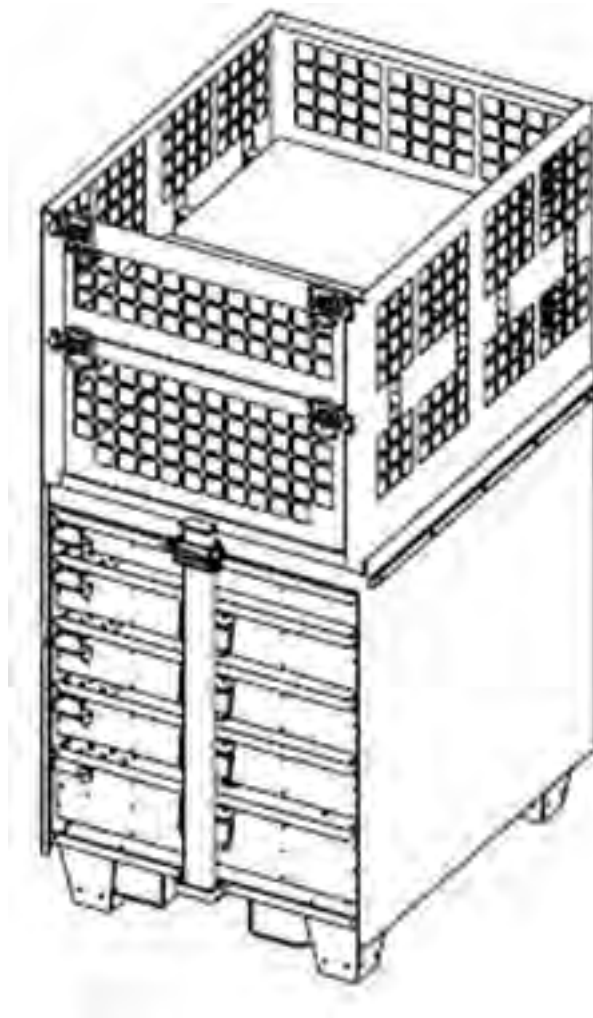

FIGURE #25 Through #29

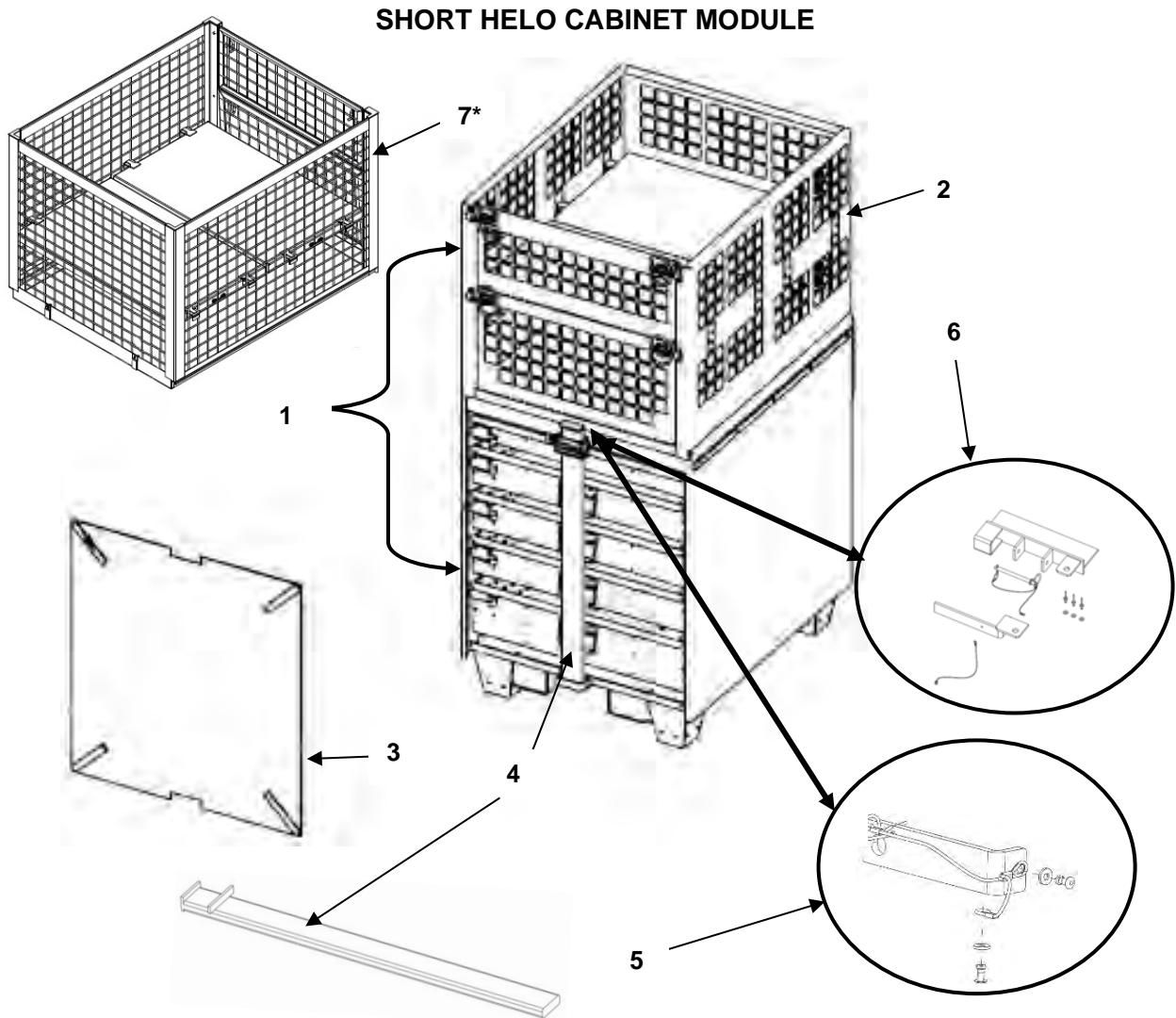

FIGURE 25 SHORT HELO CABINET MODULE WITH CAGE
NOTE
***Item # 7 is obsolete and no longer provided**

(1) ITEM NO.	(2) NSN	(3) CAGEC	(4) PART NUMBER	(5) DESCRIPTION AND USABLE ON CODE (UOC)	(6) QTY
				GROUP 0201 FIGURE 25 SHORT HELO MODULE	
1	8145-01-502-0591	1NSG3	15700201-001	.SHORT HELO CABINET GREEN with CAGE	1
2	NOT ASSIGNED	1NSG3	16500340-001	..SHORT HELO CAGE GREEN	1
3	NOT ASSIGNED	1NSG3	15522005	.FRONT COVER KIT BLACK w HARDWARE	1
4	NOT ASSIGNED	1NSG3	16500380-001	.SECURITY BAR 3G GREEN	1
5	NOT ASSIGNED	1NSG3	15988248-001	.NEW SECURITY BAR LOCK RETAINER W/HARDWARE GREEN	1
6	NOT ASSIGNED	1NSG3	16212755-001	.OLDER GREENLEAF DOUBLE SEC BAR W/PIN GREEN	1
7*	NOT ASSIGNED	1NSG3	16500150-001	*OBSOLETE SHORT HELO CAGE GREEN	N/A
1	8145-01-473-1288	1NSG3	15700201-002	.SHORT HELO CABINET TAN with CAGE	1
2	NOT ASSIGNED	1NSG3	16500340-002	..SHORT HELO CAGE TAN	1
3	NOT ASSIGNED	1NSG3	15522005	.FRONT COVER KIT BLACK W/ HARDWARE	1
4	NOT ASSIGNED	1NSG3	16500380-002	.SECURITY BAR 3G TAN	1
5	NOT ASSIGNED	1NSG3	15988248-002	.NEW SECURITY BAR LOCK RETAINER W/HARDWARE TAN	1
6	NOT ASSIGNED	1NSG3	16212755-002	.OLDER GREENLEAF DOUBLE SEC BAR W/PIN TAN	1
7*	NOT ASSIGNED	1NSG3	16500150-002	*OBSOLETE SHORT HELO CAGE TAN	N/A
END OF FIGURE 25					

NOTE***Item # 7 is obsolete and no longer provided**

SHORT HELO CAGE

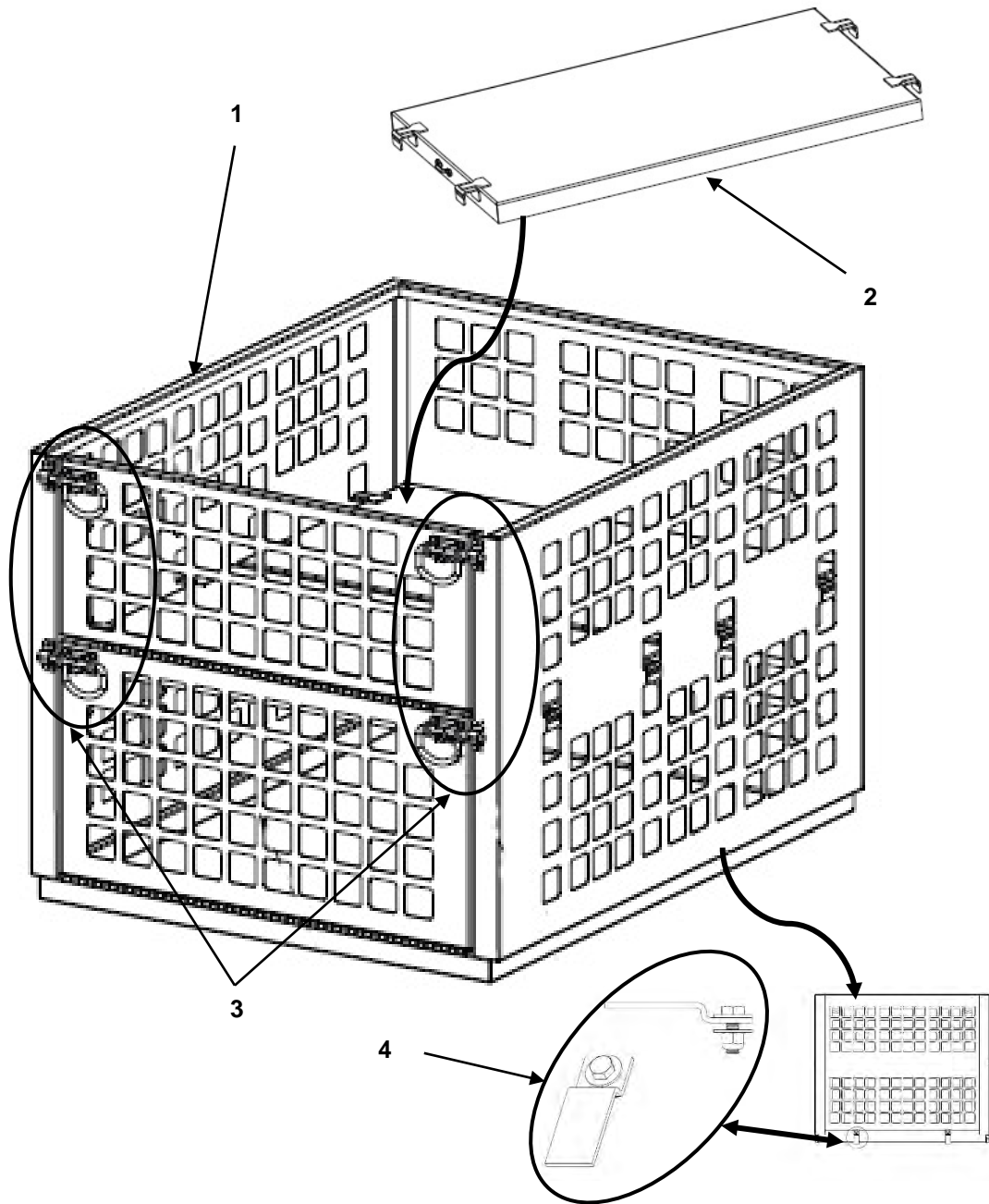

FIGURE 26 SHORT HELO CAGE

(1) ITEM NO.	(2) NSN	(3) CAGEC	(4) PART NUMBER	(5) DESCRIPTION AND USABLE ON CODE (UOC)	(6) QTY
				GROUP 020101 FIGURE 26 SHORT HELO CAGE	
1	NOT ASSIGNED	1NSG3	16500340-001	.SHORT HELO CAGE GREEN	1
2	NOT ASSIGNED	1NSG3	16500341-001	..SHELVES GREEN	2
3	NOT ASSIGNED	1NSG3	74100545-001	..GATE LATCH HANDLE GREEN	4
4	NOT ASSIGNED	1NSG3	16507365-001	..LOCK TAB ASSEMBLY W/HARDWARE GREEN	4
1	NOT ASSIGNED	1NSG3	16500340-002	.SHORT HELO CAGE TAN	1
2	NOT ASSIGNED	1NSG3	16500341-002	..SHELVES TAN	2
3	NOT ASSIGNED	1NSG3	74100545-002	..GATE LATCH HANDLE TAN	4
4	NOT ASSIGNED	1NSG3	16507365-002	..LOCK TAB ASSEMBLY W/HARDWARE TAN	4
END OF FIGURE 26					

SHORT HELO CABINET DRAWERS

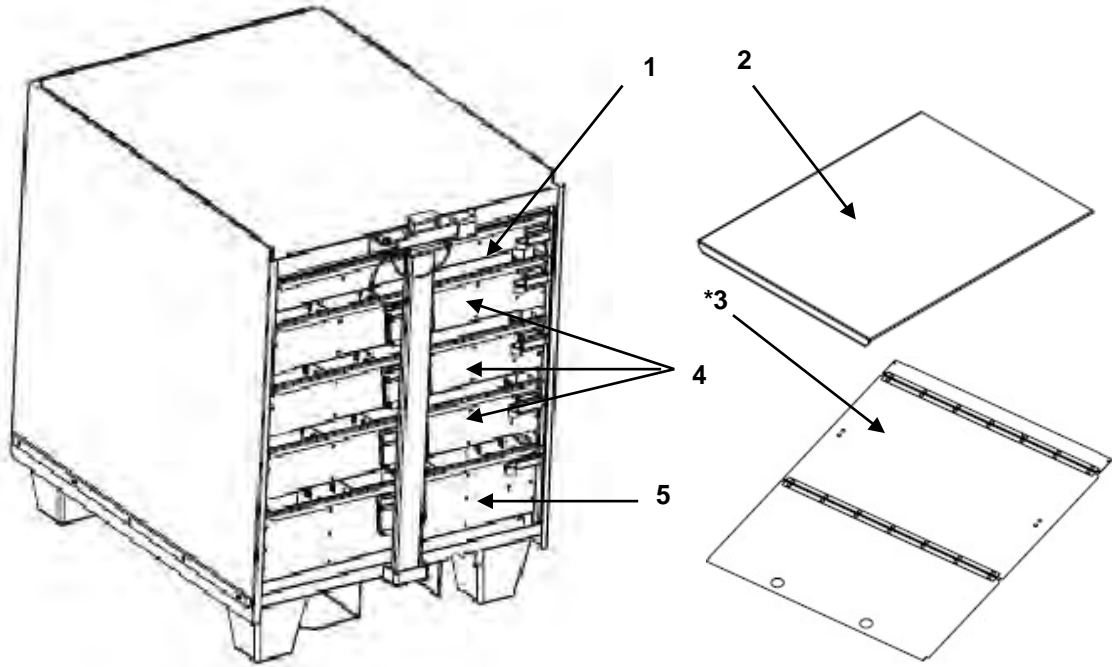

FIGURE 27 SHORT HELO CABINET DRAWERS

NOTE

Top Cage removed for clarity
*Item #3 available on request

(1) ITEM NO.	(2) NSN	(3) CAGEC	(4) PART NUMBER	(5) DESCRIPTION AND USABLE ON CODE (UOC)	(6) QTY
				GROUP 020102 FIGURE 27 SHORT HELO CABINET DRAWERS	
1	8145-01-473-1218	1NSG3	15520400-001	.4" DRAWER GREEN with SLIDES and STD Dividers	1
2	NOT ASSIGNED	1NSG3	16502505	..4" DRAWER SLIDING LID	1
3*	NOT ASSIGNED	1NSG3	16020424	..FOLDING STYLE LID 4" DRAWER *	1
4	8145-01-473-1319	1NSG3	15520600-001	.6" DRAWER GREEN with SLIDES and STD Dividers	3
5	8145-01-473-1226	1NSG3	15520800-001	.8" DRAWER GREEN with SLIDES and STD Dividers	1
1	8145-01-473-1218	1NSG3	15520400-002	.4" DRAWER TAN with SLIDES and STD Dividers	1
2	NOT ASSIGNED	1NSG3	16502505	..SLIDING LID 4" DRAWER	1
3*	NOT ASSIGNED	1NSG3	16020424	..FOLDING STYLE LID 4" DRAWER *	1
4	8145-01-473-1319	1NSG3	15520600-002	.6" DRAWER TAN with SLIDES and STD Dividers	3
5	8145-01-473-1226	1NSG3	15520800-002	.8" DRAWER TAN with SLIDES and STD Dividers	1
END OF FIGURE 27					

NOTE

*Item #3 available on request

SHORT HELO DRAWER HARDWARE

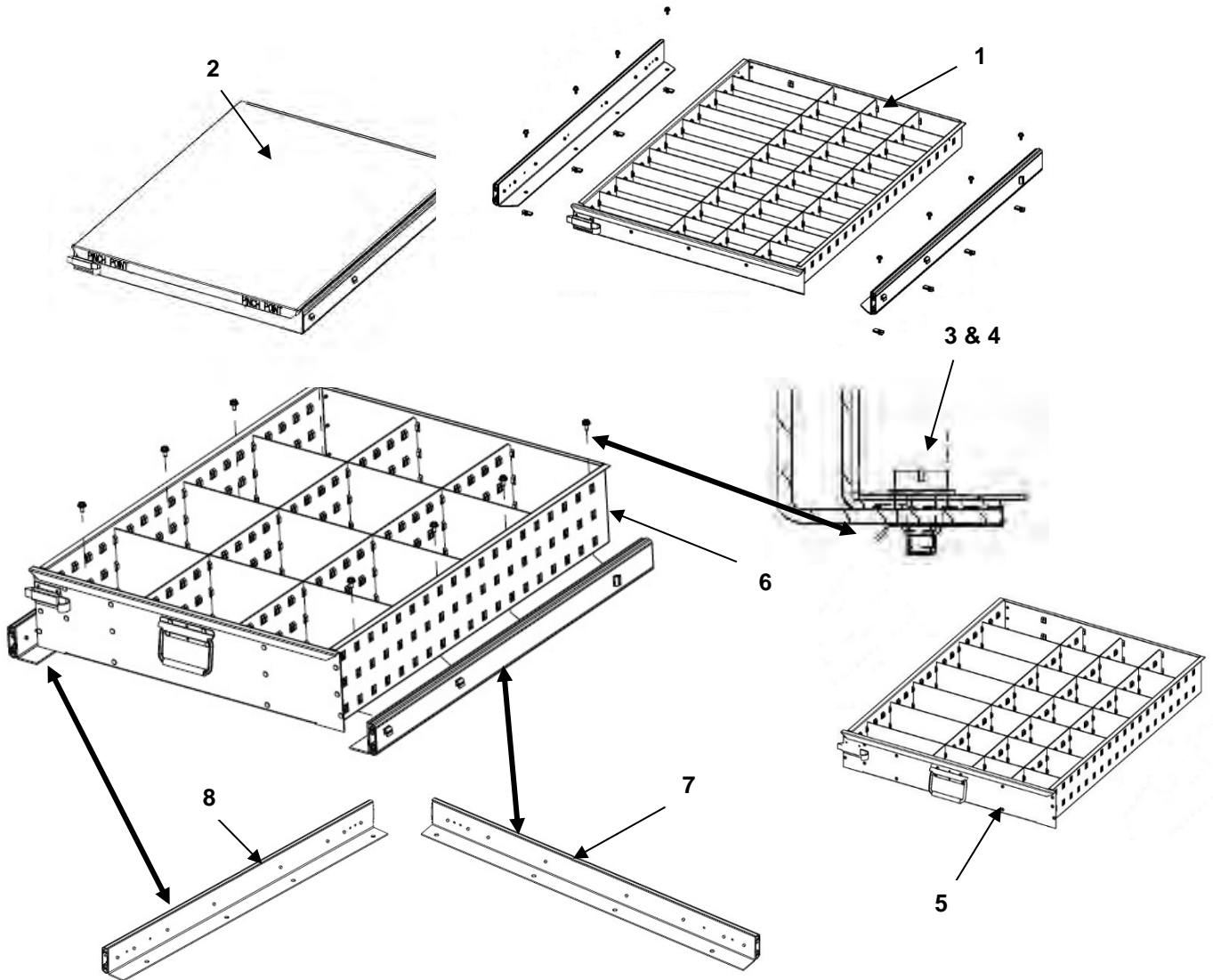

FIGURE 28 SHORT HELO DRAWER HARDWARE

(1) ITEM NO.	(2) NSN	(3) CAGEC	(4) PART NUMBER	(5) DESCRIPTION AND USABLE ON CODE (UOC)	(6) QTY
				GROUP 020103 FIGURE 28 MODULE DRAWER BEARING SLIDES and HARDWARE	
1	8145-01-473-1218	1NSG3	15520400-001	.4" DRAWER GREEN with SLIDES, STD DIVIDERS and	1
1	8145-01-473-1218	1NSG3	15520400-002	.4" DRAWER TAN with SLIDES, STD DIVIDERS and LID	1
2	NOT ASSIGNED	1NSG3	16502505	..4" DRAWER SLIDING LID	1
3	NOT ASSIGNED	1NSG3	15121054	..SCREW 1/4 -20 x 5/8" BH BL	8
4	NOT ASSIGNED	1NSG3	15121055	..THREADED CLIP	8
7	NOT ASSIGNED	1NSG3	15981901	.SINGLE BEARING DRAWER SLIDE RIGHT	1
8	NOT ASSIGNED	1NSG3	15981900	.SINGLE BEARING DRAWER SLIDE LEFT	1
5	8145-01-473-1319	1NSG3	15520600-001	.6" DRAWER GREEN with SLIDES and STD Dividers	1
5	8145-01-473-1319	1NSG3	15520600-002	.6" DRAWER TAN with SLIDES and STD Dividers	1
3	NOT ASSIGNED	1NSG3	15121054	..SCREW 1/4 -20 x 5/8" BH BL	8
4	NOT ASSIGNED	1NSG3	15121055	..THREADED CLIP	8
7	NOT ASSIGNED	1NSG3	15981901	.SINGLE BEARING DRAWER SLIDE RIGHT	1
8	NOT ASSIGNED	1NSG3	15981900	.SINGLE BEARING DRAWER SLIDE LEFT	1
6	8145-01-473-1226	1NSG3	15520800-001	.8" DRAWER GREEN with SLIDES and STD Dividers	1
6	8145-01-473-1226	1NSG3	15520800-002	.8" DRAWER TAN with SLIDES and STD Dividers	1
3	NOT ASSIGNED	1NSG3	15121054	..SCREW 1/4 -20 x 5/8" BH BL	8
4	NOT ASSIGNED	1NSG3	15121055	..THREADED CLIP	8
7	NOT ASSIGNED	1NSG3	15981901	.SINGLE BEARING DRAWER SLIDE RIGHT	1
8	NOT ASSIGNED	1NSG3	15981900	.SINGLE BEARING DRAWER SLIDE LEFT	1
ENG OF FIGURE 28					

Note: See page 0034 00-48 thru 52 for standard and supplemental drawer divider configurations.

STANDARD MODULE DRAWER DIVIDERS 4" thru 8"

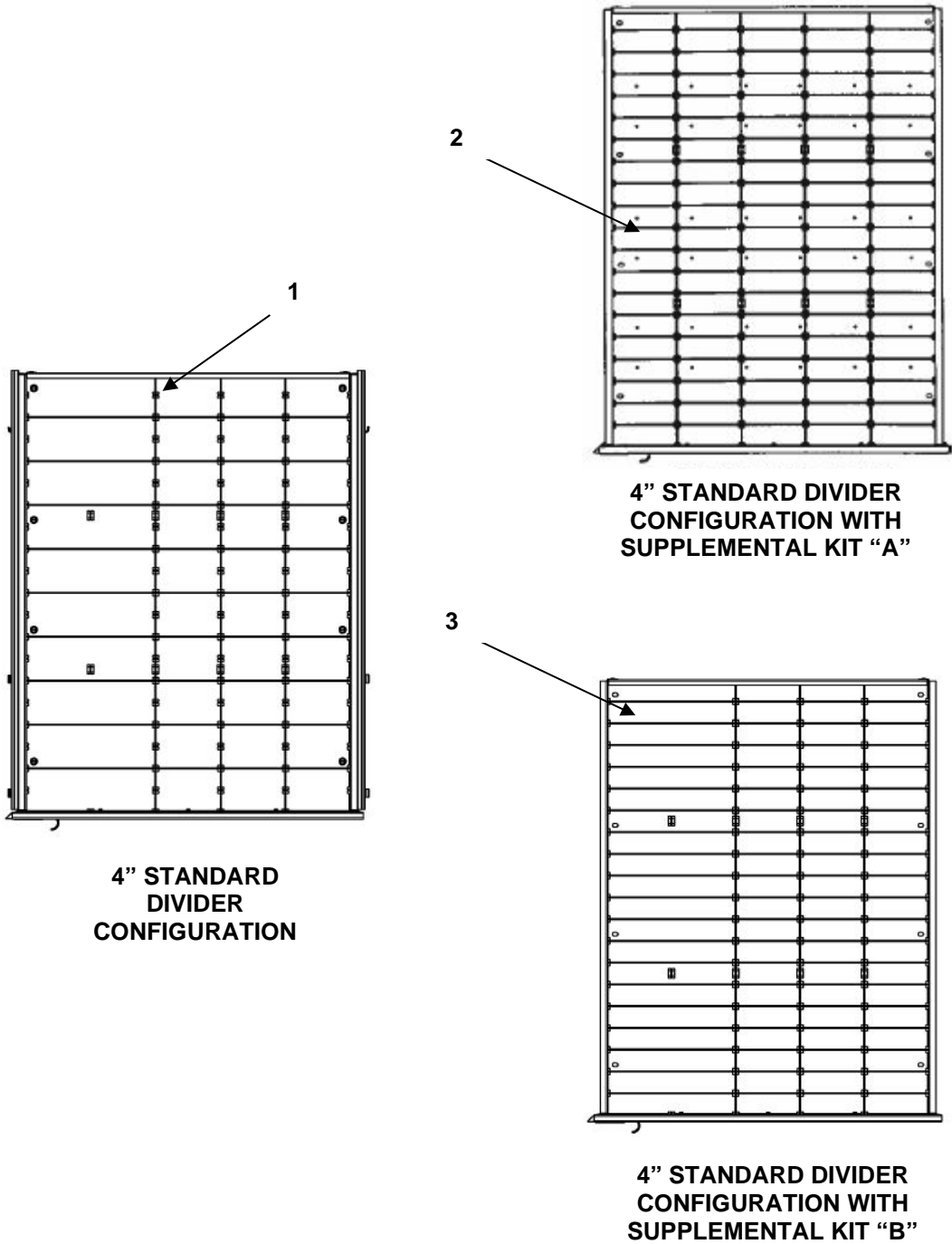

FIGURE 29 STANDARD MODULE DRAWER DIVIDERS 4" thru 8"

STANDARD MODULE DRAWER DIVIDERS 4" thru 8"

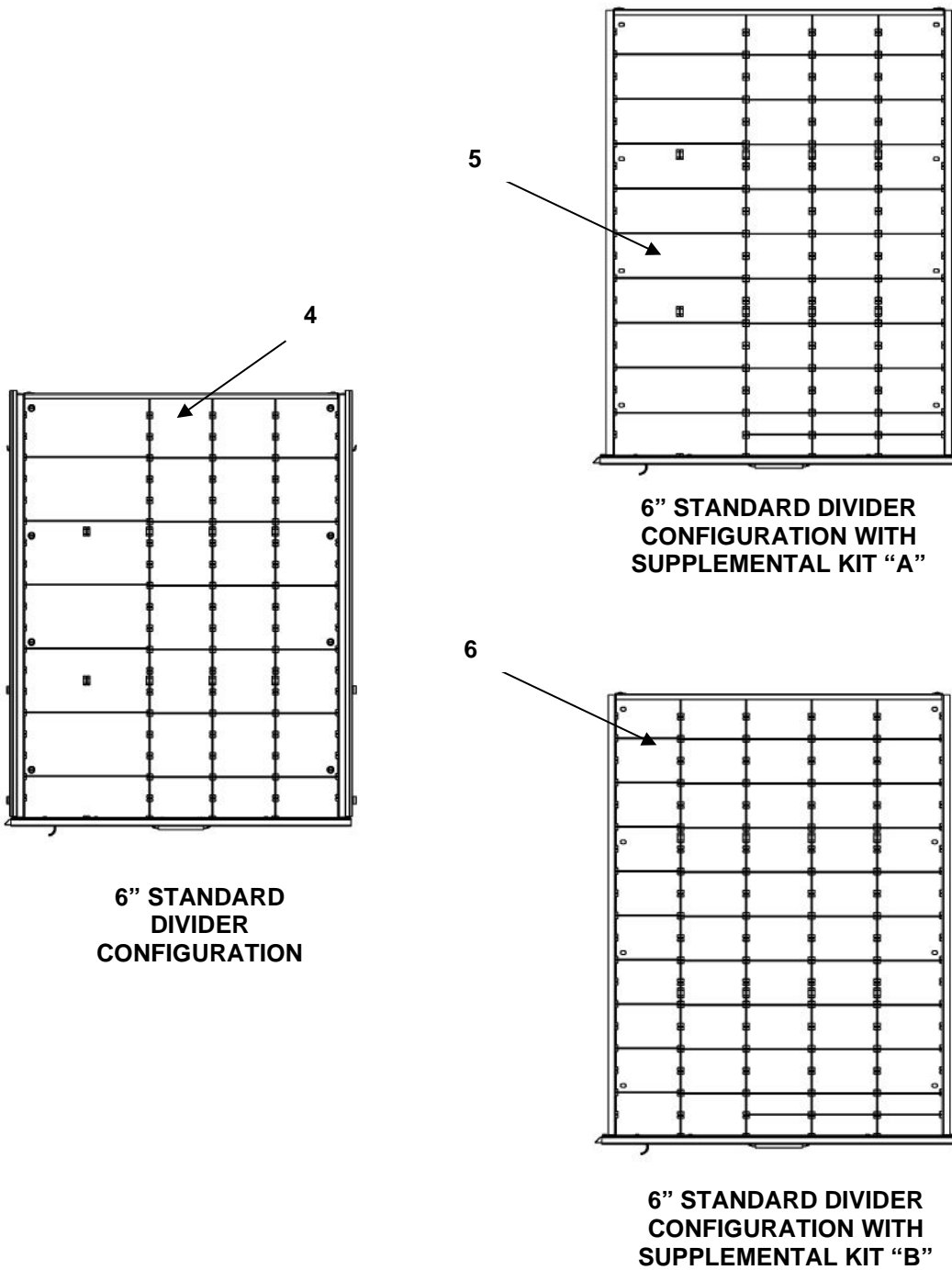

FIGURE 29 STANDARD MODULE DRAWER DIVIDERS 4" thru 8" (cont.)

STANDARD MODULE DRAWER DIVIDERS 4" thru 8"

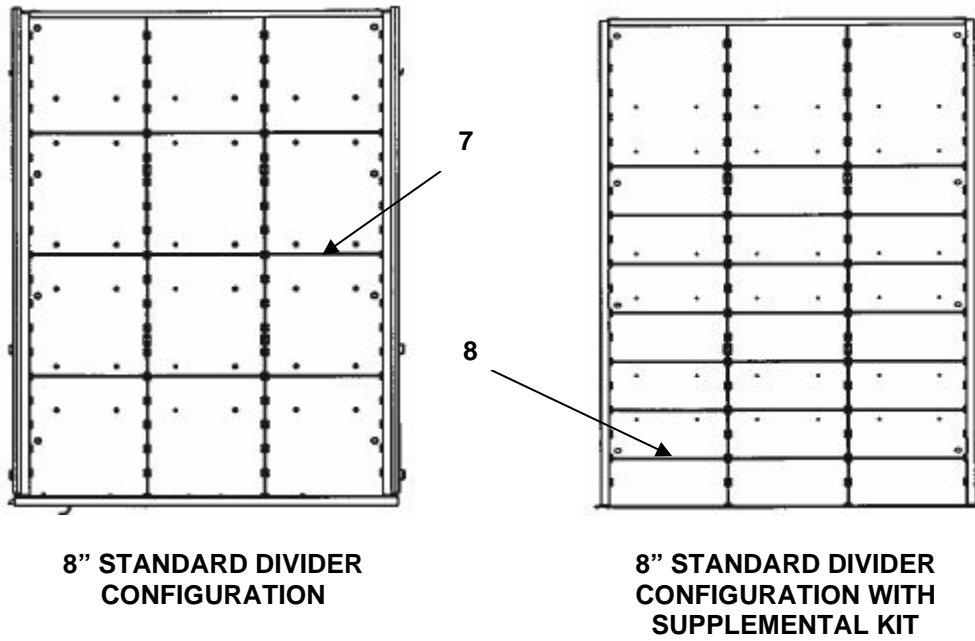

FIGURE 29 STANDARD MODULE DRAWER DIVIDERS 4" thru 8" (cont.)

(1) ITEM NO.	(2) NSN	(3) CAGEC	(4) PART NUMBER	(5) DESCRIPTION AND USABLE ON CODE (UOC)	(6) QTY
				GROUP 020104 FIGURE 29 DRAWER DIVIDER SETS	
1	NOT ASSIGNED	1NSG3	15988615	.4" STD DIVIDER CONFIGURATION	1
				..LONGITUDINAL DIVIDERS	3
				..12" LG DIVIDERS	9
				..6" LG DIVIDERS	27
2	8145-01-523-4068	1NSG3	15524001	.4" SUPP KIT "A"	1
				..LONGITUDINAL DIVIDERS	1
				..6" LG DIVIDERS	68
3	8145-01-523-4592	1NSG3	15524002	.4" SUPP KIT "B"	1
				..12" LG DIVIDERS	10
				..6" LG DIVIDERS	30
4	NOT ASSIGNED	1NSG3	15988616	.6" STD DIVIDER CONFIGURATION	1
				..LONGITUDINAL DIVIDERS	3
				..12" LG DIVIDERS	6
				..6" LG DIVIDERS	18
5	8145-01-523-4591	1NSG3	15524003	.6" SUPP KIT "A"	1
				..12" LG DIVIDERS	3
				..6" LG DIVIDERS	12
6	8145-01-523-4149	1NSG3	15524004	.6" SUPP KIT "B"	1
				..LONGITUDINAL DIVIDERS	1
				..6" LG DIVIDERS	30
7	NOT ASSIGNED	1NSG3	15988617	.8" STD DIVIDER CONFIGURATION	1
				..LONGITUDINAL DIVIDERS	2
				..10" LG DIVIDERS	9
8	8145-01-523-4145	1NSG3	15524005	.8" SUPP KIT	1
				..10" LG DIVIDERS	12
END OF FIGURE 29					

END OF WORK PACKAGE

This page was intentionally left blank

**PARTS SUPPORTING INFORMATION
FPU SYSTEMS OPERATION MANUAL
(INCLUDING REPAIR PARTS & SPECIAL TOOL LIST)
STANDARD AND SPECIALIZED FPU MODULES
BOH FPU Field Pack-up Unit**

SPECIALIZED MODULES

WEAPONS VAULT MODULE

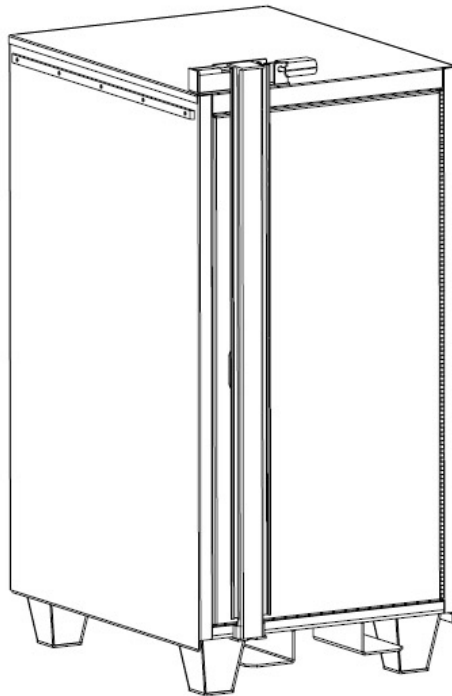

FIGURE #30 through #37

WEAPONS VAULT MODULE

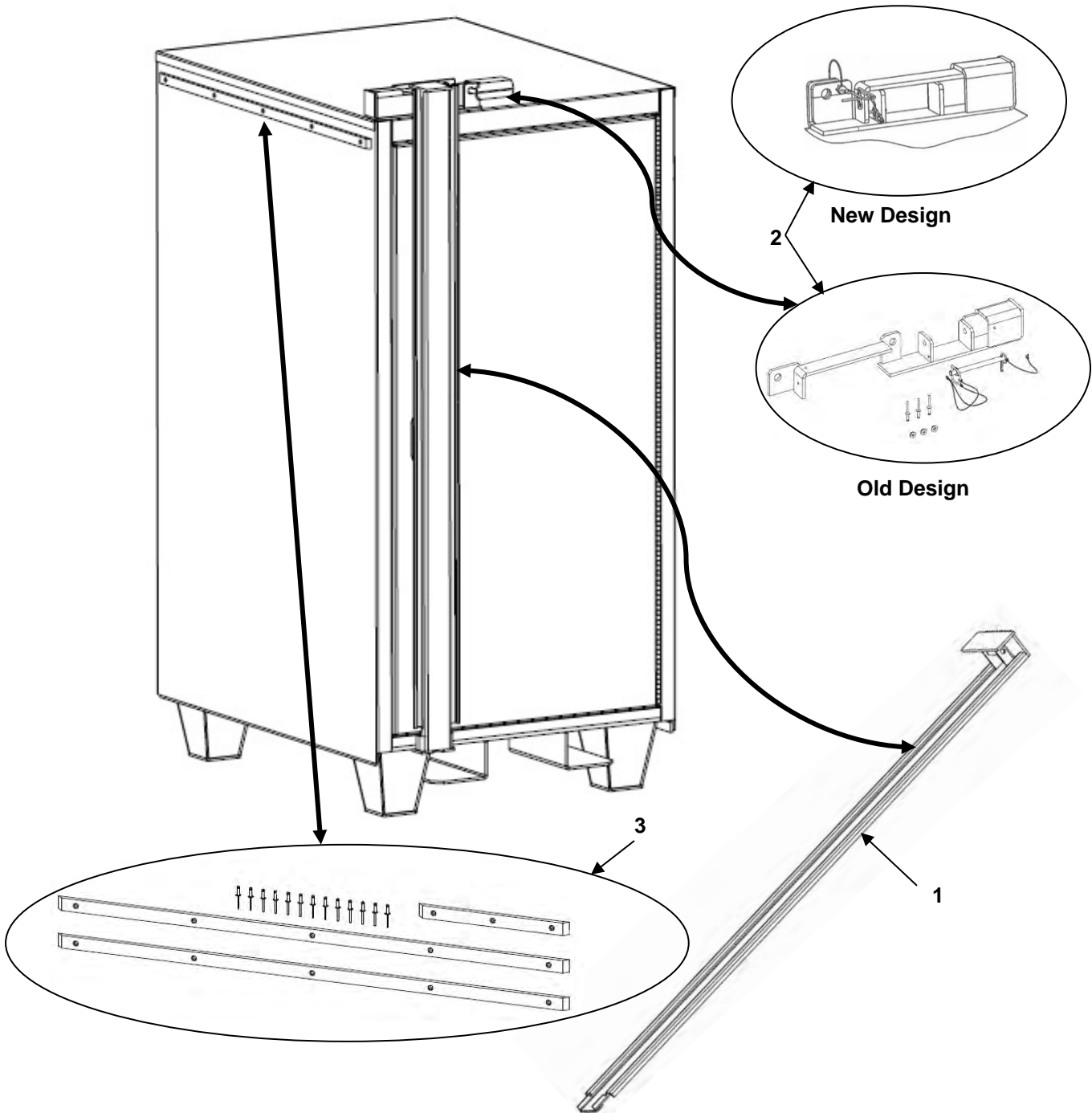

FIGURE 30 WEAPONS VAULT MODULE

(1) ITEM NO.	(2) NSN	(3) CAGE C	(4) PART NUMBER	(5) DESCRIPTION AND USABLE ON CODE (UOC)	(6) QTY
				GROUP 0202 FIGURE 30 WEAPONS VAULT MODULE	
1	NOT ASSIGNED	1NSG3	15981883-001	.WEAPON MODULE SECURITY BAR GREEN (old design)	1
1*	NOT ASSIGNED	1NSG3	15981898-001	.WEAPON MODULE SECURITY BAR GREEN (new design)	1
2	NOT ASSIGNED	1NSG3	15988715-001	.SGT GREEN LEAF BAR and PIN ASSY. GREEN (old design)	1
2*	NOT ASSIGNED	1NSG3	15981899-001	.SGT GREEN LEAF BAR - GREEN (new design)	1
3	NOT ASSIGNED	1NSG3	1588249	.BUMPER STRIP KIT	1
1	NOT ASSIGNED	1NSG3	15981883-002	.WEAPON MODULE SECURITY BAR TAN (old design)	1
1*	NOT ASSIGNED	1NSG3	15981898-002	.WEAPON MODULE SECURITY BAR TAN (new design)	1
2	NOT ASSIGNED	1NSG3	15988715-002	.SGT GREEN LEAF BAR - TAN (old design)	1
2*	NOT ASSIGNED	1NSG3	15981899-002	.SGT GREEN LEAF BAR - TAN (new design)	1
3	NOT ASSIGNED	1NSG3	15988249	.BUMPER STRIP KIT	1
END OF FIGURE 30					

NOTE: *New design beginning with serial number AC15500003-047444 includes removal of securing pin (and accompanying holes in padlock bar and base) and addition of round snap pin adjacent to padlock (Item 2*). Also includes removal of pin holes from security bar (Item 1*).

WEAPONS VAULT MODULE
Door removed for clarity

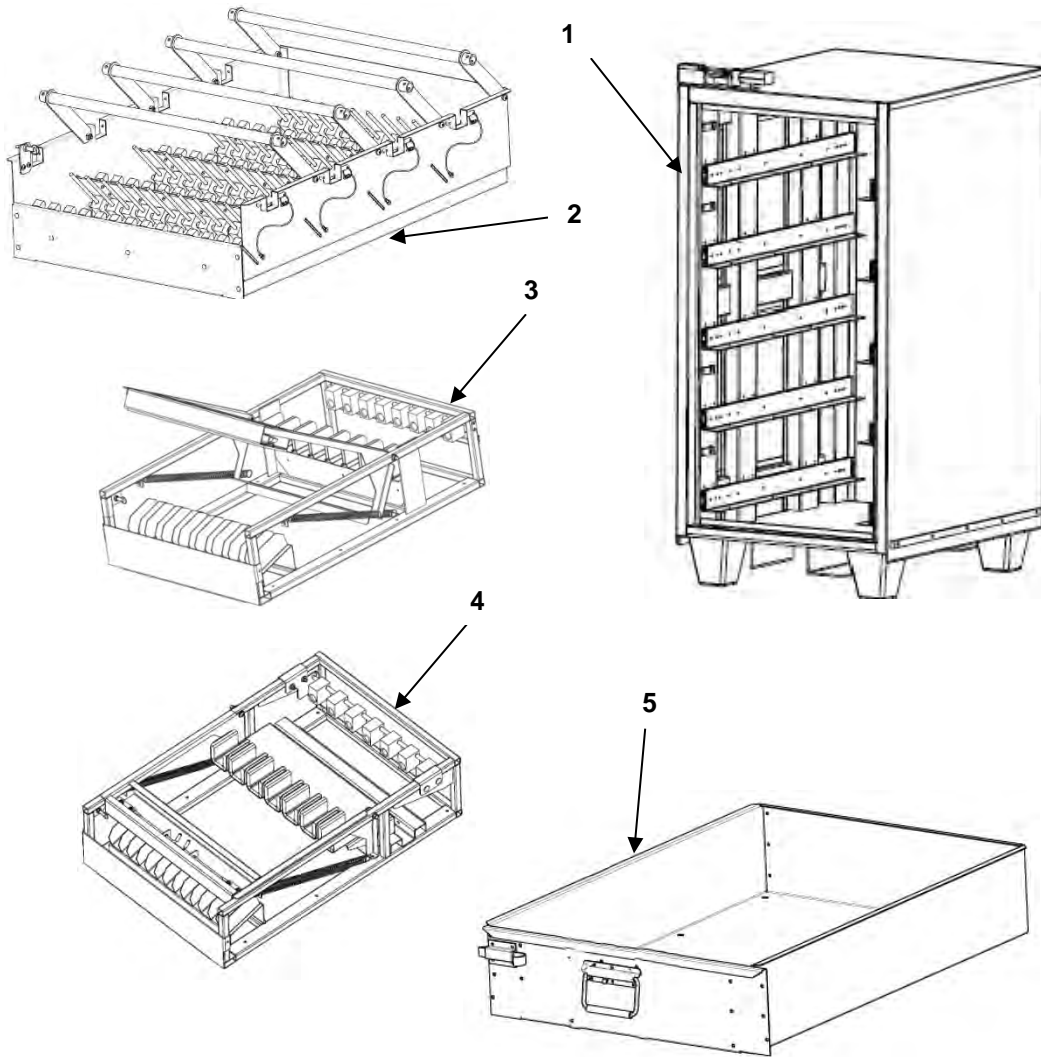

FIGURE 31 WEAPONS VAULT MODULE

(1) ITEM NO.	(2) NSN	(3) CAGE C	(4) PART NUMBER	(5) DESCRIPTION AND USABLE ON CODE (UOC)	(6) QTY
				GROUP 0202 FIGURE 31 WEAPONS VAULT MODULE	
1	8145-01-502-2593	1NSG3	15500003-001	.WEAPONS VAULT MODULE GREEN	1
2	8145-01-502-2611	1NSG3	15500102-001	..9mm PISTOL DRAWER GREEN	AR
3	8145-01-502-2605	1NSG3	15500103-001	..M16 A2 RIFLE DRAWER GREEN	AR
4	NOT ASSIGNED	1NSG3	15500104-001	..M16/M4 RIFLE DRAWER GREEN	AR
5	8145-01-528-2853	1NSG3	15520860-001	..8" BULK MATERIAL DRAWER GREEN	AR
1	8145-01-502-2593	1NSG3	15500003-002	.WEAPONS VAULT MODULE TAN	1
2	8145-01-502-2611	1NSG3	15500102-002	..9mm PISTOL DRAWER TAN	AR
3	8145-01-502-2605	1NSG3	15500103-002	.. M16 A2 RIFLE DRAWER TAN	AR
4	NOT ASSIGNED	1NSG3	15500104-002	.. M16/M4 RIFLE DRAWER W/SLIDES TAN	AR
5	8145-01-528-2853	1NSG3	15520860-002	..8" BULK MATERIAL DRAWER TAN	AR
END OF FIGURE 31					

NOTE

Vault drawer arrangements are (AR) as required

WEAPONS VAULT DRAWER SLIDES
Door removed for clarity

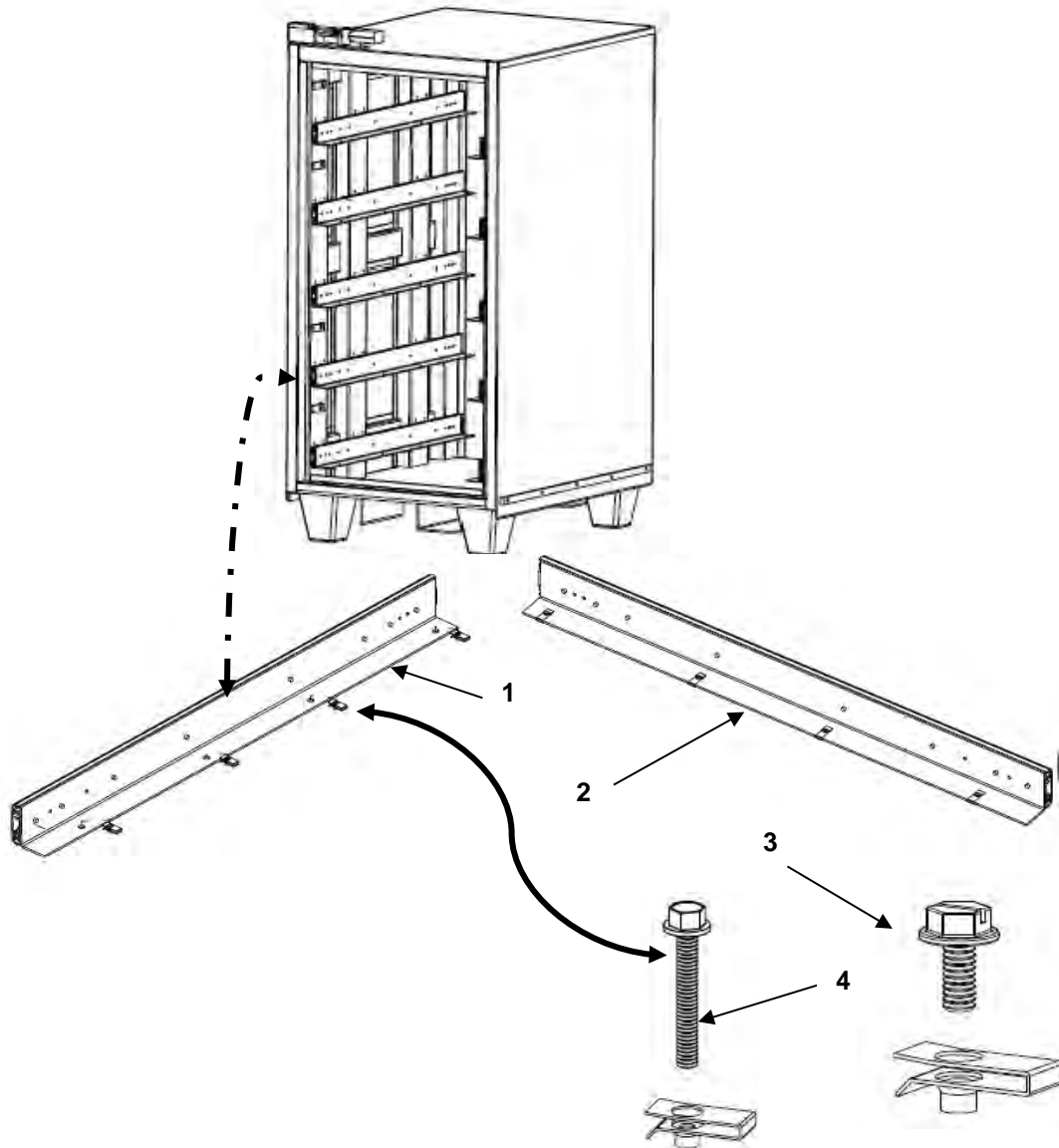

FIGURE 32 WEAPONS VAULT DRAWER SLIDES

(1) ITEM NO.	(2) NSN	(3) CAGEC	(4) PART NUMBER	(5) DESCRIPTION AND USABLE ON CODE (UOC)	(6) QTY
				GROUP 020201 FIGURE 32 WEAPONS VAULT DRAWER SLIDES	
1	NOT ASSIGNED	1NSG3	15981876	.WEAPONS VAULT DRAWER SLIDE LEFT	5
2	NOT ASSIGNED	1NSG3	15981875	.WEAPONS VAULT DRAWER SLIDE RIGHT	5
3	NOT ASSIGNED	1NSG3	15981879	.. 8" DRAWER SLIDE HARDWARE KIT	1
4	NOT ASSIGNED	1NSG3	15988612	.. WEAPONS DRAWER HARDWARE KIT	1
END OF FIGURE 32					

DOOR ASSEMBLY

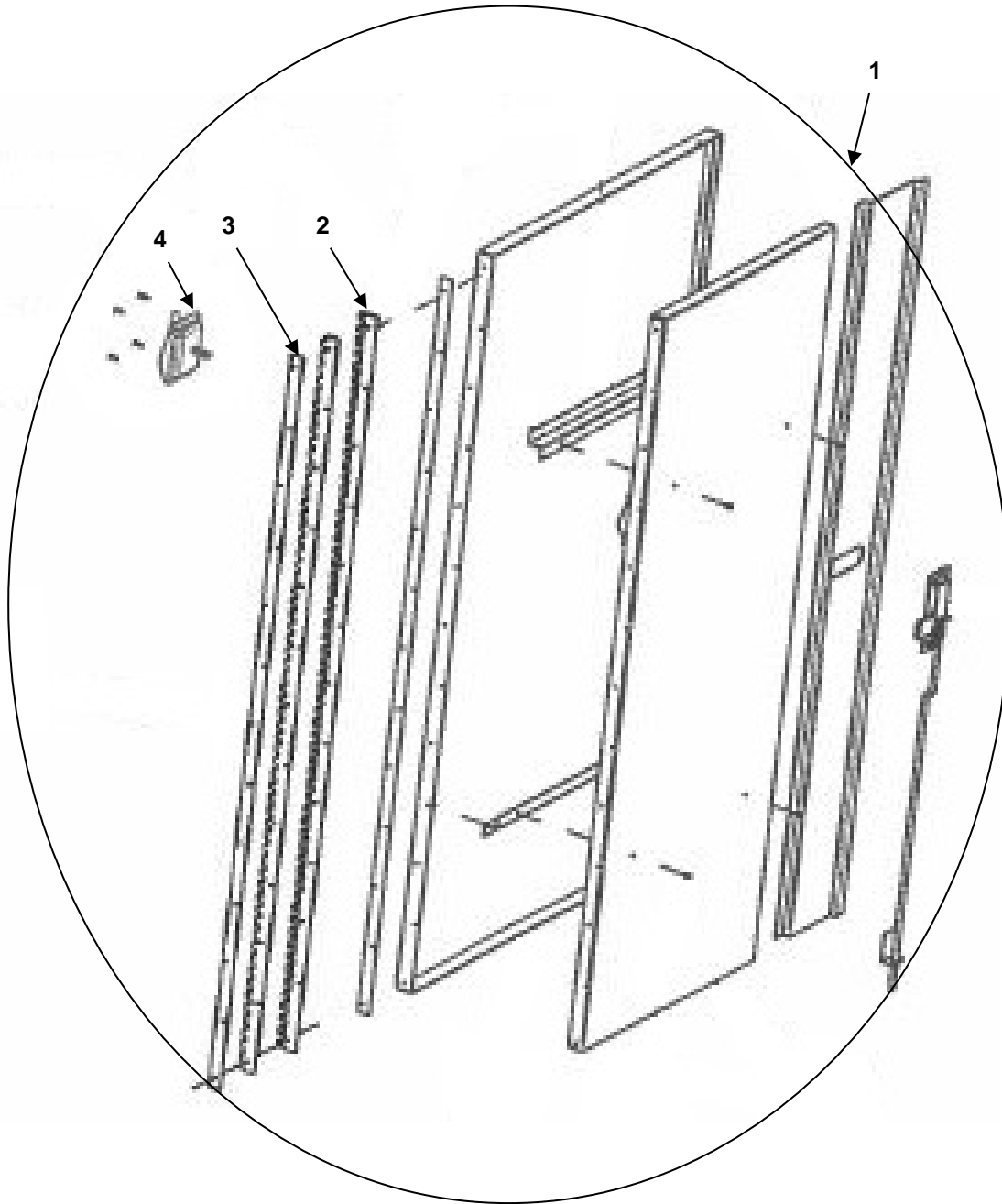

FIGURE 32A DOOR ASSEMBLY

0036 00-8

(1) ITEM NO.	(2) NSN	(3) CAGEC	(4) PART NUMBER	(5) DESCRIPTION AND USABLE ON CODE (UOC)	(6) QTY
				GROUP 020202 FIGURE 32A DOOR ASSEMBLY	
1	NOT ASSIGNED	1NSG3	16035014	.WEAPONS HULL DOOR ASSEMBLY	1
2	NOT ASSIGNED	1NSG3	15108440	..DOOR HINGE	1
3	NOT ASSIGNED	1NSG3	16030038	..SHIM FOR DOOR HINGE	1
4	NOT ASSIGNED	1NSG3	15100310	..DOOR FOLDING T- HANDLE	1
END OF FIGURE 32A					

WEAPONS VAULT DOOR SEALS
Door removed for clarity

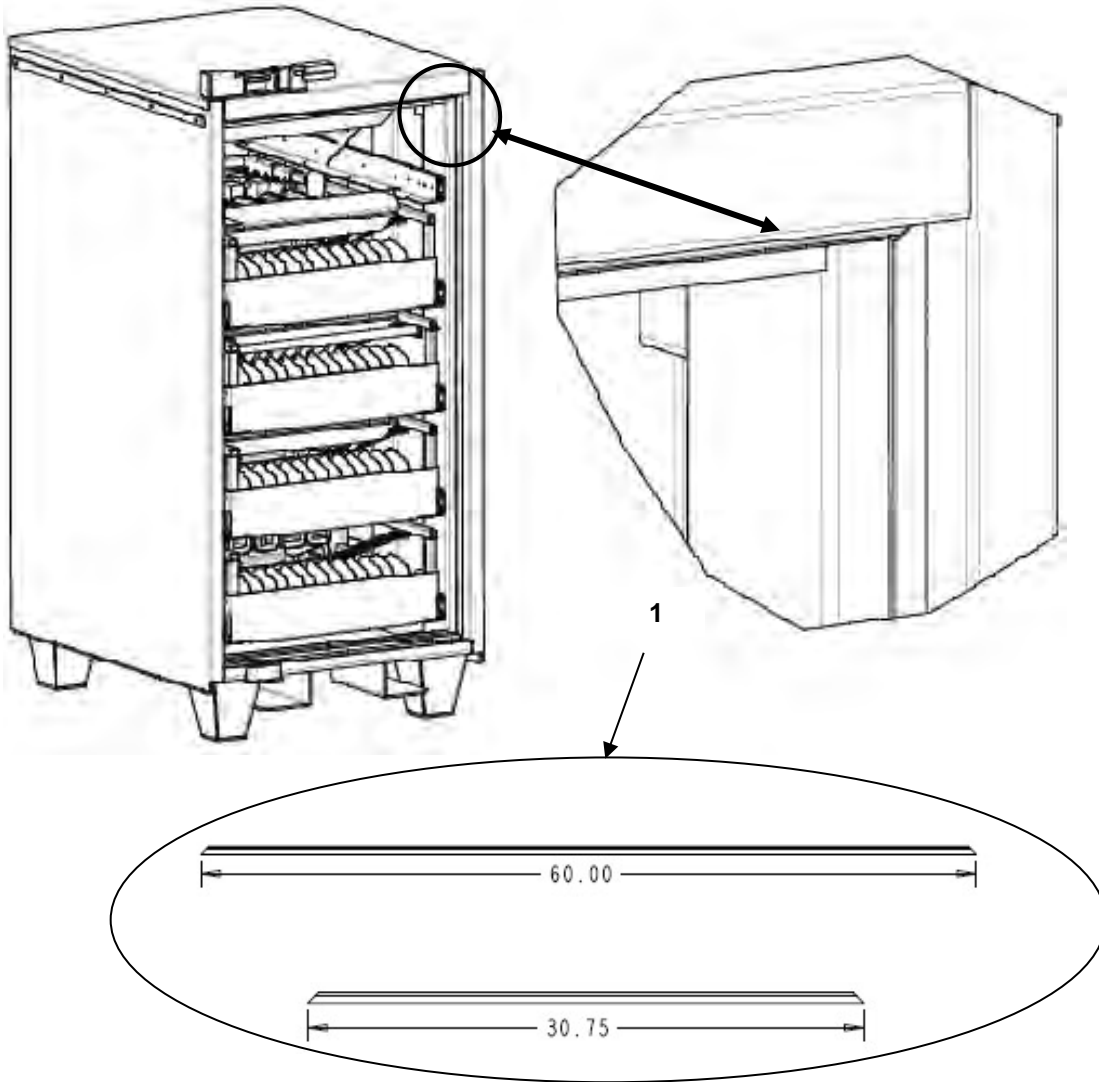

FIGURE 33 WEAPONS VAULT DOOR SEALS

1) ITEM NO.	(2) NSN	(3) CAGEC	(4) PART NUMBER	(5) DESCRIPTION AND USABLE ON CODE (UOC)	(6) QTY
				GROUP 020203 FIGURE 33 WEAPONS VAULT DOOR SEALS	
1	NOT ASSIGNED	1NSG3	15988700	.DOOR GASKET KIT W/ ADHESIVE	1
END OF FIGURE 33					

M16-A2 RIFLE DRAWER

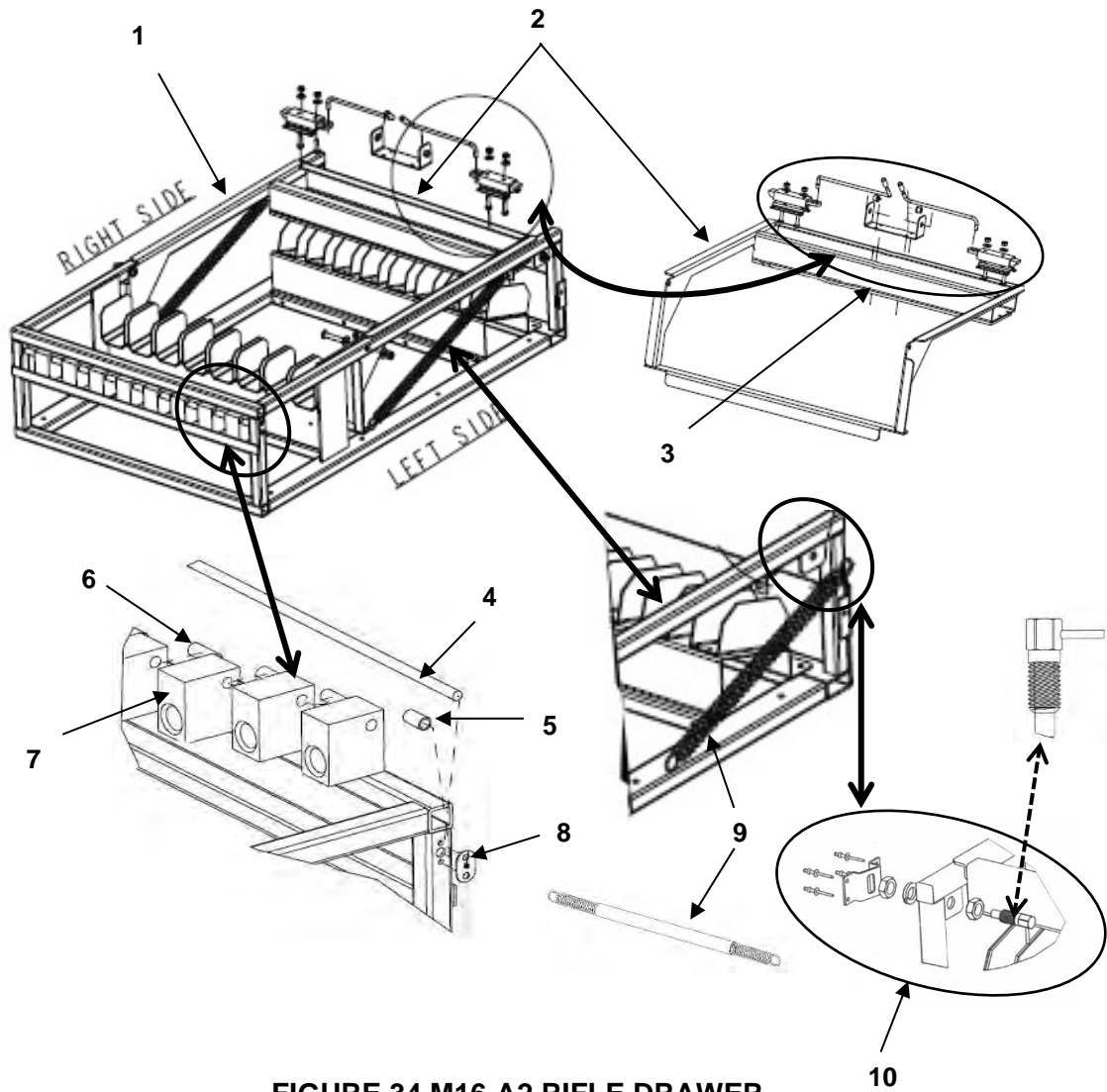

FIGURE 34 M16-A2 RIFLE DRAWER

(1) ITEM NO.	(2) NSN	(3) CAGEC	(4) PART NUMBER	(5) DESCRIPTION AND USABLE ON CODE (UOC)	(6) QTY
				GROUP 020204 FIGURE 34 WEAPONS VAULT M 16-A2 DRAWER	
1*	8145-01-502-2605	1NSG3	15500103-001	.M16-A2 RIFLE DRAWER GREEN	AR
2	NOT ASSIGNED	1NSG3	15988733-001	.. LOCK ARM ASSEMBLY GREEN	1
3	NOT ASSIGNED	1NSG3	15981894	... SLAM LATCH HARDWARE KIT	2
4	NOT ASSIGNED	1NSG3	16141628	...MUZZLE BLOCK ROD	1
5	NOT ASSIGNED	1NSG3	16141639	...MUZZLE BLOCK SPACER A 7/8"	1
6	NOT ASSIGNED	1NSG3	16141641	... MUZZLE BLOCK SPACER B 1 1/4"	8
7	NOT ASSIGNED	1NSG3	15080130	..M16 A2 MUZZLE BLOCK	8
8	NOT ASSIGNED	1NSG3	16141627	..MUZZLE BLOCK ROD COVER PLATE	2
9	NOT ASSIGNED	1NSG3	15988734	..LOCK ARM SPRINGS W/GUARDS	2
10	NOT ASSIGNED	1NSG3	15988720	..DRAWER LATCH PIN KIT	1
1*	8145-01-502-2605	1NSG3	15500103-002	.M16 A2 RIFLE DRAWER TAN	AR
2	NOT ASSIGNED	1NSG3	15988733-002	.. LOCK ARM ASSEMBLY TAN	1
3	NOT ASSIGNED	1NSG3	15981894	... SLAM LATCH HARDWARE KIT	2
4	NOT ASSIGNED	1NSG3	16141628	...MUZZLE BLOCK ROD	1
5	NOT ASSIGNED	1NSG3	16141639	...MUZZLE BLOCK SPACER A 7/8"	1
6	NOT ASSIGNED	1NSG3	16141641	... MUZZLE BLOCK SPACER B 1 1/4"	8
7	NOT ASSIGNED	1NSG3	15080130	..M16-A2 MUZZLE BLOCK	8
8	NOT ASSIGNED	1NSG3	16141627	..MUZZLE BLOCK ROD COVER PLATE	2
9	NOT ASSIGNED	1NSG3	15988734	..LOCK ARM SPRINGS W/GUARDS	2
10	NOT ASSIGNED	1NSG3	15988720	..DRAWER LATCH PIN KIT	1
END OF FIGURE 34					

NOTE

*Drawer slides included with module hull.

M16/M4 RIFLE DRAWER

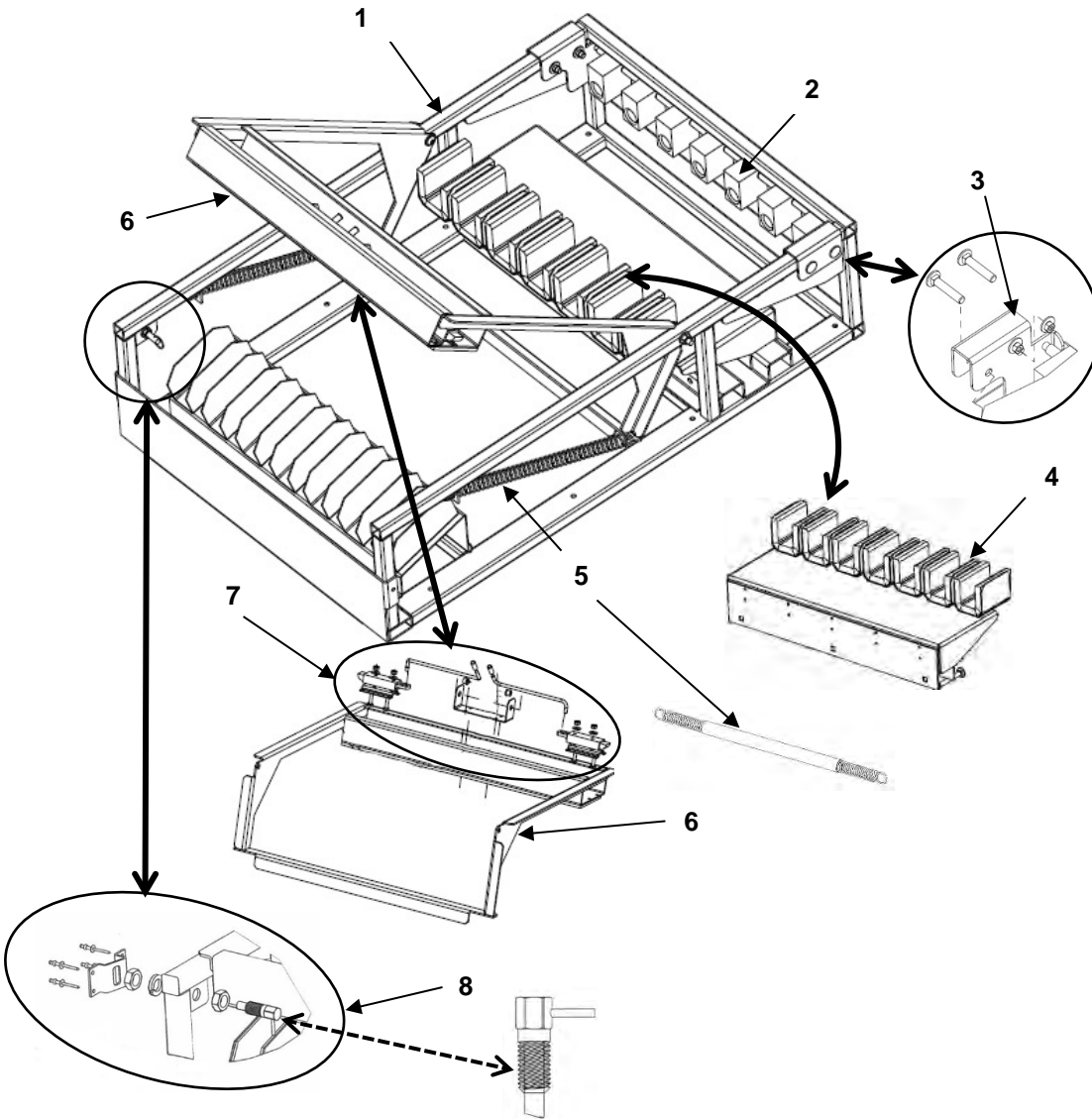

FIGURE 35 M16/M4 RIFLE DRAWER

1) ITEM NO.	(2) NSN	(3) CAGEC	(4) PART NUMBER	(5) DESCRIPTION AND USABLE ON CODE (UOC)	(6) QTY
				GROUP 020205 FIGURE 35 WEAPONS VAULT M 16/M4 DRAWER	
1*	NOT ASSIGNED	1NSG3	15500104-001	.M16/M4 RIFLE DRAWER GREEN	AR
2	NOT ASSIGNED	1NSG3	16035063	.. M16/M4 MUZZLE BLOCK ASSEMBLY	1
3	NOT ASSIGNED	1NSG3	15981873	...MUZZLE BLOCK HARDWARE KIT	2
4	NOT ASSIGNED	1NSG3	16035056-001	M16/M4 CENTER BLOCKS ASSEMBLY GREEN	1
5	NOT ASSIGNED	1NSG3	15988734	..LOCK ARM SPRINGS W/GUARDS	2
6	NOT ASSIGNED	1NSG3	15988733-001	.. LOCK ARM ASSEMBLY GREEN	1
7	NOT ASSIGNED	1NSG3	15981873-001	... LOCK ARM SLAM LATCH HARDWARE KIT GREEN	1
8	NOT ASSIGNED	1NSG3	15988720	..DRAWER LATCH PIN KIT	1
1*	NOT ASSIGNED	1NSG3	15500104-002	.M16/M4 RIFLE DRAWER TAN	AR
2	NOT ASSIGNED	1NSG3	16035063	.. M16/M4 MUZZLE BLOCK ASSEMBLY	1
3	NOT ASSIGNED	1NSG3	15981873	...MUZZLE BLOCK HARDWARE KIT	2
4	NOT ASSIGNED	1NSG3	16035056-002	M16/M4 CENTER BLOCKS ASSEMBLY TAN	1
5	NOT ASSIGNED	1NSG3	15988734	..LOCK ARM SPRINGS W/GUARDS	2
6	NOT ASSIGNED	1NSG3	15988733-002	.. LOCK ARM ASSEMBLY TAN	1
7	NOT ASSIGNED	1NSG3	15981873-002	... LOCK ARM SLAM LATCH HARDWARE KIT TAN	1
8	NOT ASSIGNED	1NSG3	15988720	..DRAWER LATCH PIN KIT	1
END OF FIGURE 35					

NOTE

*Drawer slides included with module hull.

BULK DRAWER 8"
Door removed for clarity

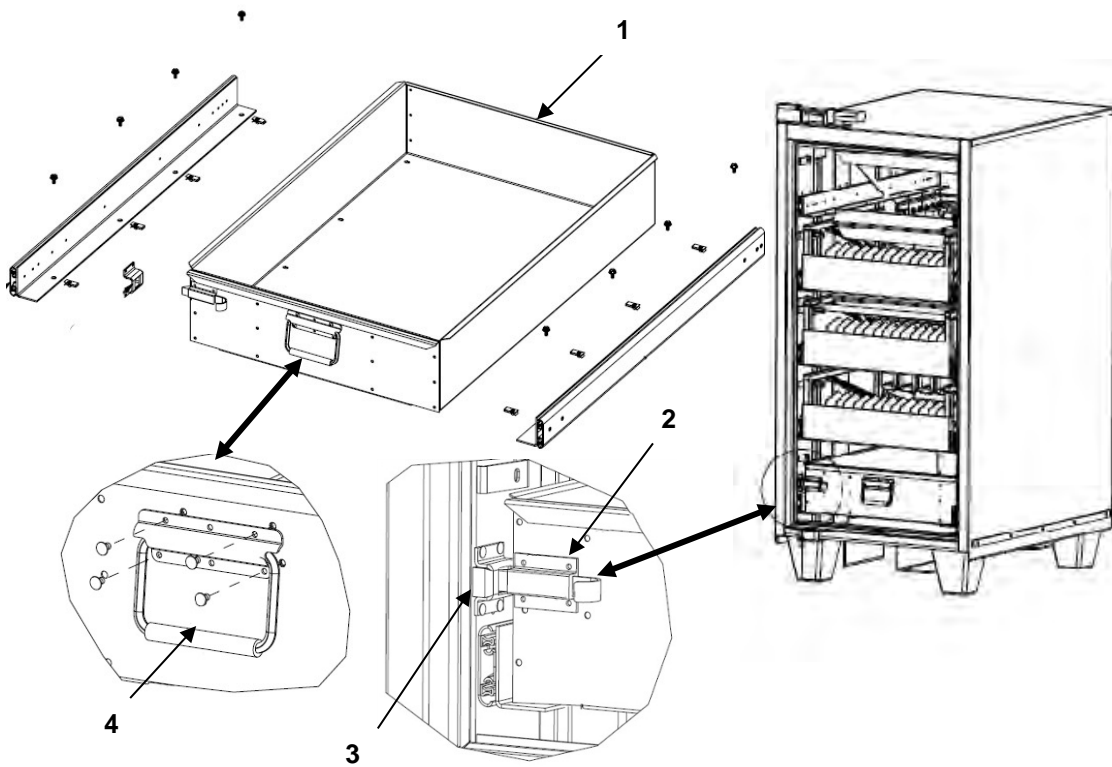

FIGURE 36 BULK DRAWER 8"

(1) ITEM NO.	(2) NSN	(3) CAGEC	(4) PART NUMBER	(5) DESCRIPTION AND USABLE ON CODE (UOC)	(6) QTY
				GROUP 020206 FIGURE 36 BULK DRAWER 8"	
1*	8145-01-528-2853	1NSG3	15520860-001	.BULK DRAWER 8" GREEN	AR
2	NOT ASSIGNED	1NSG3	74100502	..SLAM LATCH	1
3	NOT ASSIGNED	1NSG3	16130004	..STRIKER PLATE	1
4	NOT ASSIGNED	1NSG3	74090520	..DRAWER HANDLE	1
1*	8145-01-528-2853	1NSG3	15520860-002	.BULK DRAWER 8" TAN	AR
2	NOT ASSIGNED	1NSG3	74100502	..SLAM LATCH	1
3	NOT ASSIGNED	1NSG3	16130004	..STRIKER PLATE	1
4	NOT ASSIGNED	1NSG3	74090520	..DRAWER HANDLE	1
END OF FIGURE 36					

NOTE

*Drawer slides included with module hull.

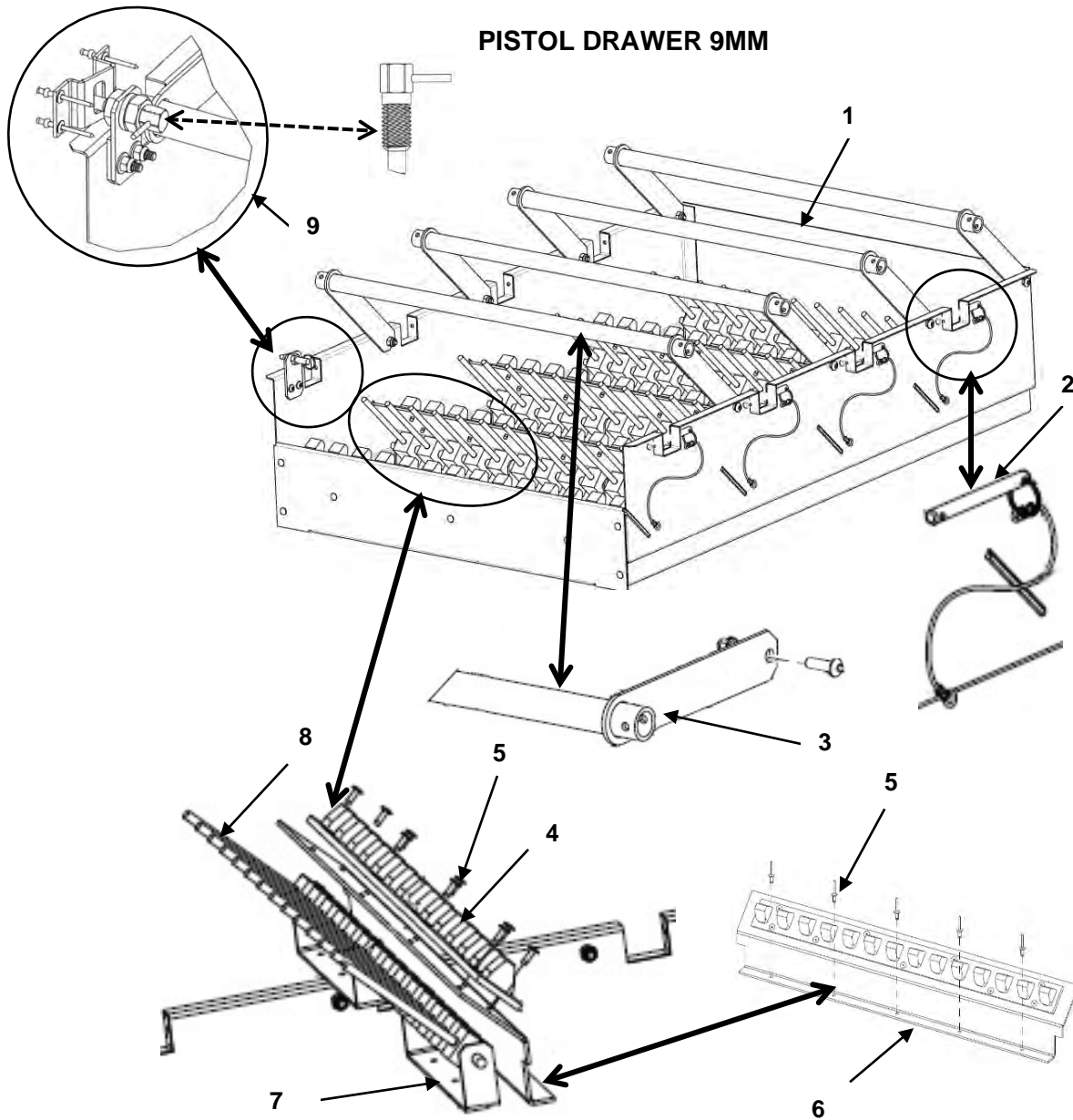

FIGURE 37 PISTOL DRAWER 9MM

(1) ITEM NO.	(2) NSN	(3) CAGEC	(4) PART NUMBER	(5) DESCRIPTION AND USABLE ON CODE (UOC)	(6) QTY
				GROUP 020207 FIGURE 37 PISTOL DRAWER 9MM	
1*	8145-01-502-2611	1NSG3	15500102-001	.PISTOL DRAWER, 9MM GREEN	AR
2	NOT ASSIGNED	1NSG3	15988723	.. SECURING PINS, W/LANYARD	8
3	NOT ASSIGNED	1NSG3	15988722	..PISTOL LOCK ARM ASSEMBLY	4
4	NOT ASSIGNED	1NSG3	15080131	..9MM BASE PLUG GANG OF 14	1
5	NOT ASSIGNED	1NSG3	15640322	...POP RIVETS 3/16	9
6	NOT ASSIGNED	1NSG3	16090005	...PISTOL BUTT SUPPORT PLATE	1
5	NOT ASSIGNED	1NSG3	15640322	...POP RIVETS 3/16	5
7	NOT ASSIGNED	1NSG3	16090002	...BARREL ROD BRACKET	2
8	NOT ASSIGNED	1NSG3	15981888	...BARREL ROD	14
9	NOT ASSIGNED	1NSG3	15988724	..DRAWER LATCH PIN KIT	1
1*	8145-01-502-2611	1NSG3	15500102-002	.PISTOL DRAWER, 9MM TAN	AR
2	NOT ASSIGNED	1NSG3	15988723	.. SECURING PINS, W/LANYARD	8
3	NOT ASSIGNED	1NSG3	15988722	..PISTOL LOCK ARM ASSEMBLY	4
4	NOT ASSIGNED	1NSG3	15080131	..9MM BASE PLUG GANG OF 14	1
5	NOT ASSIGNED	1NSG3	15640322	...POP RIVETS 3/16	9
6	NOT ASSIGNED	1NSG3	16090005	...PISTOL BUTT SUPPORT PLATE	1
5	NOT ASSIGNED	1NSG3	15640322	...POP RIVETS 3/16	5
7	NOT ASSIGNED	1NSG3	16090002	...BARREL ROD BRACKET	2
8	NOT ASSIGNED	1NSG3	15981888	...BARREL ROD	14
9	NOT ASSIGNED	1NSG3	15988724	..DRAWER LATCH PIN KIT	1
END OF FIGURE 37					

NOTE

*Drawer slides included with module hull.

END OF WORK PACKAGE**0036 00-19**

This page was intentionally left blank

PARTS SUPPORTING INFORMATION

**FPU SYSTEMS OPERATION MANUAL
(INCLUDING REPAIR PARTS & SPECIAL TOOL LIST)
STANDARD AND SPECIALIZED FPU MODULES
BOH FPU Field Pack-up Units**

SPECIALIZED MODULES

FLAMMABLE/CORROSIVE MODULE

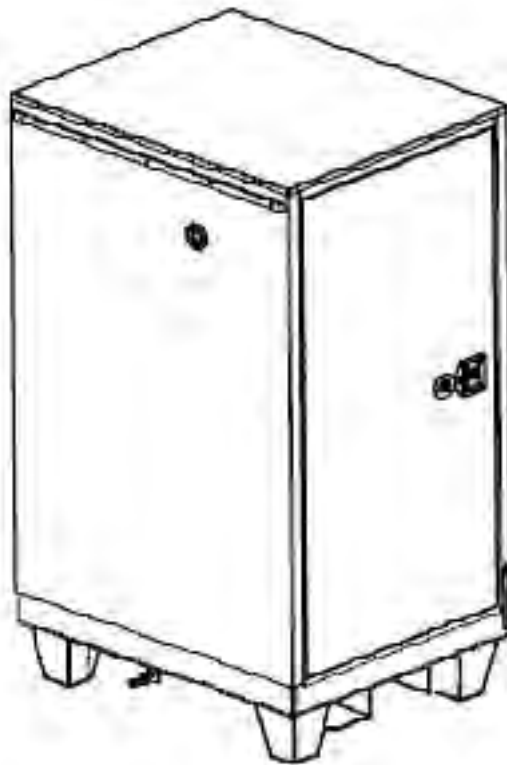

FIGURE #38 Through #42

FLAMMABLE/CORROSIVE MODULE

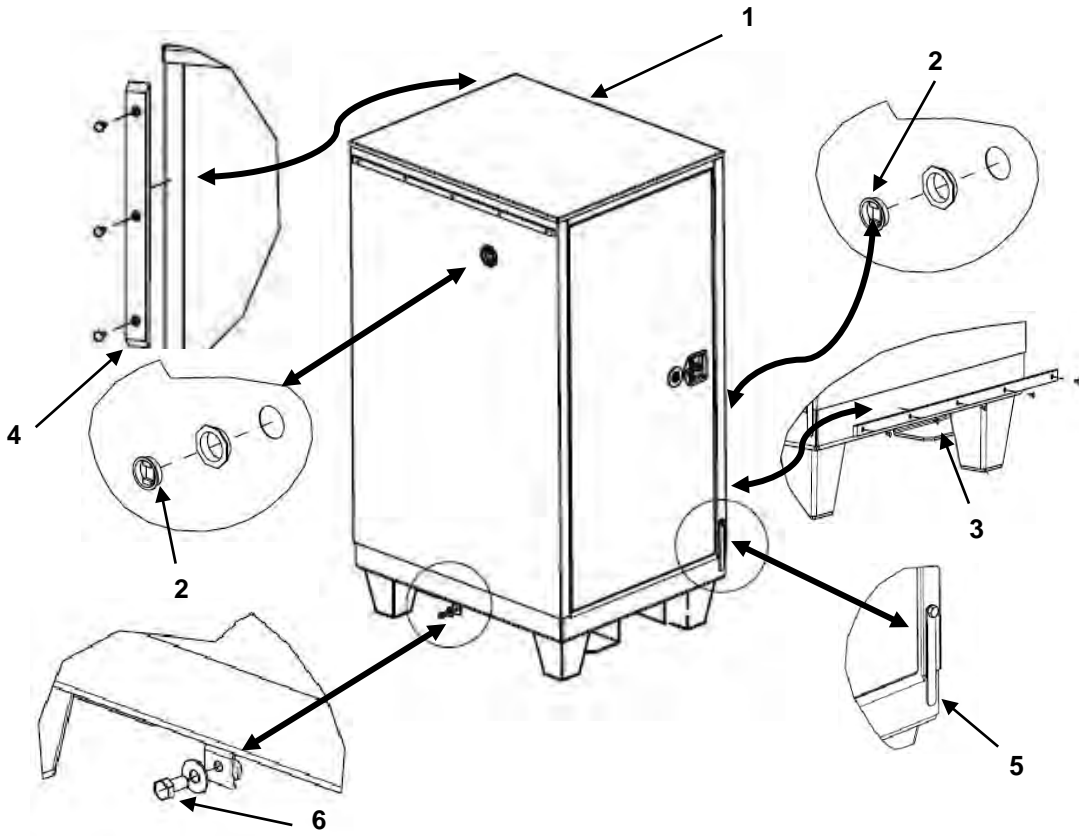

FIGURE 38 FLAMMABLE MODULE

(1) ITEM NO.	(2) NSN	(3) CAGEC	(4) PART NUMBER	(5) DESCRIPTION AND USABLE ON CODE (UOC)	(6) QTY
				GROUP 0203 FIGURE 38 FLAMMABLE/CORROSIVE MODULE	
1	8145-01-502-2611	1NSG3	15500101-001	.FLAMMABLE/CORROSIVE MODULE GREEN	1
2	NOT ASSIGNED	1NSG3	80760232	..VENT CAPS	2
3	NOT ASSIGNED	1NSG3	16011031	..SIDE RUB STRIPS	2
4	NOT ASSIGNED	1NSG3	16011032	..REAR RUB STRIP	1
5	NOT ASSIGNED	1NSG3	15988596	..GROUND STRAP W HDWR	1
6	NOT ASSIGNED	1NSG3	15988595- 001	..GROUND LUG KIT GREEN	1
1	8145-01-473-1288	1NSG3	15500101-002	. FLAMMABLE/CORROSIVE MODULE TAN	1
2	NOT ASSIGNED	1NSG3	80760232	..VENT CAPS	2
3	NOT ASSIGNED	1NSG3	16011031	..SIDE RUB STRIPS	2
4	NOT ASSIGNED	1NSG3	16011032	..REAR RUB STRIP	1
5	NOT ASSIGNED	1NSG3	15988596	..GROUND STRAP W HDWR	1
6	NOT ASSIGNED	1NSG3	15988595- 002	..GROUND LUG KIT TAN	1
END OF FIGURE 38					

FLAMMABLE/CORROSIVE DOOR ASSEMBLY

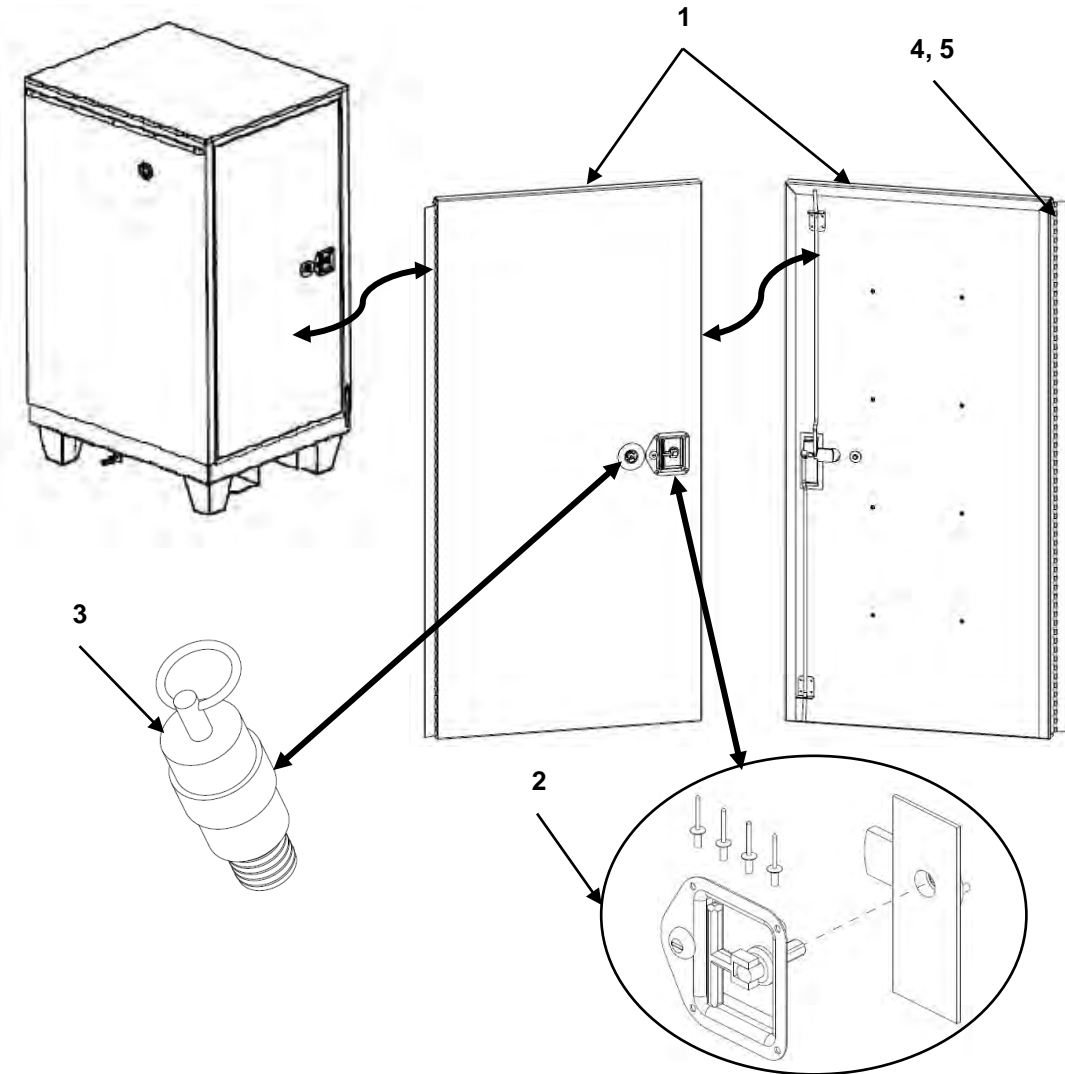

FIGURE 39 FLAMMABLE/CORROSIVE DOOR ASSEMBLY

(1) ITEM NO.	(2) NSN	(3) CAGEC	(4) PART NUMBER	(5) DESCRIPTION AND USABLE ON CODE (UOC)	(6) QTY
				GROUP 020301 FIGURE 39 FLAMMABLE/CORROSIVE DOOR ASSEMBLY	
1	NOT ASSIGNED	1NSG3	16011065-001	.FLAM LOCKER DOOR W/ HINGE, LATCH AND HARDWARE GREEN	1
2	NOT ASSIGNED	1NSG3	15988588	..DOOR HANDLE KIT W/THREE POINT DEAD BOLT	1
3	NOT ASSIGNED	1NSG3	15172034	..PRESSURE RELIEF VALVE BRASS	1
4	NOT ASSIGNED	1NSG3	16011070	..DOOR HINGE	1
5	NOT ASSIGNED	1NSG3	16011040	..DOOR HINGE SHIM	1
1	NOT ASSIGNED	1NSG3	16011065-002	.FLAM LOCKER DOOR W/ HINGE, LATCH AND HARDWARE TAN	1
2	NOT ASSIGNED	1NSG3	15988588	..DOOR HANDLE KIT W/THREE POINT DEAD BOLT	1
3	NOT ASSIGNED	1NSG3	15172034	..PRESSURE RELIEF VALVE BRASS	1
4	NOT ASSIGNED	1NSG3	16011070	..DOOR HINGE	1
5	NOT ASSIGNED	1NSG3	16011040	..DOOR HINGE SHIM	1
END OF FIGURE 39					

FLAMMABLE/CORROSIVE MODULE DOOR SEALS and RETAINING BAR
Door removed for clarity

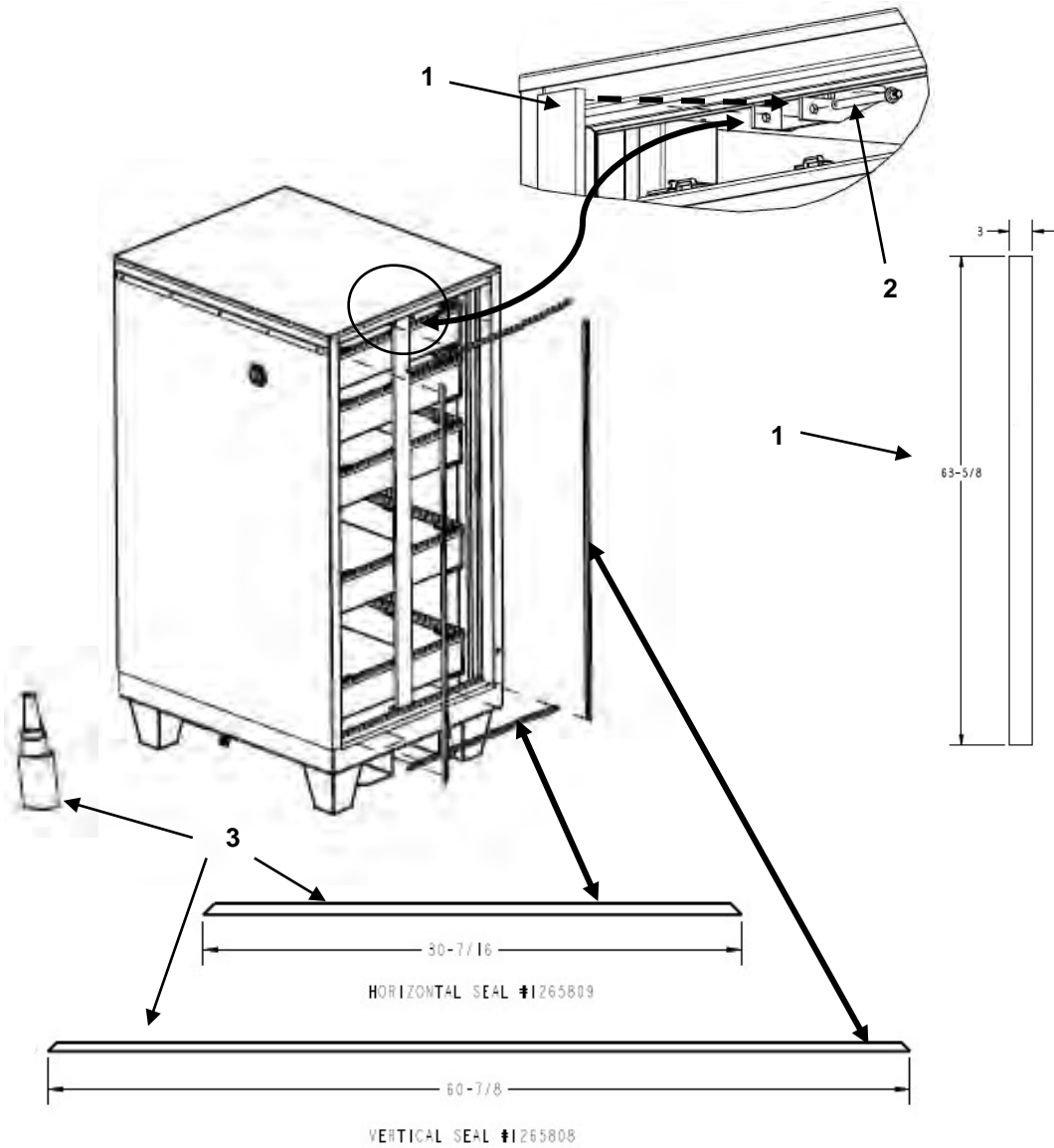

FIGURE 40 FLAMMABLE/CORROSIVE MODULE DOOR SEALS and RETAINING BAR

(1) ITEM NO.	(2) NSN	(3) CAGEC	(4) PART NUMBER	(5) DESCRIPTION AND USABLE ON CODE (UOC)	(6) QTY
				GROUP 020302 FIGURE 40 DOOR SEALS and RETAINING BAR	
1	NOT ASSIGNED	1NSG3	16011024-001	RETAINING BAR GREEN	1
2	NOT ASSIGNED	1NSG3	15988599	.RETAINING BAR PIN WITH LANYARD	1
3	NOT ASSIGNED	1NSG3	15988700	.DOOR GASKET KIT W ADHESIVE	1
1	NOT ASSIGNED	1NSG3	16011024-002	RETAINING BAR TAN	1
2	NOT ASSIGNED	1NSG3	15988599	.RETAINING BAR PIN WITH LANYARD	1
3	NOT ASSIGNED	1NSG3	15988700	.DOOR GASKET KIT W ADHESIVE	1
END OF FIGURE 40					

DRAWERS SLIDES AND NETS

Door removed for clarity

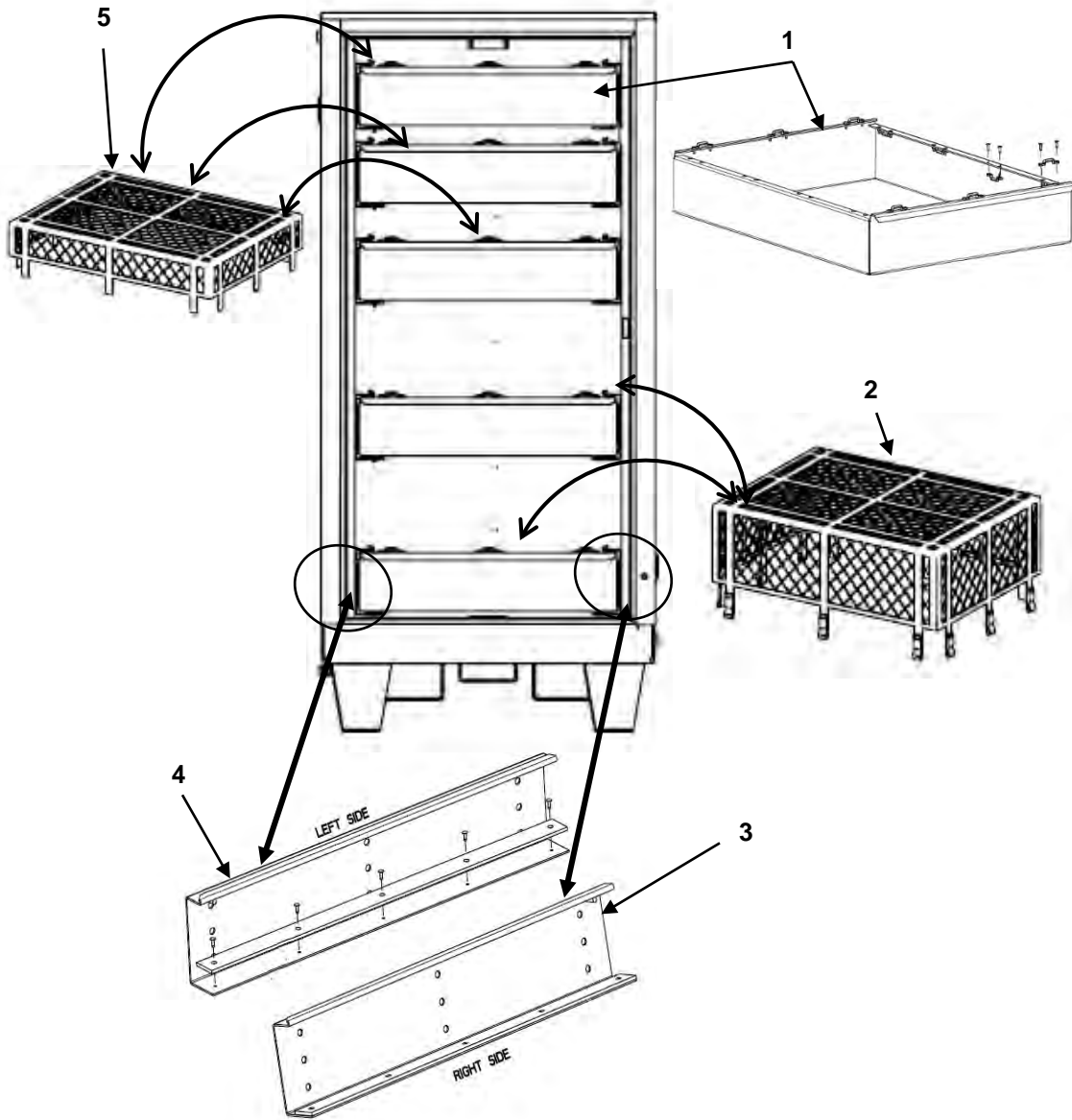

FIGURE 41 DRAWERS SLIDES AND NETS

(1) ITEM NO.	(2) NSN	(3) CAGEC	(4) PART NUMBER	(5) DESCRIPTION AND USABLE ON CODE (UOC)	(6) QTY
				GROUP 020303 FIGURE 41 DRAWER, SLIDES AND NETS	
1	NOT ASSIGNED	1NSG3	16011054-001	.DRAWER ASSEMBLY GREEN	5
2	NOT ASSIGNED	1NSG3	15522024	..NET LARGE	2
3	NOT ASSIGNED	1NSG3	15988591-001	..DRAWER SLIDES ASSEMBLY RIGHT GREEN	5
4	NOT ASSIGNED	1NSG3	15988590-001	..DRAWER SLIDES ASSEMBLY LEFT GREEN	5
5	NOT ASSIGNED	1NSG3	15522022	..NET SMALL	3
1	NOT ASSIGNED	1NSG3	16011054-002	.DRAWER ASSEMBLY GREEN	5
2	NOT ASSIGNED	1NSG3	15522024	..NET LARGE	2
3	NOT ASSIGNED	1NSG3	15988591-002	..DRAWER SLIDES RIGHT TAN	5
4	NOT ASSIGNED	1NSG3	15988590-002	..DRAWER SLIDES LEFT TAN	5
5	NOT ASSIGNED	1NSG3	15522022	..NET SMALL	3
END OF FIGURE 41					

END OF WORK PACKAGE

Standard/Specialized Module Casters

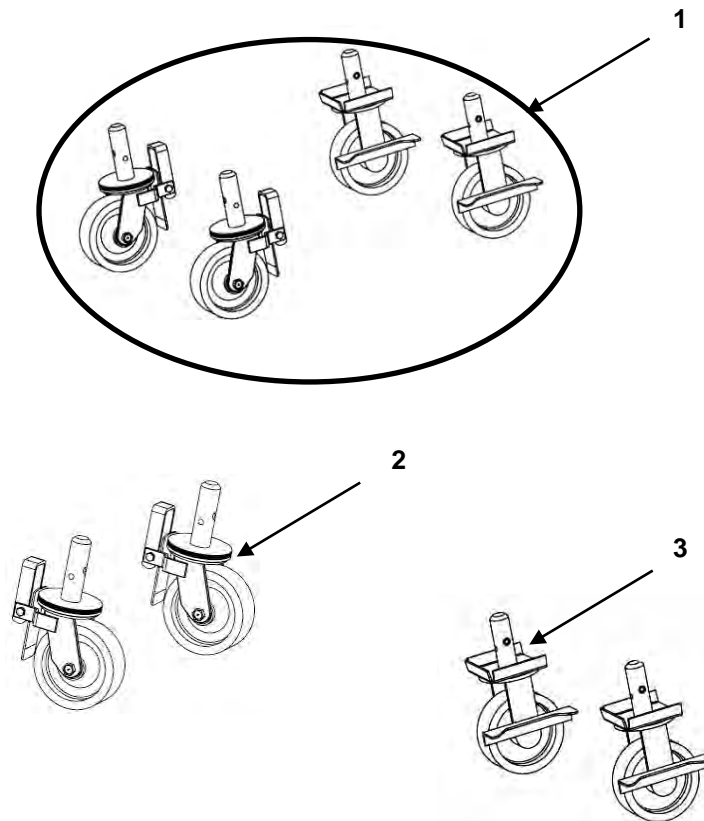

Figure 42 Standard/Specialized Module Casters

(1) ITEM NO.	(2) NSN	(3) CAGEC	(4) PART NUMBER	(5) DESCRIPTION AND USABLE ON CODE (UOC)	(6) QTY
				GROUP 020304 FIGURE 42 Standard/Specialized Module Casters	
1	NOT ASSIGNED	1NSG3	15510000	.CASTER SET	1
2	NOT ASSIGNED	1NSG3	15510101	..CASTERS FRONT SWIVEL	2
3	NOT ASSIGNED	1NSG3	15510102	..CASTERS REAR RIGID	2
END OF FIGURE 42					

NOTE

The rigid casters are no longer available as of February 2017. A module caster set will now include four swivel casters.

This page was intentionally left blank

PARTS SUPPORTING INFORMATION

**FPU SYSTEMS OPERATION MANUAL
(INCLUDING REPAIR PARTS & SPECIAL TOOL LIST)
STANDARD AND SPECIALIZED FPU MODULES
BOH FPU Field Pack-up Units**

FPU BULK MODULES

FPU BULK MODULES #1 through #4

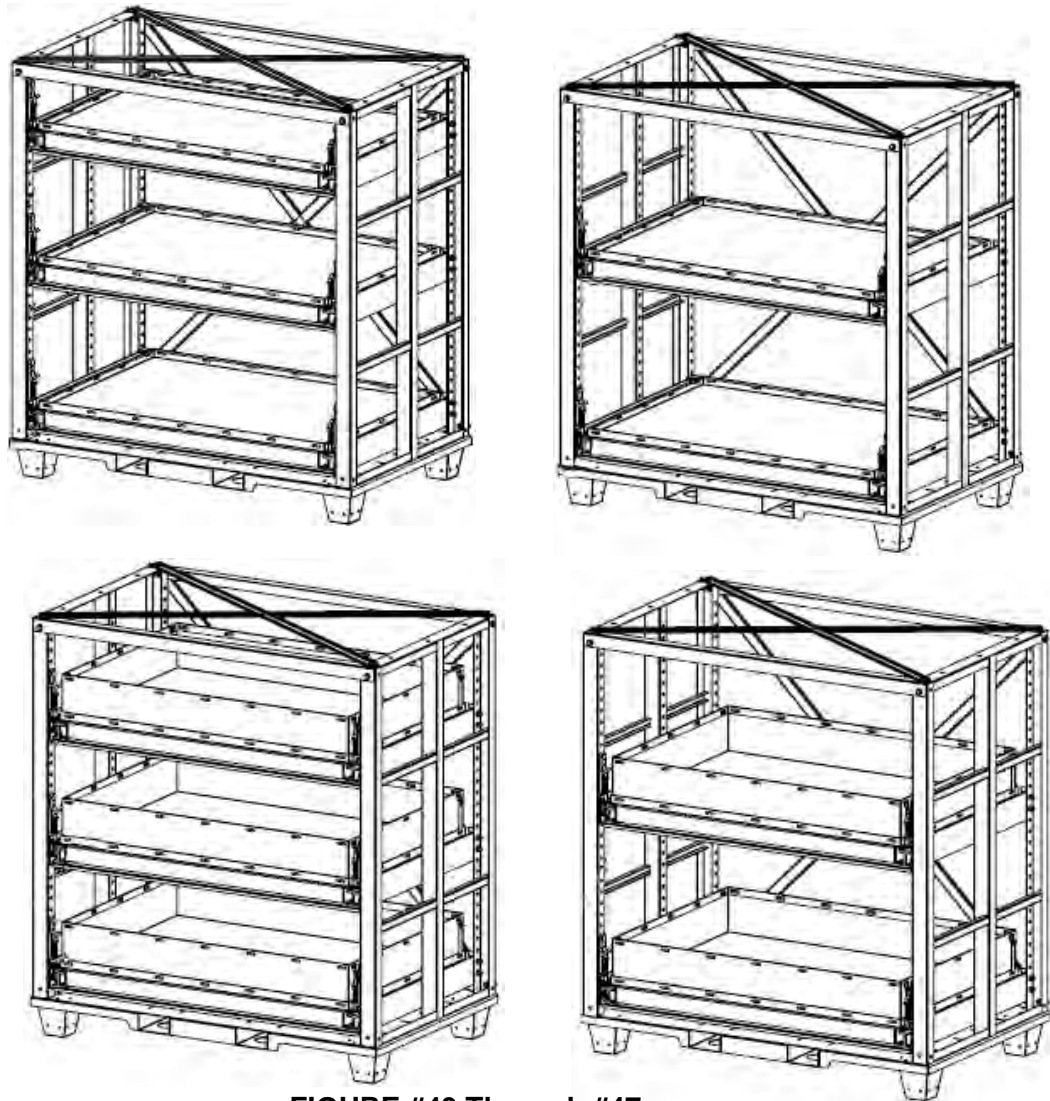

FIGURE #43 Through #47

0038 00-1

FPU BULK MODULES

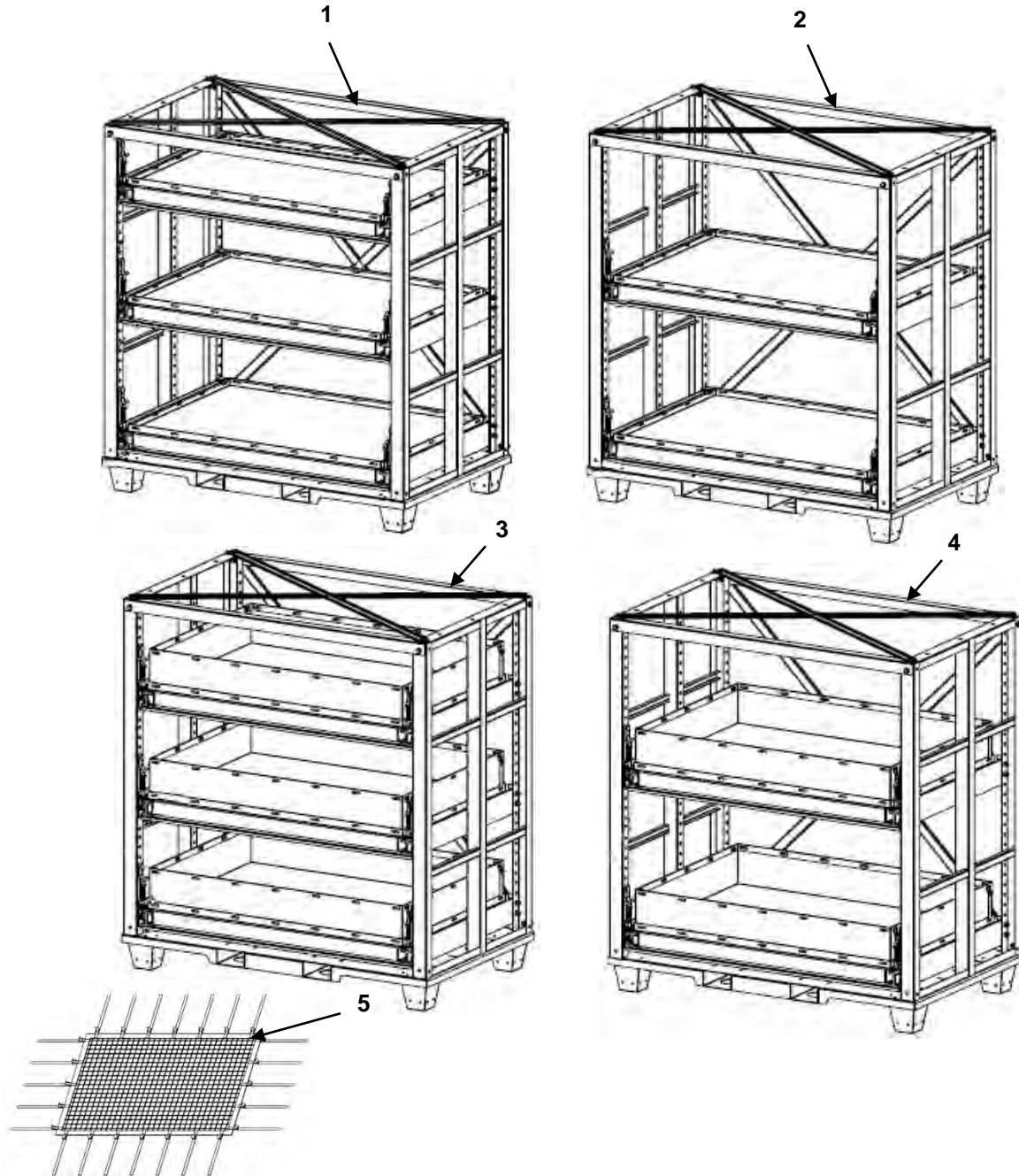

FIGURE 43 FPU BULK MODULES

ITEM NO.	(2) NSN	(3) CAGEC	(4) PART NUMBER	(5) DESCRIPTION AND USABLE ON CODE (UOC)	(6) QTY
				GROUP 0204 FIGURE 43 BULK STORAGE/SHIPPING MODULE	
1	8145-01-588-3689	1NSG3	15410201-001	.THREE TRAY BULK MODULE GREEN	1
5	NOT ASSIGNED	1NSG3	15410079	..NET	3
1	8145-01-588-3689	1NSG3	15410201-002	.THREE TRAY BULK MODULE TAN	1
5	NOT ASSIGNED	1NSG3	15410079	..NET	3
2	8145-01-588-3690	1NSG3	15410202-001	.TWO TRAY BULK MODULE GREEN	1
5	NOT ASSIGNED	1NSG3	15410079	..NET	2
2	8145-01-588-3690	1NSG3	15410202-002	.TWO TRAY BULK MODULE TAN	1
5	NOT ASSIGNED	1NSG3	15410079	..NET	2
3	8145-01-588-3691	INSG3	15410203-001	.THREE BIN BULK MODULE WITH BATTERY 8" TRAYS GREEN	1
5	NOT ASSIGNED	1NSG3	15410079	..NET	3
3	8145-01-588-3691	1NSG3	15410203-002	.THREE BIN BULK MODULE WITH BATTERY 8" TRAYS TAN	1
5	NOT ASSIGNED	1NSG3	15410079	..NET	3
4	8145-01-588-3692	1NSG3	15410204-001	.TWO BIN BULK MODULE WITH BATTERY TRAYS 8" GREEN	1
5	NOT ASSIGNED	1NSG3	15410079	..NET	2
4	8145-01-588-3692	1NSG3	15410204-002	.TWO BIN BULK MODULE WITH BATTERY TRAYS 8" TAN	1
5	NOT ASSIGNED	1NSG3	15410079	..NET	2
END OF FIGURE 43					

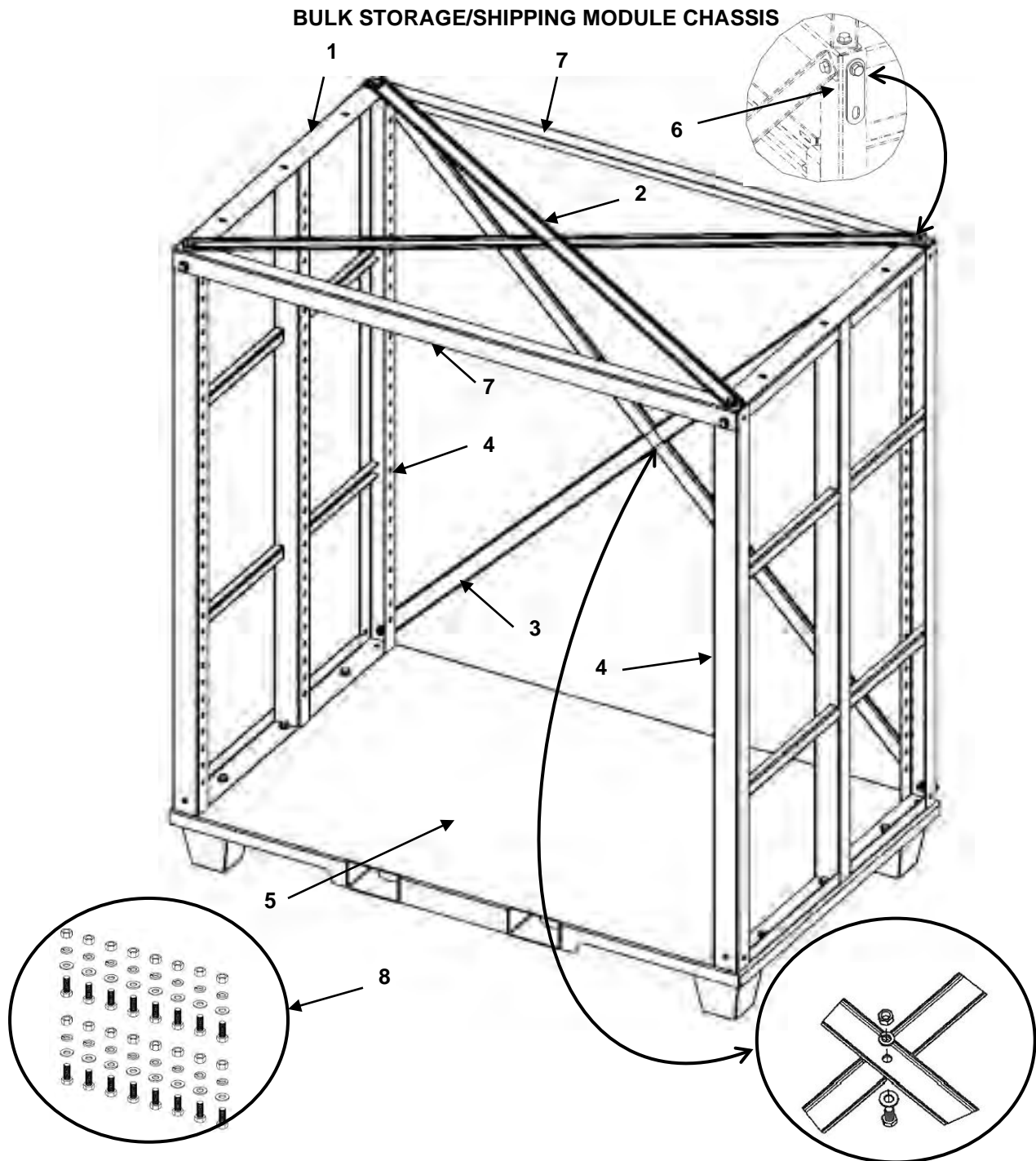

FIGURE 44 BULK STORAGE/SHIPPING MODULE CHASSIS

(1) ITEM NO.	(2) NSN	(3) CAGEC	(4) PART NUMBER	(5) DESCRIPTION AND USABLE ON CODE (UOC)	(6) QTY
				GROUP 020401 FIGURE 44 BULK STORAGE/SHIPPING MODULE CHASSIS	
1	NOT ASSIGNED	1NSG3	15410001-001	.FPU BULK CHASSIS ASSY GREEN	1
1	NOT ASSIGNED	1NSG3	15410001-002	.FPU BULK CHASSIS ASSY TAN	1
2	NOT ASSIGNED	1NSG3	15988913-001	..CROSS BARS TOP W/HDWR GREEN	1
2	NOT ASSIGNED	1NSG3	15988913-002	..CROSS BARS TOP W/HDWR TAN	1
3	NOT ASSIGNED	1NSG3	15988914-001	..CROSS BARS REAR W/HDWR GREEN	1
3	NOT ASSIGNED	1NSG3	15988914-002	..CROSS BARS REAR W/HDWR TAN	1
4	NOT ASSIGNED	1NSG3	15988905-001	..SIDE FRAME W/HDWR GREEN	2
4	NOT ASSIGNED	1NSG3	15988905-002	..SIDE FRAME W/HDWR TAN	2
5	NOT ASSIGNED	1NSG3	15410026-001	..BASE GREEN	1
5	NOT ASSIGNED	1NSG3	15410026-002	..BASE TAN	1
6	NOT ASSIGNED	1NSG3	15988912-001	..REAR SECURING BRACKET W/HDWR GREEN	1
6	NOT ASSIGNED	1NSG3	15988912-002	..REAR SECURING BRACKET W/HDWR TAN	1
7	NOT ASSIGNED	1NSG3	15988938-001	..CROSS BRACE F/R GREEN	2
7	NOT ASSIGNED	1NSG3	15988938-002	..CROSS BRACE F/R TAN	2
8	NOT ASSIGNED	1NSG3	15988906	...CHASSIS HARDWARE KIT	1
END OF FIGURE 44					

BULK TRAY 1000 lb.

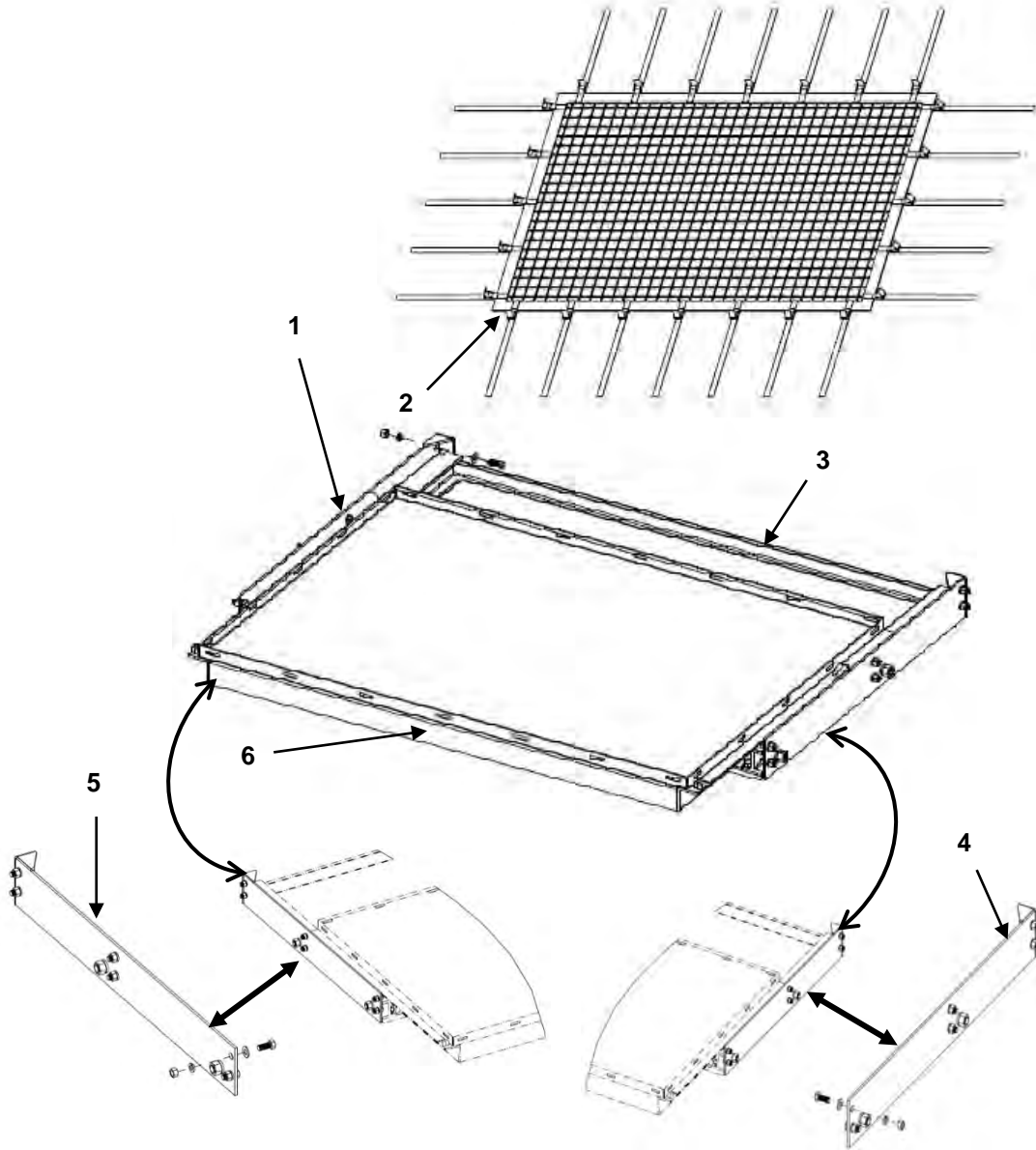

FIGURE 45 BULK TRAY 1000 lb.

(1) ITEM NO.	(2) NSN	(3) CAGEC	(4) PART NUMBER	(5) DESCRIPTION AND USABLE ON CODE (UOC)	(6) QTY
				GROUP 020402 FIGURE 45 BULK TRAY 1000 lb.	
1	NOT ASSIGNED	1NSG3	15988910-001	.TRAY ASSEMBLY 1000 lb. COMPLETE W/HDWR GREEN	1
2	NOT ASSIGNED	1NSG3	15410079	..NET	1
1	NOT ASSIGNED	1NSG3	15988910-002	.TRAY ASSEMBLY 1000 lb. COMPLETE W/HDWR TAN	1
2	NOT ASSIGNED	1NSG3	15410079	..NET	1
3	NOT ASSIGNED	1NSG3	15410083	.. INTERMEDIATE DRAWER SLIDE ASSY W/HDWR	1
4	NOT ASSIGNED	1NSG3	15988907-001	... SLIDE ASSY RIGHT GREEN	1
4	NOT ASSIGNED	1NSG3	15988907-002	... SLIDE ASSY RIGHT TAN	1
5	NOT ASSIGNED	1NSG3	15988908-001	... SLIDE ASSY LEFT GREEN	1
5	NOT ASSIGNED	1NSG3	15988908-002	... SLIDE ASSY LEFT TAN	1
6	NOT ASSIGNED	1NSG3	15410085	... TRAY ONLY	1
END OF FIGURE 45					

8" BULK BIN ADAPTER KIT

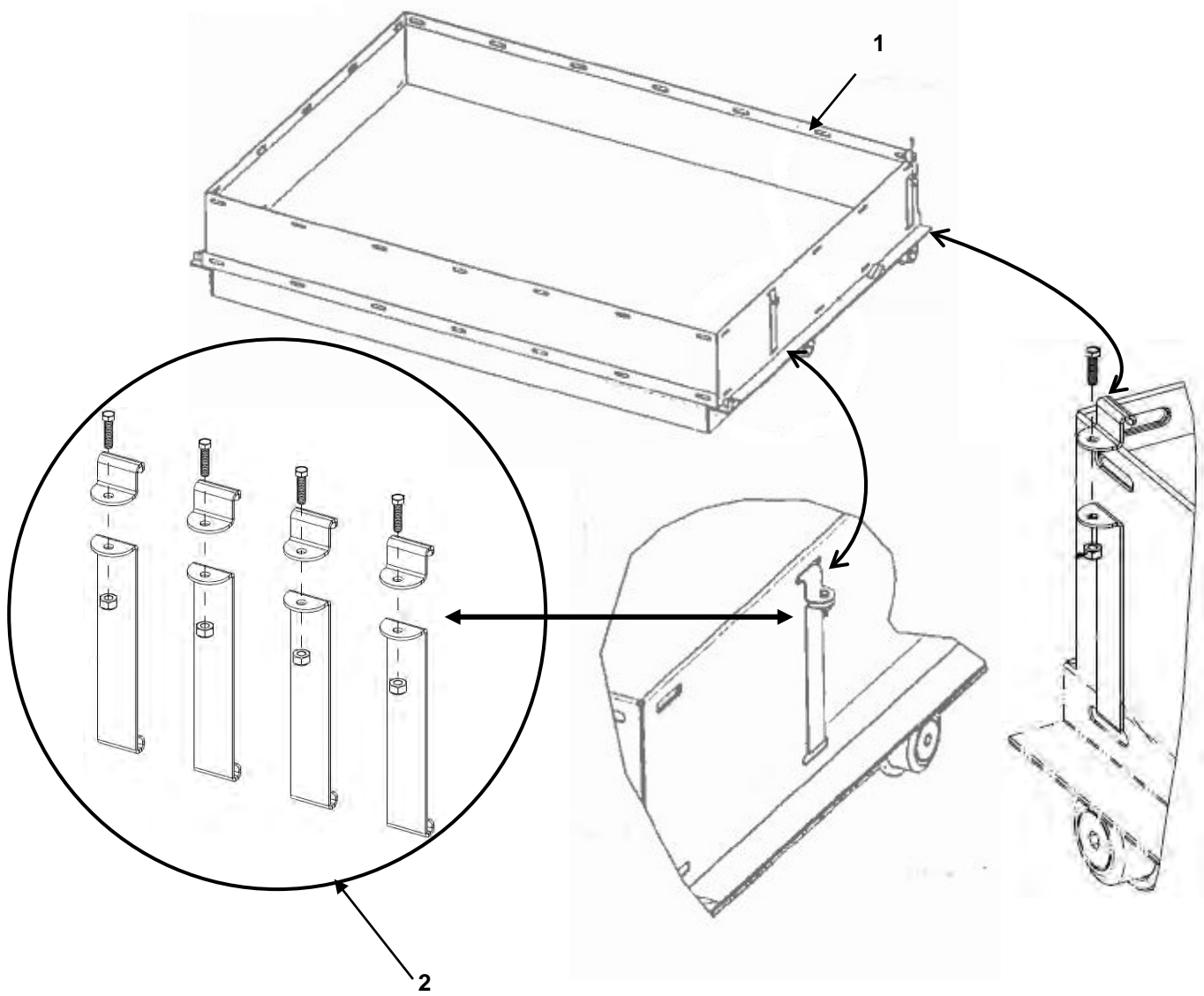

FIGURE 46 BULK 8" BIN ADAPTER KIT

(1) ITEM NO.	(2) NSN	(3) CAGEC	(4) PART NUMBER	(5) DESCRIPTION AND USABLE ON CODE (UOC)	(6) QTY
				GROUP 020403 FIGURE 46 BULK 8" BIN ADAPTER KIT	
1	NOT ASSIGNED	1NSG3	15988919-001	. BIN ADAPTER KIT 8" W/HDWR GREEN	1
1	NOT ASSIGNED	1NSG3	15988919-002	. BIN ADAPTER KIT 8" W/HDWR TAN	1
2	NOT ASSIGNED	1NSG3	15988920	..8 " BIN KIT CLIPS W/HDWR	1
END OF FIGURE 46					

LATCH AND BEARING ASSEMBLIES

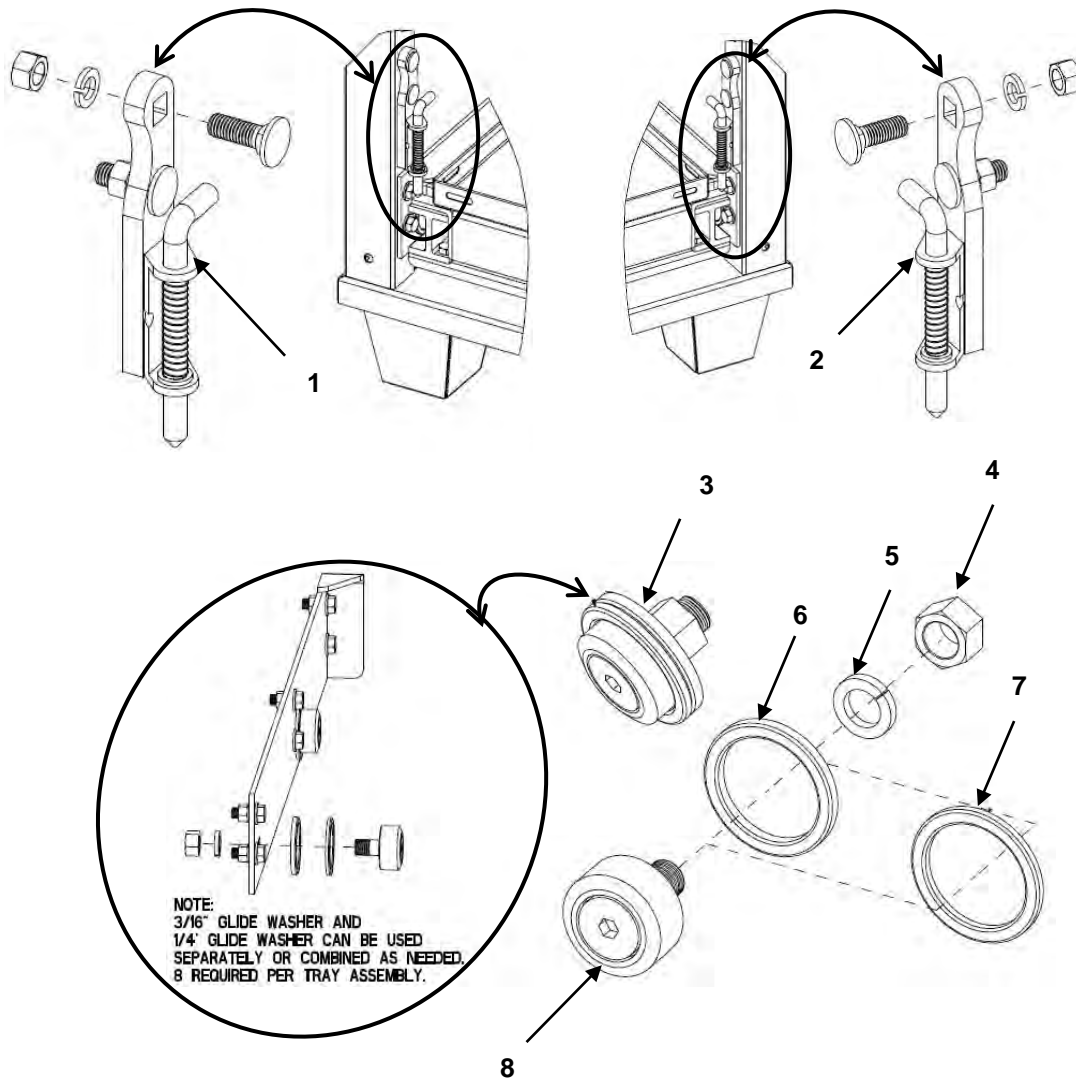

FIGURE 47 LATCH AND BEARING ASSEMBLIES

(1) ITEM NO.	(2) NSN	(3) CAGEC	(4) PART NUMBER	(5) DESCRIPTION AND USABLE ON CODE (UOC)	(6) QTY
				GROUP 020404 FIGURE 47 LATCH AND BEARING ASSEMBLIES	
1	NOT ASSIGNED	1NSG3	15988916	. SHELF LATCH LEFT HAND	1
2	NOT ASSIGNED	1NSG3	15988915	. SHELF LATCH RIGHT HAND	1
3	NOT ASSIGNED	1NSG3	15988925	.ROLLER BEARING ASSY W/HDWR	4
4	NOT ASSIGNED	1NSG3	15988934	..HEX NUT	1
5	NOT ASSIGNED	1NSG3	15988933	..SPLIT WASHER	1
6	NOT ASSIGNED	1NSG3	15988937	..1/4 INCH WASHER	1
7	NOT ASSIGNED	1NSG3	15988936	..3/16 INCH WASHER	1
8	NOT ASSIGNED	1NSG3	15988935	..ROLLER BEARING	1
END OF FIGURE 47					

END OF WORK PACKAGE

This page was intentionally left blank

PARTS SUPPORTING INFORMATION

**FPU SYSTEMS OPERATION MANUAL
(INCLUDING REPAIR PARTS & SPECIAL TOOL LIST)
STANDARD AND SPECIALIZED FPU MODULES
BOH FPU Field Pack-up Units**

TRICON CONTAINER ADAPTER

TRICON CONTAINER ADAPTER

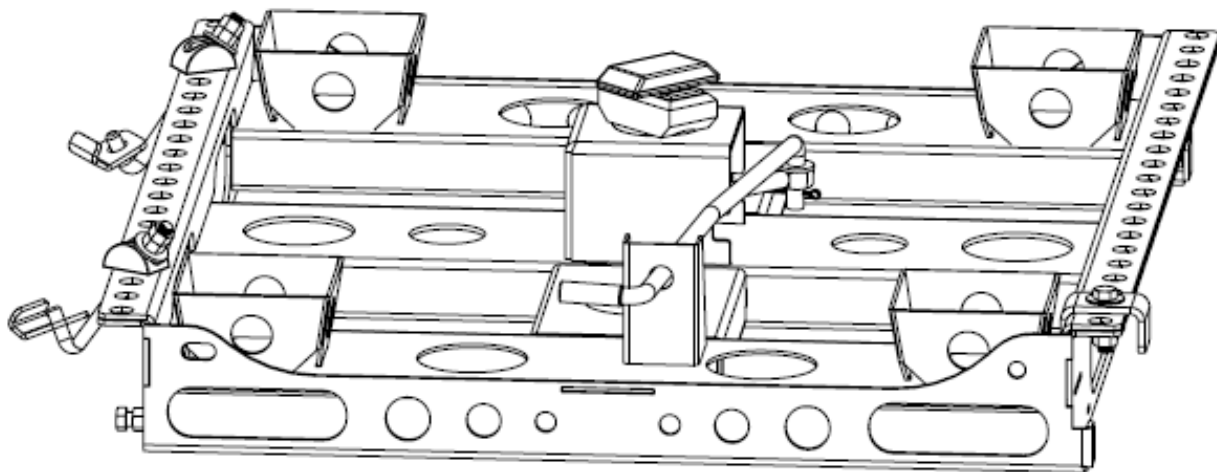

FIGURE #48 Through #59

TRICON ADAPTER

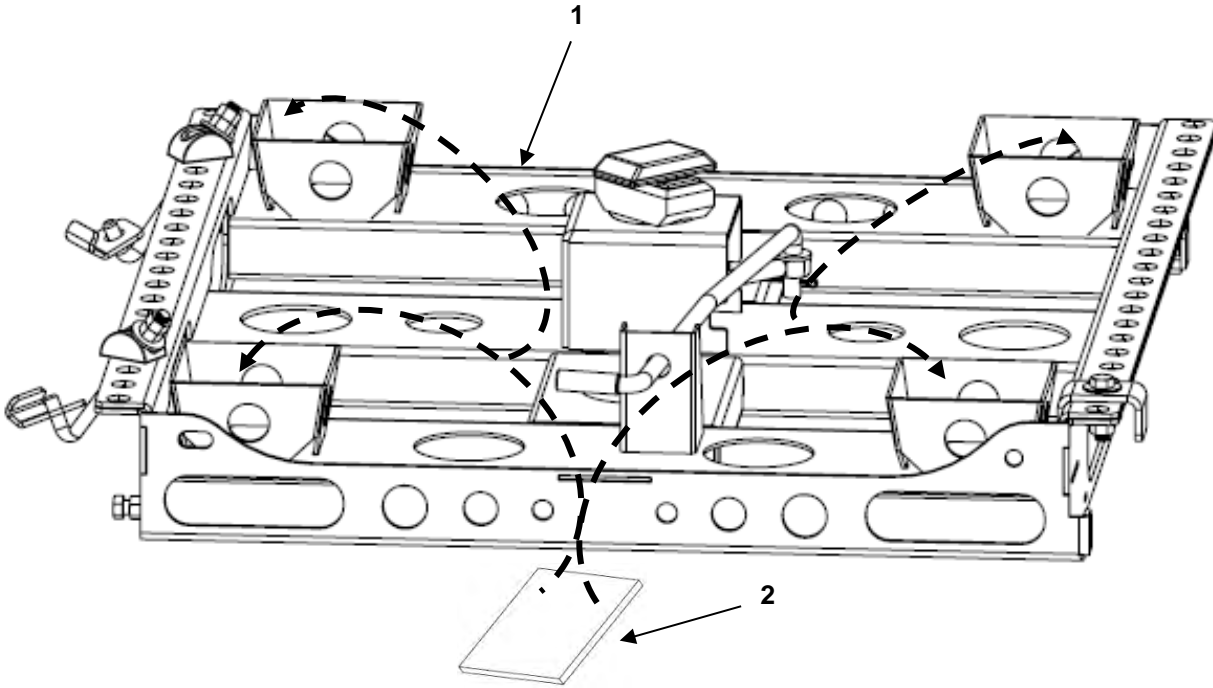

FIGURE 48 TRICON ADAPTER

(1) ITEM NO.	(3) NSN	(4) CAGEC	(5) PART NUMBER	(6) DESCRIPTION AND USABLE ON CODE (UOC)	(7) QTY
				GROUP 03 FIGURE 48 FPU TRICON ADAPTER	
1	8145-01-606-0505	1NSG3	15530128-001	.FPU TRICON ADAPTER WITH HARDWARE GREEN	1
1	8145-01-606-0505	1NSG3	15530128-002	.FPU TRICON ADAPTER WITH HARDWARE TAN	1
2	Not Assigned	1NSG3	16501304	..MODULE FOOT PAD	4
END OF FIGURE 48					

TRICON ADAPTER MOUNTING HARDWARE

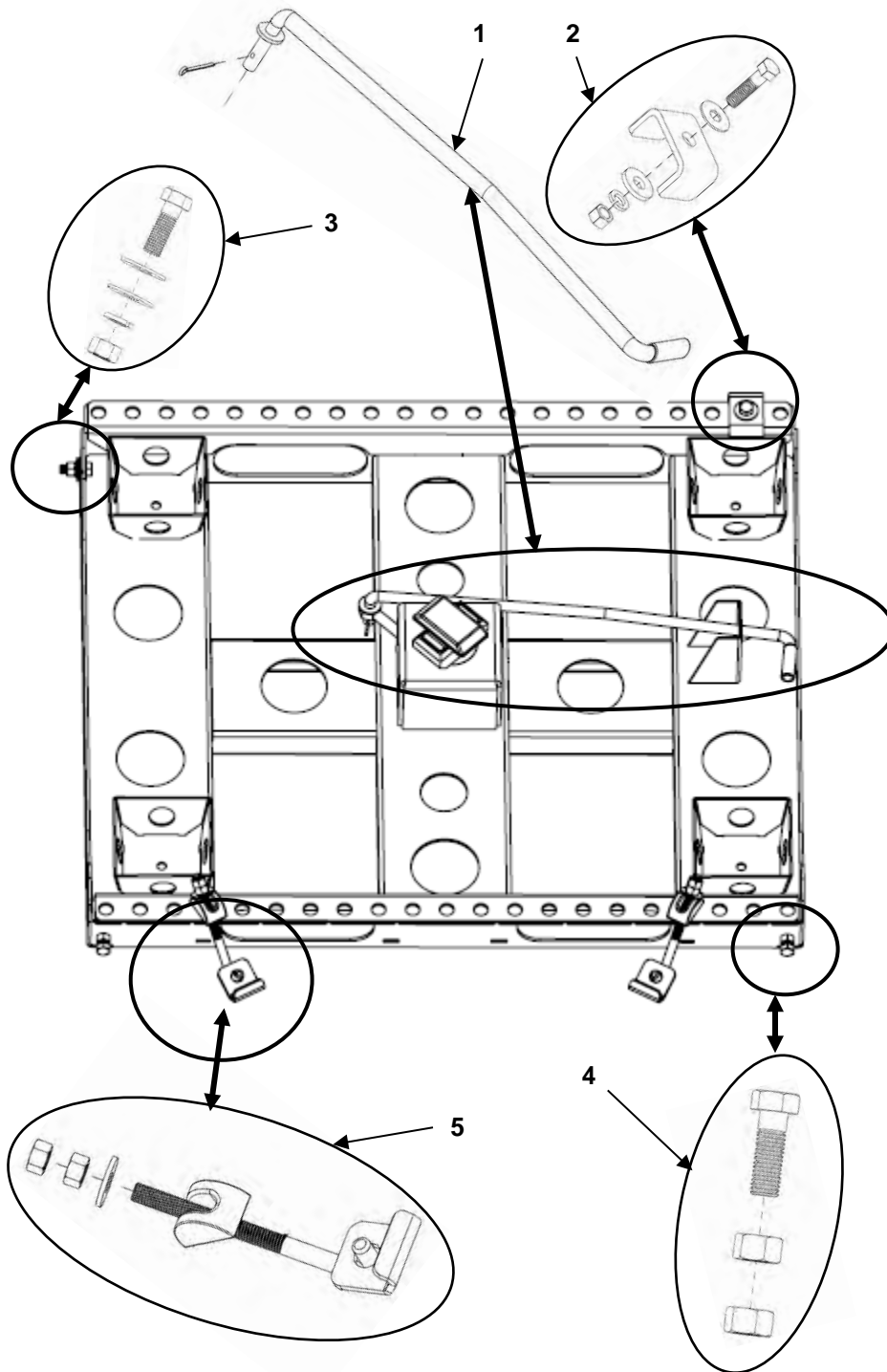

FIGURE 49 FPU TRICON ADAPTER LOCK HANDLE AND MOUNTING HARDWARE

(1) ITEM NO.	(3) NSN	(4) CAGEC	(5) PART NUMBER	(6) DESCRIPTION AND USABLE ON CODE (UOC)	(7) QTY
				GROUP 0301 FIGURE 49 TRICON ADAPTER LOCK HANDLE AND MOUNTING HARDWARE KITS	
1	Not Assigned	1NSG3	15988605-001	.MODULE LOCK HANDLE GREEN	1
1	Not Assigned	1NSG3	15988605-002	.MODULE LOCK HANDLE TAN	1
2	Not Assigned	1NSG3	15988924-001	.POSITIONER RETAINING PLATE KIT GREEN	1
2	Not Assigned	1NSG3	15988924-002	.POSITIONER RETAINING PLATE KIT TAN	1
3	Not Assigned	1NSG3	15988923	.REAR ADAPTER MOUNTING HARDWARE KIT	1
4	Not Assigned	1NSG3	15988922	.JACK BOLTS AND NUTS	2
5	Not Assigned	1NSG3	15988921-001	.HOOK BOLT HOOK PLATE KIT GREEN	2
5	Not Assigned	1NSG3	15988921-002	.HOOK BOLT HOOK PLATE KIT TAN	2
END OF FIGURE 49					

HOOK BOLT AND PLATE KIT

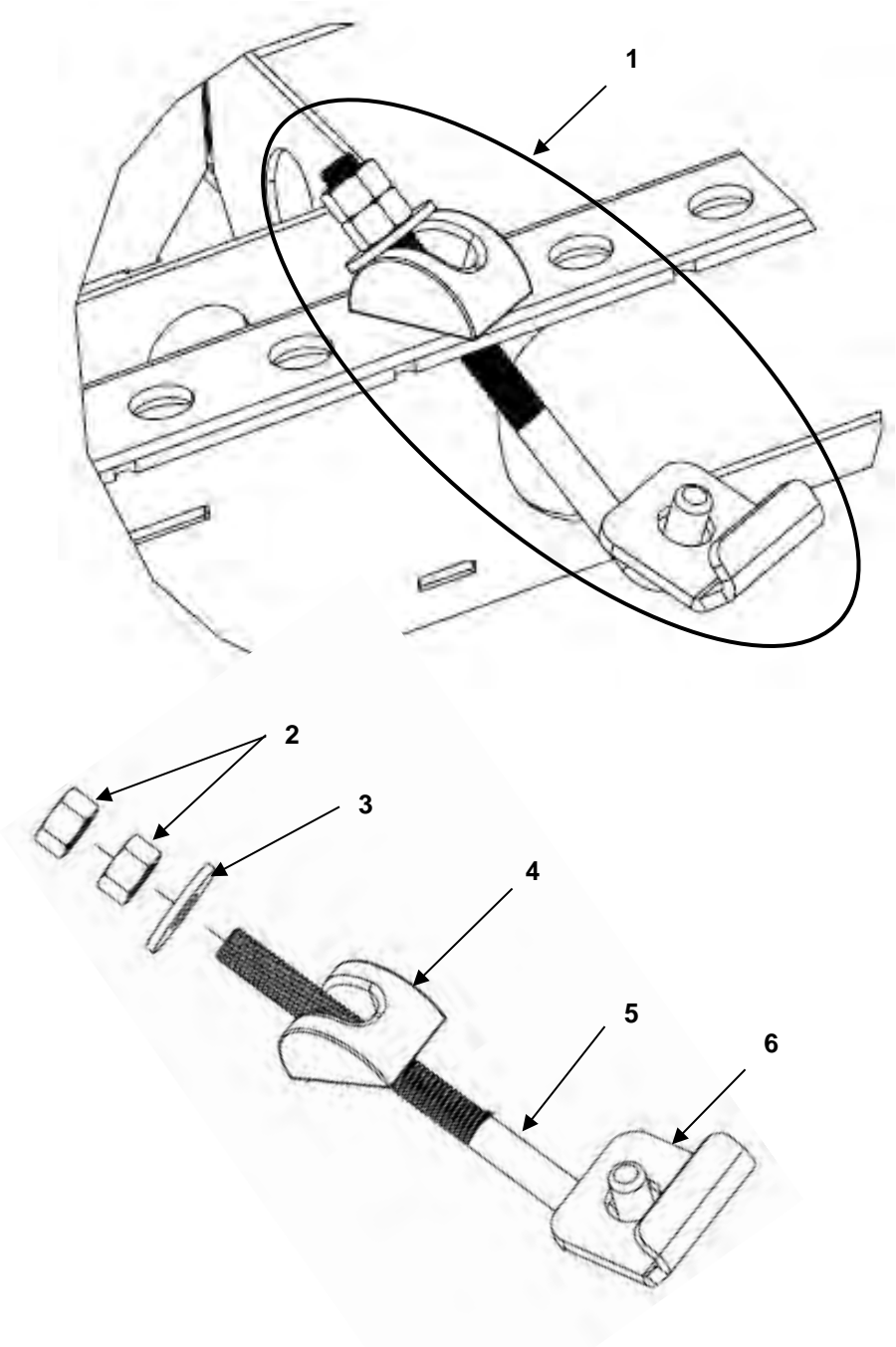

FIGURE 50 HOOK BOLT AND PLATE KIT

(1) ITEM NO.	(3) NSN	(4) CAGEC	(5) PART NUMBER	(6) DESCRIPTION AND USABLE ON CODE (UOC)	(7) QTY
				GROUP 0301 FIGURE 50 HOOK BOLT AND PLATE KIT	
1	Not Assigned	1NSG3	15988921-001	.HOOK BOLT HOOK PLATE KIT GREEN	1
1	Not Assigned	1NSG3	15988921-002	.HOOK BOLT HOOK PLATE KIT TAN	1
2	Not Assigned	1NSG3	78070308	.. NUT ZP GR8, 1/2 -13	2
3	Not Assigned	1NSG3	78370308	..FLAT WASHER ZP, 1/2 "	1
4	Not Assigned	1NSG3	15121042	.. HILLSIDE WASHER	1
5	Not Assigned	1NSG3	15121060	..ANCHOR J BOLT 1/2 -13x7"	1
6	Not Assigned	1NSG3	16070212	..HOOK PLATE	1
END OF FIGURE 50					

POSITIONER RETAINING PLATE KIT

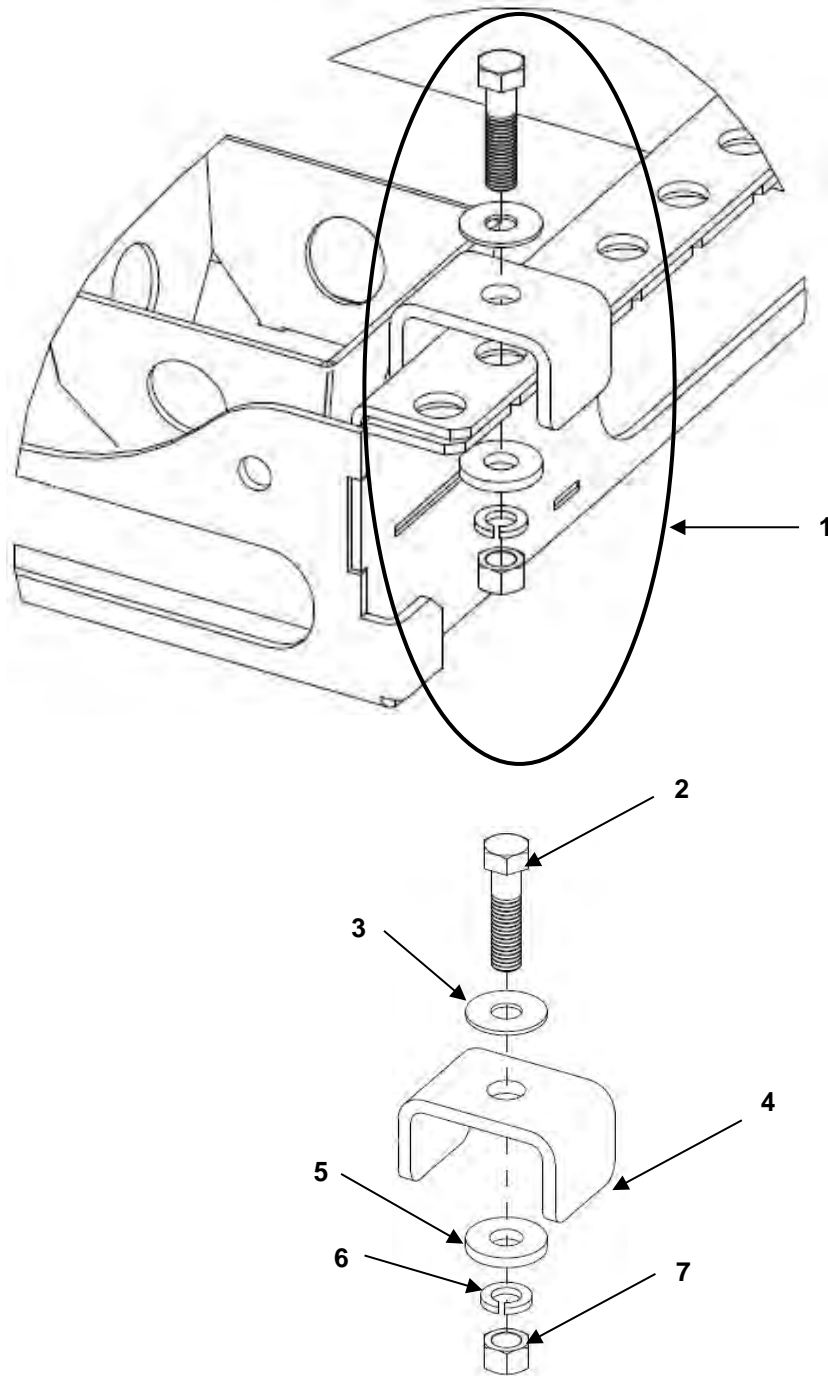

FIGURE 51 POSITIONER RETAINING PLATE KIT

0039 00-5

(1) ITEM NO.	(3) NSN	(4) CAGEC	(5) PART NUMBER	(6) DESCRIPTION AND USABLE ON CODE (UOC)	(7) QTY
				GROUP 0301 FIGURE 51 POSITIONER RETAINING PLATE KIT	
1	Not Assigned	1NSG3	15988924-001	. POSITIONER RETAINING PLATE KIT GREEN	1
1	Not Assigned	1NSG3	15988924-002	. POSITIONER RETAINING PLATE KIT TAN	1
2	Not Assigned	1NSG3	78030832	..BOLT ZP, GD8, 1/2-13x 2 "	1
3	Not Assigned	1NSG3	78330307	..WASHER FLAT ZP, GD8, 1/2"	1
4	Not Assigned	1NSG3	16070215	..POSITIONER PLATE	1
5	Not Assigned	1NSG3	16070216	..WASHER TRICON	1
6	Not Assigned	1NSG3	78330308	..LOCK WASHER HEAVY ZP, 1/2 "	1
7	Not Assigned	1NSG3	78070308	.. NUT ZP GR8, 1/2 -13	1
END OF FIGURE 51					

JACK BOLT AND NUT KIT

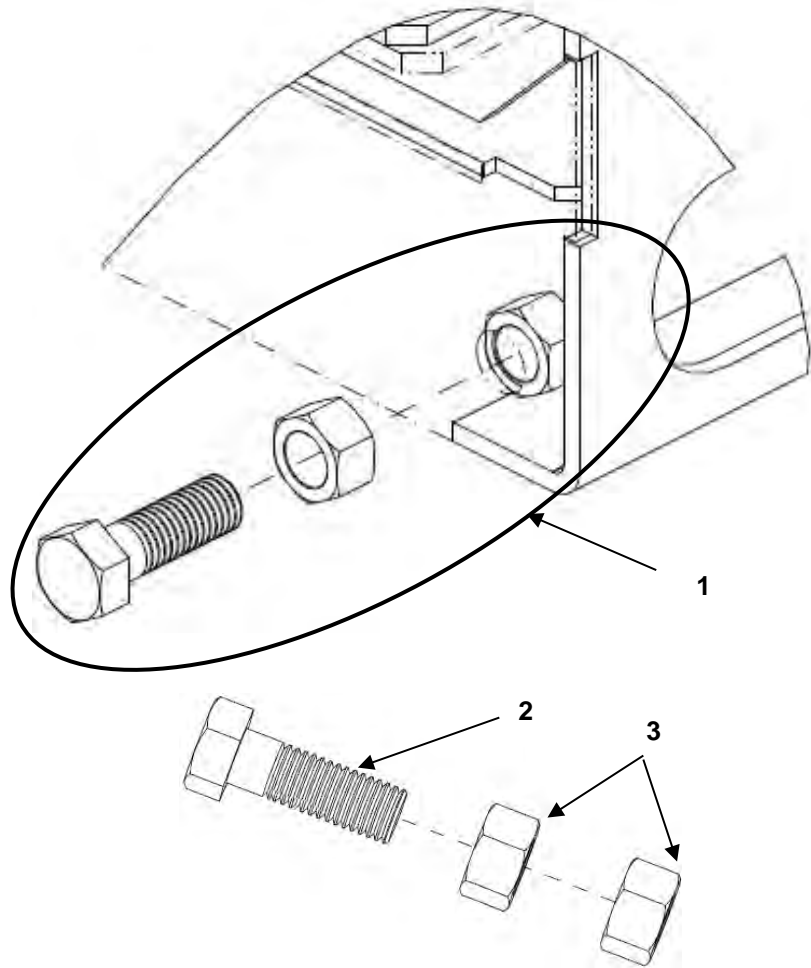

FIGURE 52 JACK BOLT AND NUT KIT

(1) ITEM NO.	(3) NSN	(4) CAGEC	(5) PART NUMBER	(6) DESCRIPTION AND USABLE ON CODE (UOC)	(7) QTY
				GROUP 0301 FIGURE 53 JACK BOLT AND NUT KIT	
1	Not Assigned	1NSG3	15988922	.JACK BOLT AND NUT KIT	1
2	Not Assigned	1NSG3	78030824	..BOLT ZP, GD8, 1/2-13 x 1-1/2 "	1
3	Not Assigned	1NSG3	78070308	.. NUT ZP GR8, 1/2 -13	2
END OF FIGURE 52					

REAR ATTACHING HARDWARE KIT

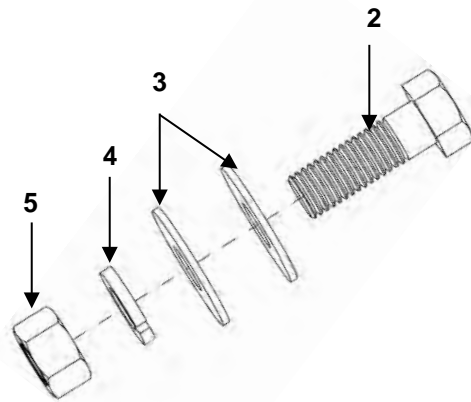
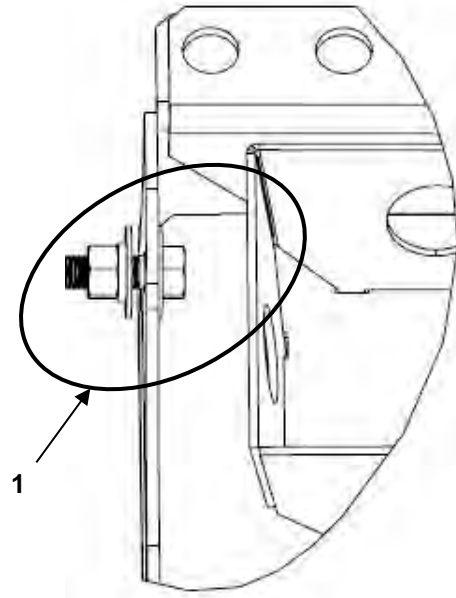

FIGURE 53 REAR ATTACHING HARDWARE KIT

(1) ITEM NO.	(3) NSN	(4) CAGEC	(5) PART NUMBER	(6) DESCRIPTION AND USABLE ON CODE (UOC)	(7) QTY
				GROUP 0301 FIGURE 53 REAR MOUNTING HARDWARE KIT	
1	Not Assigned	1NSG3	15988923	. REAR ADAPTER MOUNTING HARDWARE KIT	1
2	Not Assigned	1NSG3	78030824	..BOLT ZP, GD8, 1/2-13 x 1-1/2 "	1
3	Not Assigned	1NSG3	78370307	..FLAT WASHER ZP, 1/2 "	2
4	Not Assigned	1NSG3	78330308	..LOCK WASHER HEAVY ZP, 1/2 "	1
5	Not Assigned	1NSG3	78070308	.. NUT ZP GR8, 1/2 -13	1
END OF FIGURE 53					

TRICON MODULE KIT #1

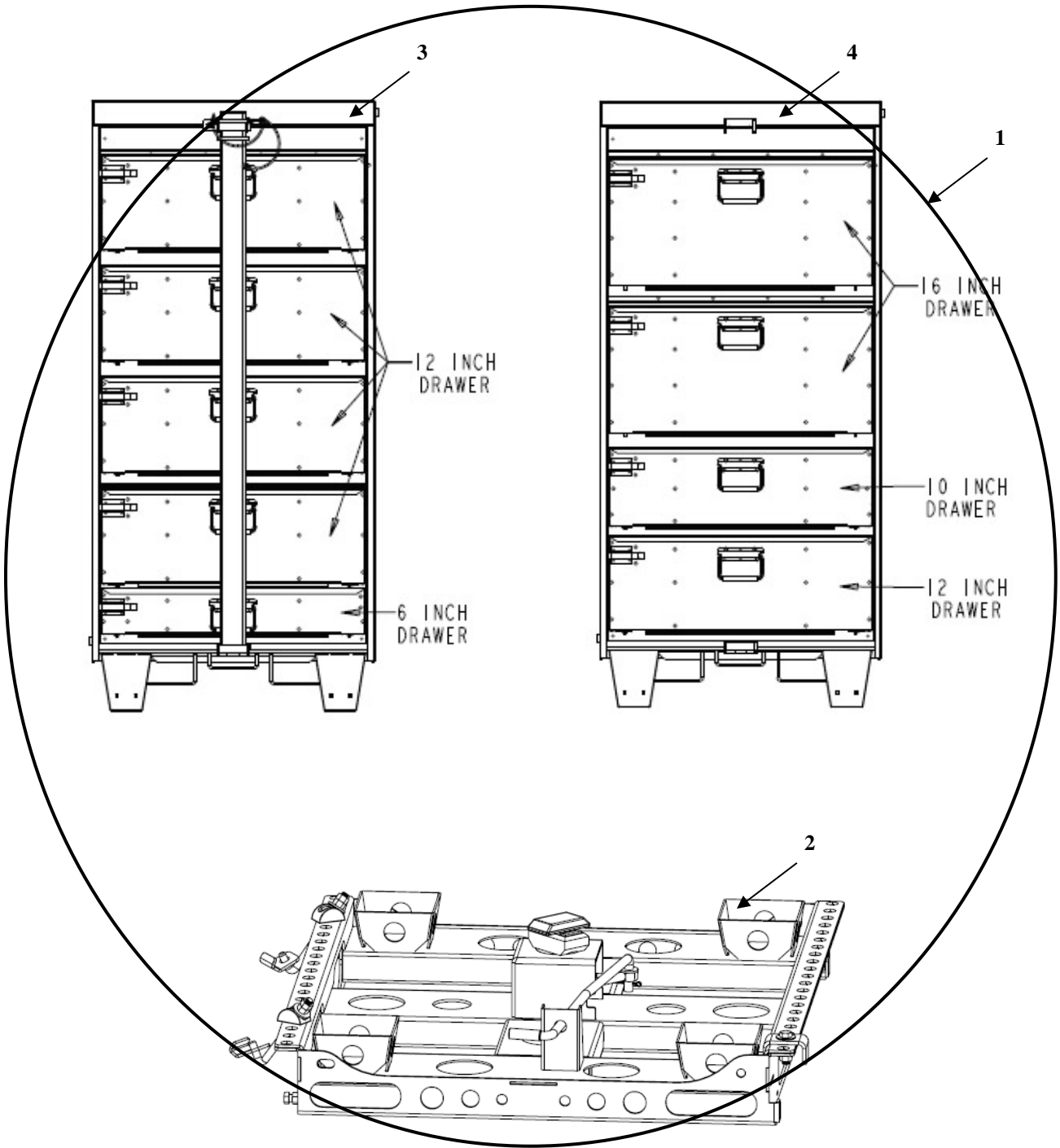

FIGURE 54 TRICON MODULE KIT #1

(1) ITEM NO.	(3) NSN	(4) CAGEC	(5) PART NUMBER	(6) DESCRIPTION AND USABLE ON CODE (UOC)	(7) QTY
				GROUP 0302 FIGURE 54 TRICON MODULE KIT #1	
1	Not Assigned	1NSG3	30000001-001	.TRICON MODULE KIT #1 - GREEN	1
1	Not Assigned	1NSG3	30000001-002	.TRICON MODULE KIT #1 - TAN	1
2	8145-01- 606-0505	1NSG3	15530128	..FPU TRICON ADAPTER W/ HDW.	2
3	8145-01- 501-0892	1NSG3	15700024	..STD. MODULE #24	1
4	8145-01- 501-0900	1NSG3	15700026	..STD. MODULE #26	1
END OF FIGURE 54					

TRICON MODULE KIT #2

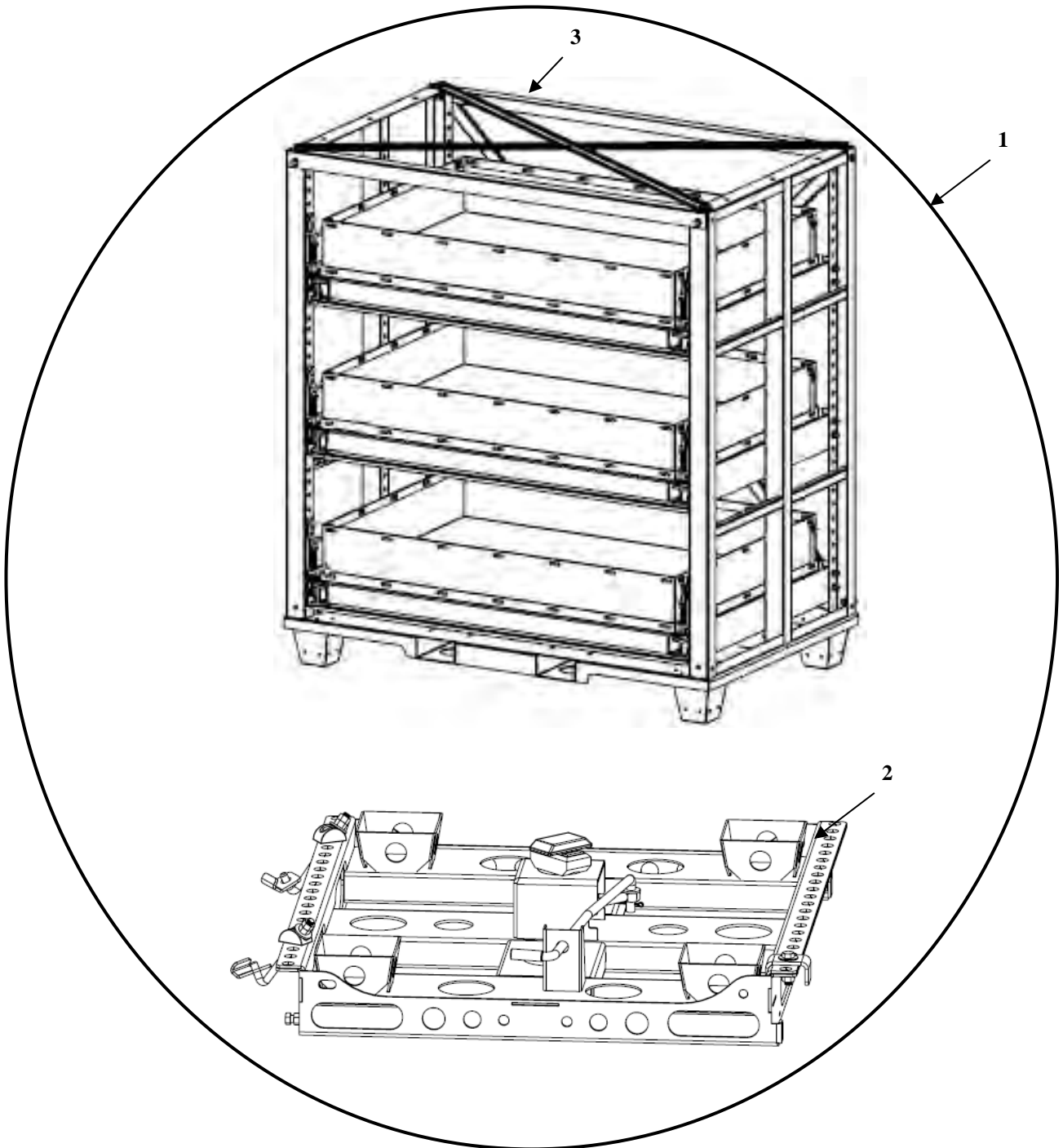

FIGURE 55 TRICON MODULE KIT #2

(1) ITEM NO.	(3) NSN	(4) CAGEC	(5) PART NUMBER	(6) DESCRIPTION AND USABLE ON CODE (UOC)	(7) QTY
				GROUP 0302 FIGURE 55 TRICON MODULE KIT #2	
1	Not Assigned	1NSG3	30000002-001	.TRICON MODULE KIT #2 – GREEN	1
1	Not Assigned	1NSG3	30000002-002	.TRICON MODULE KIT #2 – TAN	1
2	8145-01- 606-0505	1NSG3	15530128	..FPU TRICON ADAPTER W/ HDW.	2
3	8145-01- 588-3691	1NSG3	15410203	..THREE BIN BULK MODULE	1
END OF FIGURE 55					

TRICON MODULE KIT #3

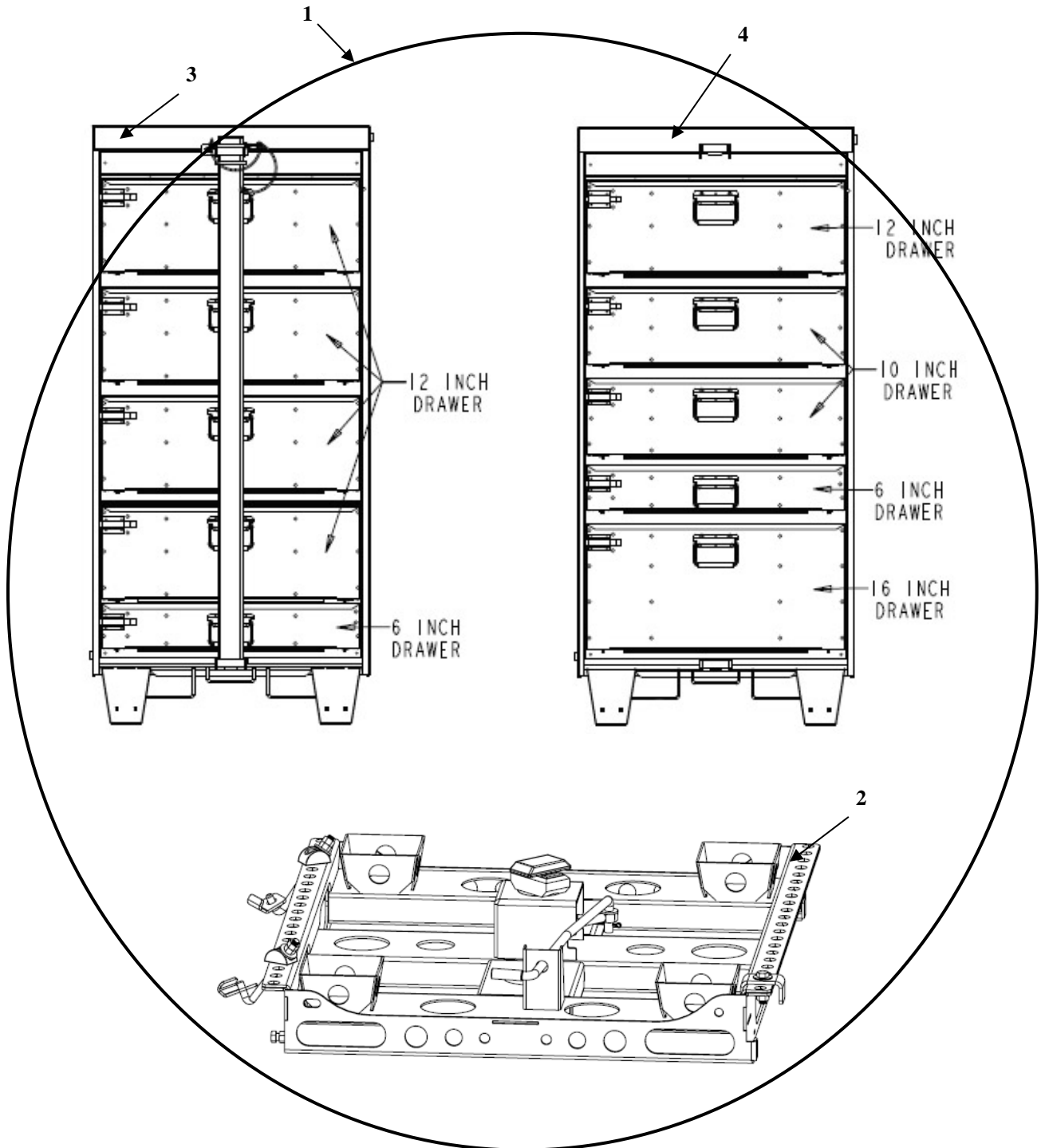

FIGURE 56 TRICON MODULE KIT #3

(1) ITEM NO.	(3) NSN	(4) CAGEC	(5) PART NUMBER	(6) DESCRIPTION AND USABLE ON CODE (UOC)	(7) QTY
				GROUP 0302 FIGURE 56 TRICON MODULE KIT #3	
1	Not Assigned	1NSG3	30000003-001	.TRICON MODULE KIT #3 - GREEN	1
1	Not Assigned	1NSG3	30000003-002	.TRICON MODULE KIT #3 - TAN	1
2	8145-01- 606-0505	1NSG3	15530128	..FPU TRICON ADAPTER W/ HDW.	2
3	8145-01- 501-0892	1NSG3	15700024	..STD. MODULE #24	1
4	8145-01- 523-4011	1NSG3	15700023	..STD. MODULE #23	1
END OF FIGURE 56					

TRICON MODULE KIT #4

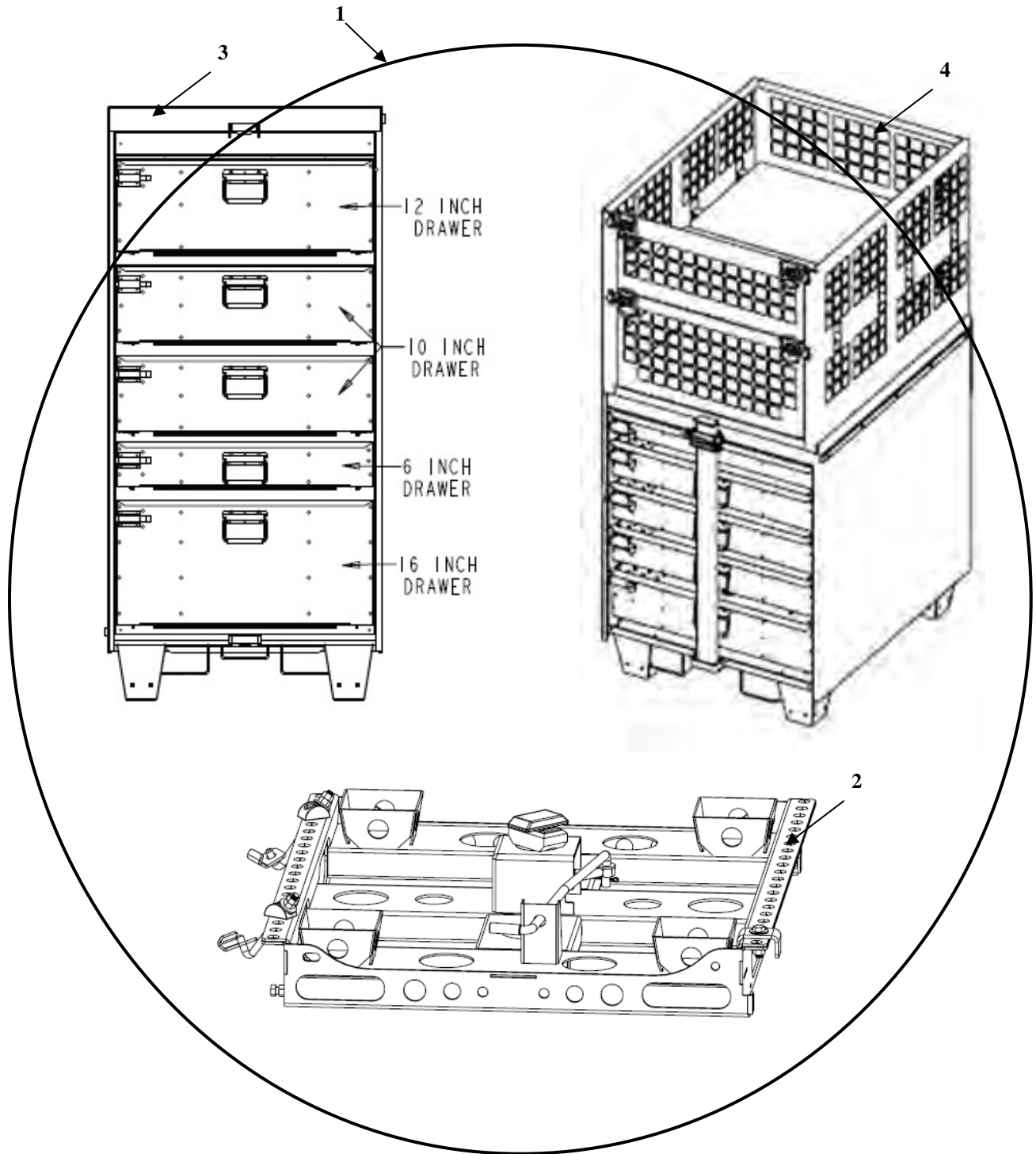

FIGURE 57 TRICON MODULE KIT #4

(1) ITEM NO.	(3) NSN	(4) CAGEC	(5) PART NUMBER	(6) DESCRIPTION AND USABLE ON CODE (UOC)	(7) QTY
				GROUP 0302 FIGURE 57 TRICON MODULE KIT #4	
1	Not Assigned	1NSG3	30000004-001	.TRICON MODULE KIT #4 - GREEN	1
1	Not Assigned	1NSG3	30000004-002	.TRICON MODULE KIT #4 - TAN	1
2	8145-01- 606-0505	1NSG3	15530128	..FPU TRICON ADAPTER W/ HDW.	2
3	8145-01- 523-4011	1NSG3	15700023	..STD. MODULE #23	1
4	8145-01- 502-0591	1NSG3	15700201	..SHORT/HELO MODULE	1
END OF FIGURE 57					

TRICON MODULE KIT #5

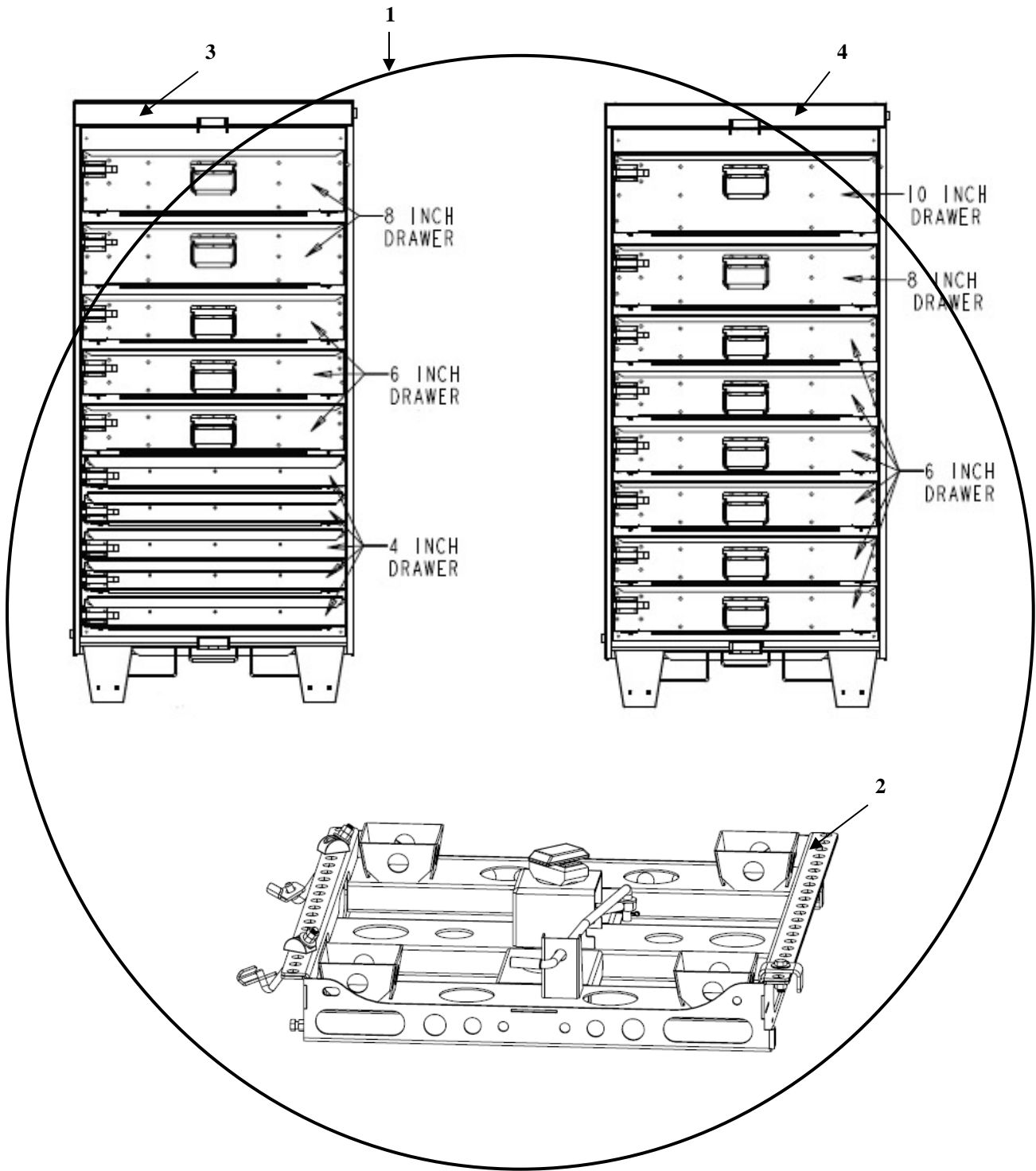

FIGURE 58 TRICON MODULE KIT #5

0039 00-19

(1) ITEM NO.	(3) NSN	(4) CAGEC	(5) PART NUMBER	(6) DESCRIPTION AND USABLE ON CODE (UOC)	(7) QTY
				GROUP 0302 FIGURE 58 TRICON MODULE KIT #5	
1	Not Assigned	1NSG3	30000005-001	.TRICON MODULE KIT #5 - GREEN	1
1	Not Assigned	1NSG3	30000005-002	.TRICON MODULE KIT #5 - TAN	1
2	8145-01- 606-0505	1NSG3	15530128	..FPU TRICON ADAPTER W/ HDW.	2
3	8145-01- 502-2494	1NSG3	15700021	..STD. MODULE #21	1
4	8145-01- 523-4040	1NSG3	15700022	..STD. MODULE #22	1
END OF FIGURE 58					

TRICON MODULE KIT #6

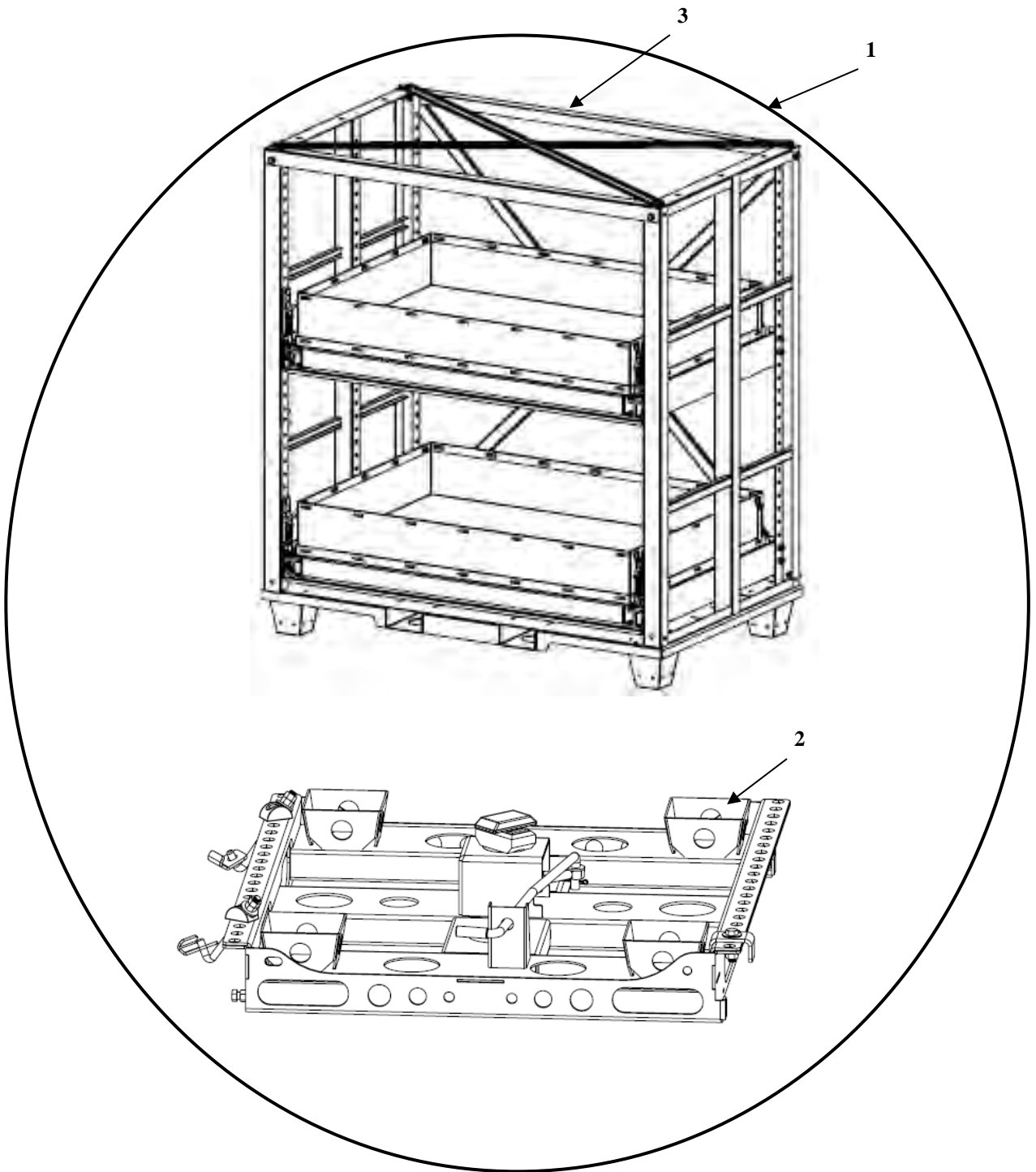

FIGURE 59 TRICON MODULE KIT #6

0039 00-21

(1) ITEM NO.	(3) NSN	(4) CAGEC	(5) PART NUMBER	(6) DESCRIPTION AND USABLE ON CODE (UOC)	(7) QTY
				GROUP 0302 FIGURE 59 TRICON MODULE KIT #6	
1	Not Assigned	1NSG3	30000006-001	.TRICON MODULE KIT #6 - GREEN	1
1	Not Assigned	1NSG3	30000006-002	.TRICON MODULE KIT #6 - TAN	1
2	8145-01- 606-0505	1NSG3	15530128	..FPU TRICON ADAPTER W/ HDW.	2
3	8145-01- 588-3690	1NSG3	15410204	..TWO BIN BULK MODULE	1
END OF FIGURE 59					

END OF WORK PACKAGE

This page was intentionally left blank

PARTS SUPPORTING INFORMATION

**FPU SYSTEMS OPERATION MANUAL
(INCLUDING REPAIR PARTS & SPECIAL TOOL LIST)
STANDARD AND SPECIALIZED FPU MODULES
BOH FPU Field Pack-up Units**

NSN INDEX

NSN	FIG.	ITEM
8145-01-473-1218	11	3
8145-01-473-1218	12	4
8145-01-473-1218	14	5
8145-01-473-1218	16	4
8145-01-473-1218	18	3
8145-01-473-1218	19	4
8145-01-473-1218	20	2
8145-01-473-1218	21	4
8145-01-473-1218	22	1
8145-01-473-1218	27	1
8145-01-473-1218	28	1
8145-01-473-1226	4	2
8145-01-473-1226	10	3
8145-01-473-1226	12	3
8145-01-473-1226	13	3
8145-01-473-1226	14	3
8145-01-473-1226	15	3
8145-01-473-1226	16	2
8145-01-473-1226	17	3
8145-01-473-1226	21	2
8145-01-473-1226	22	8
8145-01-473-1226	27	5
8145-01-473-1226	28	6
8145-01-473-1275	3	3
8145-01-473-1275	5	4
8145-01-473-1275	7	2
8145-01-473-1275	8	2
8145-01-473-1275	9	2

NSN	FIG.	ITEM
8145-01-473-1275	10	2
8145-01-473-1275	11	2
8145-01-473-1275	19	2
8145-01-473-1275	23	6
8145-01-473-1283	3	4
8145-01-473-1283	4	4
8145-01-473-1283	6	2
8145-01-473-1283	9	4
8145-01-473-1283	10	4
8145-01-473-1283	11	4
8145-01-473-1283	12	5
8145-01-473-1283	13	4
8145-01-473-1283	14	6
8145-01-473-1283	15	4
8145-01-473-1283	16	5
8145-01-473-1283	18	4
8145-01-473-1283	19	5
8145-01-473-1283	20	3
8145-01-473-1283	23	10
8145-01-473-1288	25	1
8145-01-473-1319	7	3
8145-01-473-1319	8	4
8145-01-473-1319	13	2
8145-01-473-1319	14	4
8145-01-473-1319	15	2
8145-01-473-1319	16	3
8145-01-473-1319	17	4
8145-01-473-1319	18	2

0040 00-1

NSN	FIG.	ITEM
8145-01-473-1319	19	3
8145-01-473-1319	21	3
8145-01-473-1319	22	7
8145-01-473-1319	27	4
8145-01-473-1319	28	5
8145-01-473-1351	5	3
8145-01-473-1351	8	3
8145-01-473-1351	9	3
8145-01-473-1351	12	2
8145-01-473-1351	17	2
8145-01-473-1351	23	1
8145-01-473-1527	3	2
8145-01-473-1527	4	3
8145-01-473-1527	5	2
8145-01-473-1527	8	5
8145-01-473-1527	14	2
8145-01-473-1527	23	7
8145-01-501-0865	10	1
8145-01-501-0866	18	1
8145-01-501-0869	12	1
8145-01-501-0892	7	1
8145-01-501-0892	54	3
8145-01-501-0892	56	3
8145-01-501-0896	6	1
8145-01-501-0900	5	1
8145-01-501-0900	54	4
8145-01-502-0591	57	4
8145-01-502-2491	20	1
8145-01-502-2494	21	1
8145-01-502-2494	58	3
8145-01-502-2593	30	1
8145-01-502-2605	30	3
8145-01-502-2611	30	2
8145-01-502-2611	37	1

NSN	FIG.	ITEM
8145-01-502-2611	38	1
8145-01-502-2630	1	3
8145-01-522-0667	19	1
8145-01-523-4000	4	1
8145-01-523-4003	3	1
8145-01-523-4005	9	1
8145-01-523-4011	8	1
8145-01-523-4011	56	4
8145-01-523-4011	57	3
8145-01-523-4014	11	1
8145-01-523-4022	13	1
8145-01-523-4025	15	1
8145-01-523-4028	14	1
8145-01-523-4039	16	1
8145-01-523-4040	17	1
8145-01-523-4040	58	4
8145-01-523-4068	23A	2
8145-01-523-4068	29	2
8145-01-523-4076	2	1
8145-01-523-4138	23B	8
8145-01-523-4140	23B	6
8145-01-523-4142	23B	4
8145-01-523-4145	23B	2
8145-01-523-4145	29	8
8145-01-523-4149	23A	6
8145-01-523-4149	29	6
8145-01-523-4591	23A	5
8145-01-523-4591	29	5
8145-01-523-4592	23A	3
8145-01-523-4592	29	3
8145-01-528-2853	30	5
8145-01-588-3689	43	1
8145-01-588-3690	43	2
8145-01-588-3691	43	3

NSN	FIG.	ITEM
8145-01-588-3691	55	3
8145-01-588-3692	43	4
8145-01-588-3692	59	3
8145-01-606-0505	48	1
8145-01-606-0505	54	2
8145-01-606-0505	55	2
8145-01-606-0505	56	2
8145-01-606-0505	57	2
8145-01-606-0505	58	2
8145-01-606-0505	59	2
END OF NSN TABLE		

END OF WORK PACKAGE

This page was intentionally left blank

PARTS SUPPORTING INFORMATION

**FPU SYSTEMS OPERATION MANUAL
(INCLUDING REPAIR PARTS & SPECIAL TOOL LIST)
STANDARD AND SPECIALIZED FPU MODULES
BOH FPU Field Pack-up Units**

PART NUMBER INDEX

PART NUMBER	FIG.	ITEM
15080130	34	7
15100122	33	4
15100310	32A	4
15120662	1	5
15120665	25	6
15121042	50	4
15121054	22	5
15121054	23	4
15121054	28	3
15121054	22	5
15121055	22	6
15121055	22	6
15121055	23	5
15121055	28	4
15121060	49	5
15172034	38	7
15410079	42	5
15410079	45	2
15410083	45	3
15410085	45	6
15410203	55	3
15410204	59	3
15510000	24	1
15510000	42	1
15510101	24	2
15510101	42	2
15510102	24	3

PART NUMBER	FIG.	ITEM
15510102	41	3
15108440	32A	2
15522021	1	2
15522022	41	5
15522023	3	5
15522023	4	5
15522023	6	3
15522023	9	5
15522023	10	5
15522023	11	5
15522023	12	6
15522023	13	5
15522023	14	7
15522023	15	5
15522023	16	6
15522023	18	5
15522023	19	6
15522023	20	4
15522023	23	11
15522024	40	2
15524001	23A	2
15524001	29	2
15524002	23A	3
15524002	29	3
15524003	23A	5
15524003	29	5
15524004	23A	6

PART NUMBER	FIG.	ITEM
15524004	29	6
15524005	23B	2
15524005	29	8
15524006	23B	4
15524007	23B	6
15524008	23B	8
15530128	54	2
15530128	55	2
15530128	56	2
15530128	57	2
15530128	58	2
15530128	59	2
15640322	37	5
15700021	58	3
15700022	58	4
15700023	56	4
15700023	57	3
15700024	54	3
15700024	56	3
15700026	54	4
15700201	57	4
15981873	35	3
15981875	31	2
15981876	31	1
15981879	31	3
15981888	37	8
15981894	34	3
15981894	35	7
15981900	22	3
15981900	23	2
15981900	28	8
15981901	22	4
15981901	23	3
15981901	28	7
15981902	23	8

PART NUMBER	FIG.	ITEM
15981903	23	9
15988249	38	3
15988249	38	4
15988249	38	3
15988588	39	2
15988596	38	5
15988599	40	2
15988612	31	4
15988615	23A	1
15988615	29	1
15988616	23A	4
15988616	29	4
15988617	23A	1
15988617	29	7
15988618	23B	3
15988619	23B	5
15988620	23B	7
15988700	33	1
15988700	40	3
15988720	34	10
15988720	35	8
15988721	37	4
15988722	37	3
15988723	37	2
15988724	37	9
15988734	34	9
15988734	35	5
15988906	43	8
15988915	47	2
15988916	47	1
15988920	47	2
15988922	47	4
15988922	51	1
15988923	48	3
15988923	52	1
15988925	46	3

PART NUMBER	FIG.	ITEM
15988933	46	5
15988934	46	4
15988935	46	8
15988936	46	7
15988937	46	6
16011040	39	5
16011050	33	3
16011051	33	2
16011070	39	4
16020424	27	3
16030038	32A	3
16035014	32A	1
16035063	35	2
16070212	49	6
16070215	50	4
16070216	50	5
16090002	37	7
16090005	37	6
16130004	36	3
16141628	34	4
16141628	34	4
16141639	34	5
16141641	34	6
16141642	34	8
16502505	22	2
16502505	27	2
16502505	28	2
74090520	36	4
74100502	36	2
78030824	52	2
78030824	53	2
78030832	51	2
78070308	49	2
78070308	51	7
78070308	52	3

PART NUMBER	FIG.	ITEM
78070308	53	5
78330308	51	3
78330308	51	6
78330308	53	4
78370307	53	3
78370308	50	3
80760232	38	2
15410001-001	44	1
15410001-002	44	1
15410026-001	44	5
15410026-002	44	5
15410201-001	43	1
15410201-002	43	1
15410202-001	43	2
15410202-002	43	2
15410203-001	43	3
15410203-002	43	3
15410204-001	43	4
15410204-002	42	4
15500003-001	30	1
15500003-002	30	1
15500016-001	5	2
15500101-001	38	1
15500101-002	38	1
15500102-001	30	2
15500102-001	30	5
15500102-001	36	1
15500102-001	37	1
15500102-002	30	2
15500102-002	30	5
15500102-002	36	1
15500102-002	37	1
15500103-001	30	3
15500103-001	34	1
15500103-002	30	3

PART NUMBER	FIG.	ITEM
15500103-002	34	1
15500104-001	30	4
15500104-001	35	1
15500104-002	30	4
15500104-002	35	1
15520001-001	3	4
15520001-001	4	4
15520001-001	6	2
15520001-001	9	4
15520001-001	10	4
15520001-001	11	4
15520001-001	12	5
15520001-001	13	4
15520001-001	14	6
15520001-001	15	4
15520001-001	16	5
15520001-001	18	4
15520001-001	19	5
15520001-001	20	3
15520001-001	23	10
15520001-002	3	4
15520001-002	4	4
15520001-002	6	2
15520001-002	9	4
15520001-002	10	4
15520001-002	11	4
15520001-002	12	5
15520001-002	13	4
15520001-002	14	6
15520001-002	15	4
15520001-002	16	5
15520001-002	18	4
15520001-002	19	5
15520001-002	20	3
15520001-002	23	10

PART NUMBER	FIG.	ITEM
15520400-001	11	3
15520400-001	12	4
15520400-001	14	5
15520400-001	16	4
15520400-002	18	3
15520400-002	19	4
15520400-002	20	2
15520400-002	21	4
15520400-002	22	1
15520400-002	27	1
15520400-002	28	1
15520600-001	7	3
15520600-001	8	4
15520600-001	13	2
15520600-001	14	4
15520600-001	15	2
15520600-001	16	3
15520600-001	17	4
15520600-001	18	2
15520600-001	19	3
15520600-001	21	3
15520600-001	22	7
15520600-001	27	4
15520600-001	28	5
15520600-002	7	3
15520600-002	8	4
15520600-002	13	2
15520600-002	14	4
15520600-002	15	2
15520600-002	16	3
15520600-002	17	4
15520600-002	18	2
15520600-002	19	3
15520600-002	21	3
15520600-002	22	7

PART NUMBER	FIG.	ITEM
15520600-002	27	4
15520600-002	28	5
15520800-001	4	2
15520800-001	10	3
15520800-001	12	3
15520800-001	13	3
15520800-001	14	3
15520800-001	15	3
15520800-002	16	2
15520800-002	17	3
15520800-002	21	2
15520800-002	22	8
15520800-002	27	5
15520800-002	28	6
15521000-001	23	1
15521000-001	5	3
15521000-001	8	3
15521000-001	9	3
15521000-001	12	2
15521000-001	17	2
15521000-002	23	1
15521000-002	5	3
15521000-002	8	3
15521000-002	9	3
15521000-002	12	2
15521000-002	17	2
15521200-001	3	3
15521200-001	5	4
15521200-001	7	2
15521200-001	8	2
15521200-001	9	2
15521200-001	10	2
15521200-001	11	2
15521200-001	19	2
15521200-001	23	6

PART NUMBER	FIG.	ITEM
15521200-002	3	3
15521200-002	5	4
15521200-002	7	2
15521200-002	8	2
15521200-002	9	2
15521200-002	10	2
15521200-002	11	2
15521200-002	19	2
15521200-002	23	6
15521600-001	23	7
15521600-002	23	7
15522002	1	1
Omitted		
15522004	2	1
Omitted		
15522005	25	3
Omitted	-	-
15522009	2	2
Omitted	-	-
15530128-001	48	1
15530128-002	48	1
15700003-001	11	1
15700003-002	11	1
15700005-001	9	1
15700005-002	9	1
15700007-001	10	1
15700007-002	10	1
15700008-001	4	1
15700008-002	4	1
15700009-001	3	1
15700009-002	3	1
15700011-001	19	1
15700011-002	19	1
15700013-001	18	1
15700013-002	18	1

PART NUMBER	FIG.	ITEM
15700014-001	12	1
15700014-002	12	1
15700016-001	3	2
15700016-001	4	3
15700016-001	8	5
15700016-001	14	1
15700016-001	14	2
15700016-002	3	2
15700016-002	4	3
15700016-002	5	2
15700016-002	8	5
15700016-002	14	1
15700016-002	14	2
15700017-001	20	1
15700017-002	20	1
15700018-001	15	1
15700018-002	15	1
15700019-001	13	1
15700019-002	13	1
15700020-001	16	1
15700020-002	16	1
15700021-001	21	1
15700021-002	21	1
15700022-001	17	1
15700022-002	17	1
15700023-001	8	1
15700023-002	8	1
15700024-001	7	1
15700024-002	7	1
15700025-001	6	1
15700025-002	6	1
15700026-001	5	1
15700026-002	5	1
15700201-001	25	1
15700201-002	25	1

PART NUMBER	FIG.	ITEM
15981880-001	32	1
15981880-002	32	1
15981883-001	32	4
15981883-002	32	4
15981884-001	32	2
15981884-002	32	2
15981885-001	32	3
15981885-002	32	3
15981899-001	30	1*
15981899-002	30	2*
15988248-001	1	4
15988248-001	25	5
15988248-002	1	4
15988248-002	25	5
15988248-002	25	5
15988590-001	41	4
15988590-002	41	4
15988591-001	41	3
15988591-002	41	3
15988595-001	38	6
15988595-002	38	6
15988605-001	49	1
15988605-002	49	1
15988733-001	34	2
15988733-001	35	6
15988733-002	34	2
15988733-002	35	6
15988905-001	43	4
15988905-002	43	4
15988907-001	45	4
15988907-002	45	4
15988908-001	45	5
15988908-002	45	5
15988910-001	44	1
15988910-002	44	1

PART NUMBER	FIG.	ITEM
15988912-001	44	6
15988912-002	44	6
15988913-001	44	2
15988913-002	44	2
15988914-001	44	3
15988914-002	44	3
15988919-001	46	1
15988919-002	47	1
15988921-001	47	5
15988921-001	50	1
15988921-002	49	5
15988921-002	50	1
15988924-001	49	2
15988924-001	51	1
15988924-002	49	2
15988924-002	51	1
15988938-001	44	7
15988938-002	44	7
16011024-001	39	1
16011024-002	39	1
16011054-001	41	1
16011054-002	41	1
16011065-001	39	1
16011065-002	39	1
16035056-001	35	4
16035056-002	35	4
16061017-001	1	3
16061017-002	1	3
16500340-001	25	2
16500340-001	26	1
16500340-002	25	2
16500340-002	26	1
16500341-001	26	2
16500341-002	26	2
16500380-001	25	4

PART NUMBER	FIG.	ITEM
16500380-002	25	4
30000001-001	54	1
30000001-002	54	1
30000002-001	55	1
30000002-002	55	1
30000003-001	56	1
30000003-002	56	1
30000004-001	57	1
30000004-002	57	1
30000005-001	58	1
30000005-002	58	1
30000006-001	59	1
30000006-002	59	1
74100545-001	26	3
74100545-002	26	3
END OF PARTS NUMBER TABLE		

END OF WORK PACKAGE

Boh Environmental, LLC

MANUFACTURER'S LIMITED WARRANTY TERMS

Boh Environmental, LLC (BOH) warrants that the Products offered, including the Field Pack-Up (FPU[®]) System, Containerized Mission Systems, Module Kits, and Bare Base Equipment, shall be free from defects in materials and workmanship for a period of twelve (12) months from date of purchase when normally used, maintained and operated by the Customer. Unused Product containing missing or defective components may be returned, within the warranty period, with proof of purchase, to BOH with transportation charges prepaid. BOH, at its option, shall supply a replacement item(s) or refund the purchase price of the Product. BOH shall in its sole discretion determine whether to replace the defective item(s) with identical items, or with items of identical quality and providing identical performance and functional capabilities. BOH will determine, at its sole discretion, whether or not the claim is a valid warranty item. If so, BOH will pay costs (actual transportation plus handling charge) for shipping of the replacement item, when this option is selected.

This warranty is void if Products have been damaged by the Customer as the result of improper or unreasonable use, or other causes not arising out of defects in material or workmanship. The warranty is also void if the Product has at any time been stored or used other than in accordance with the directions set out in the literature relating to the Product (e.g., user/operation manuals). BOH makes no other warranty or representation concerning the Products except that each will meet the performance specifications set forth in the literature relating to the Product. There are no further warranties, including any warranty of merchantability or fitness for a particular purpose covering the Product.

BOH will, at its option, either (1) credit user in the amount paid for any Product which does not perform to these specifications, or (2) replace or repair such Product, provided user so notifies BOH within twelve (12) months of the Products purchase date. BOH shall not be responsible for any consequential damages to user arising as a result of such performance. The Customer will return the item at their cost, if required. Boh may elect to have its representative inspect the item to validate the claim.

Other product components included in the fabrication of items purchased under contract (e.g., air conditioners and generators) that are not manufactured by Boh Environmental are warranted by their individual manufacturer. Copies of such warranties are supplied with the finished Product or are available through BOH.

Please contact BOH for other contract specific warranty terms

This page was intentionally left blank

THE METRIC SYSTEM AND EQUIVALENTS

Linear Measure

1 centimeter = 10 millimeters = .39 inch

1 decimeter = 10 centimeters = 3.94 inches

1 meter = 10 decimeters = 39.37 inches

1 decameter = 10 meters = 32.8 feet

1 hectometer = 10 decameters = 328.08 feet

1 kilometer = 10 hectometers = 3,280.8 feet

Liquid Measure

1 centiliter = 10 milliliters = .34 fl. ounce

1 deciliter = 10 centiliters = 3.38 fl. ounces

1 liter = 10 deciliters = 33.81 fl. ounces

1 deciliter = 10 liters = 2.64 gallons

1 hectoliter = 10 deciliters = 26.42 gallons

1 kiloliter = 10 hectoliters = 264.18 gallons

Weights

1 centigram = 10 milligrams = .15 grain

1 decigram = 10 centigrams = 1.54 grains

1 gram = 10 decigrams = .035 ounce

1 dekagram = 10 grams = .35 ounce

1 hectogram = 10 dekagrams = 3.52 ounces

1 kilogram = 10 hectograms = 2.2 pounds

1 quintal = 100 kilograms = 220.46 pounds

1 metric ton = 10 quintals = 1.1 short tons

Square Measure

1 sq. centimeter = 100 sq. millimeters = .155 sq. inch

1 sq. decimeter = 100 sq. centimeters = 15.5 sq. inches

1 sq. meter (centare) = 100 sq. decimeters = 10.76 sq. feet

1 sq. decameter (are) = 100 sq. meters = 1,076.4 sq. feet

1 sq. hectometer (hectare) = 100 sq. decameters = 2.47 acres

1 sq. kilometer = 100 sq. hectometers = .386 sq. mile

Cubic Measure

1 cu. centimeter = 1000 cu. millimeters = .06 cu. inch

1 cu. decimeter = 1000 cu. centimeters = 61.02 cu. inches

1 cu. meter = 1000 cu. decimeters = 35.31 feet

Approximate Conversion Factors

To change	To	Multiply by	To change	To	Multiply by
Inches	centimeters	2.540	ounce/inches	Newton/meters	0.007062
feet	meters	0.305	centimeters	inches	0.394
yards	meters	0.914	meters	feet	3.280
miles	kilometers	1.609	meters	yards	1.094
square inches	square centimeters	6.451	kilometers	miles	0.621
square feet	square meters	0.093	square centimeters	square inches	0.155
square yards	square meters	0.836	square meters	square feet	10.764
square miles	square kilometers	2.590	square meters	square yards	1.196
acres	square hectometers	0.405	square kilometers	square miles	0.386
cubic feet	cubic meters	0.028	square hectometers	acres	2.471
cubic yards	cubic meters	0.765	cubic meters	cubic feet	35.315
fluid ounces	milliliters	29.573	cubic meters	cubic yards	1.308
pints	liters	0.473	milliliters	fluid ounces	0.034
quarts	liters	0.946	liters	pints	2.113
gallons	liters	3.785	liters	quarts	1.057
ounces	grams	28.349	liters	gallons	0.264
pounds	kilograms	0.454	grams	ounces	0.035
short tons	metric tons	0.907	kilograms	pounds	2.205
pound/feet	Newton/meters	1.356	metric tons	short tons	1.102
pound/inches	Newton /meters	0.11296			

Temperature (Exact)

$\frac{5}{9}$ (after subtracting 32)
 $\frac{F - 32}{9} = C$