

**FPU® SYSTEMS OPERATION MANUAL
(INCLUDING REPAIR PARTS)
EXPEDITIONARY CONTAINERIZED AUTHORIZED STOCKAGE LIST (ECASL)
BOH FPU Field Pack-up Units**

European Patent Number EP 1224127

CHAPTER 4

OPERATOR MAINTENANCE INSTRUCTIONS

This page was intentionally left blank

OPERATOR MAINTENANCE INSTRUCTIONS

FPU® SYSTEMS OPERATION MANUAL (INCLUDING REPAIR PARTS) EXPEDITIONARY CONTAINERIZED AUTHORIZED STOCKAGE LIST (ECASL) BOH FPU Field Pack-up Units

INTRODUCTION TO PREVENTATIVE MAINTENANCE CHECKS & SERVICES (PMCS)

INITIAL SETUP:

Materiel/Parts

None

Personnel Required

One

References

None

Equipment Condition

ECASL SYSTEM Set-up

INTRODUCTION TO PREVENTATIVE MAINTENANCE CHECKS & SERVICES (PMCS)

Preventative Maintenance Checks and Services (PMCS) are performed to keep the ECASL system components in good operating condition. These checks aid in finding, correcting, or reporting problems. Operator personnel are to perform the PMCS tasks as shown in the PMCS table.

Perform PMCS procedures each day the ECASL System is in operation, using the PMCS table in (WP 0016 00). There are different intervals to perform PMCS procedures: before, during and after using the equipment, as well as weekly and monthly. Look at the table carefully to identify the required PMCS interval.

Perform all checks and services keeping in mind the following guidelines:

- Before you begin using the ECASL System, perform **Before Operation PMCS** checks and services.
- While the ECASL System is in use, perform **During Operation PMCS** checks and services.
- After using the ECASL System, perform **After Operation PMCS** checks and services.

If you find something wrong when performing PMCS, fix it using troubleshooting and/or maintenance procedures. Pay attention to WARNING and CAUTION statements. A **WARNING** means someone could be injured or killed. A **CAUTION** means equipment could be damaged.

If tools that are required to perform PMCS are not listed in the procedures, notify your supervisor.

Inspection

Look for signs of trouble. Use your senses to feel, smell, hear, or see problems that may exist. Inspect to see if items are in good condition. Are components correctly installed and secured? Is any damage to the frame or components visible? Correct any faults or notify Maintenance.

Service

Proper service of the ECASL system components is an integral part of maintenance. Regular cleaning prevents possible problems in the future, so make it a habit to clean the ECASL system components whenever necessary.

END OF WORK PACKAGE

This page was intentionally left blank

OPERATOR MAINTENANCE INSTRUCTIONS

FPU® SYSTEMS OPERATION MANUAL (INCLUDING REPAIR PARTS) EXPEDITIONARY CONTAINERIZED AUTHORIZED STOCKAGE LIST (ECASL) BOH FPU Field Pack-up Units

PMCS TABLE

INITIAL SETUP:
Materiel/Parts

Rags, Water

Personnel Required

One

References

None

Equipment Condition

ECASL SYSTEM Set-up

**Table 1 Preventative Maintenance Checks and Services for the ECASL SYSTEM
PMCS B (Before), D (During), A (After), W (Weekly), M (Monthly)**

	B	D	A	W	M	Inspection Item and Procedure	Equipment Not Ready/Available If
1	*	*	*			Doors, Walls Check all doors and walls for cracks, dents, holes, or loose/missing hardware.	Missing doors, punctures, damage that would cause hazard or injury.
	*	*	*			Check storage aids and vertical rack frames for cracks or loose/missing hardware	Damage that would cause hazard or injury.
					*	Lubricate hinges, locks, drawer slides and latches as required. NOTE: the FPU bulk module tray or bin guides do not require lubrication.	Hinges, locks, drawer slides, bins, trays and latches do not move freely.
2			*	*		Exterior Check all exterior surfaces of containers and modules for cracks, dents that effect the operation of the ECASL System. Check for accumulations of dirt, debris, ice, snow, or salt. Clean as required.	Damage or malfunction that would cause the ECASL SYSTEM from operating properly which can cause hazard or injury.
3			*	*		Interior Check container floor for dirt and debris. Clean with broom or rags as required. Check module cradles for cracks or missing rubber pads. Schedule cracked cradles for repair. Check center ISO locks for cracks or missing items. Check module-locking levers for missing or loose cotter pins. Replace or tighten as necessary. Check roof access steps for cracks or missing components. Replace as necessary.	Module cradles missing or damaged so that module does not seat properly, center ISO twist locks are broken or missing or roof access steps cracked or missing which can cause hazard or injury.
			*	*		Check module drawer slides for dirt and debris. Clean with rags and lubricate as required. Check module drawer latches for missing or loose hardware. Replace or tighten as necessary.	Module drawer slides do not roll smoothly. Drawer latches and securing devices are missing or damaged.

**Table 1 Preventative Maintenance Checks and Services for the ECASL SYSTEM (continued)
PMCS B (Before), D (During), A (After), W (Weekly), M (Monthly)**

	B	D	A	W	M	Inspection Item and Procedure	Equipment Not Ready/Available If
			*	*		Check bulk module hull for cracks or missing items. Check all module drawer latches for missing or loose hardware. Replace or tighten as necessary.	Drawer latches and securing devices are missing or damaged. FPU bulk module base cradle is damaged so that module does not seat properly.
4			*		*	Data Plates Check plates and weight signage for legibility, damage and/or missing information. Clean with water and rag. Replace as needed.	ISO/CSC Safety Data plates must be replaced if missing or system will be non-deployable. All module ID plates and weight limit signage on bulk module trays and bins are not legible.
End of Table 1 PMCS							

END OF WORK PACKAGE

OPERATOR MAINTENANCE INSTRUCTIONS

FPU® SYSTEMS OPERATION MANUAL (INCLUDING REPAIR PARTS) EXPEDITIONARY CONTAINERIZED AUTHORIZED STOCKAGE LIST (ECASL) BOH FPU Field Pack-up Units

CLEANING AND LUBRICATING

INITIAL SETUP:
Materiel/Parts

Rags, Water, Detergent

Personnel Required

One

References

None

Equipment Condition

ECASL SYSTEM Set-up

CLEANING AND LUBRICATING

Cleaning and Lubricating of the ECASL System is performed to keep the system components in good operating condition. The cleaning and lubrication of the ECASL System can be conducted along with the Preventative Maintenance Checks and Services (PMCS) procedures described in (WP 0016 00). Specific areas described below need to be cleaned after an operational event or periodically if stored/staged outside of a fixed facility to keep the container, modules, and accessories performing as designed. Cleaning also assists in maintaining the condition of the materiel stored within the system. Any damage discovered when cleaning and/or lubricating that cannot be corrected using the troubleshooting procedures described in (WP 0014 00) should be reported to maintenance for corrective action.

Table 1 Cleaning

SURFACE	OIL/GREASE	SALT/MUD/DIRT DEBRIS	RUST/CORROSION
Exterior and Interior Walls (All)	Detergent, Water, Rags	Soapy Water, Brush, Rags	Corrosion Removal Compound and Wire Brush, Dry Rag, Coat with Lube Oil or Spot Paint
Door Seals	Damp and Dry Rags	Damp and Dry Rags	N/A
Module Cradles, Container Floor	Detergent, Water, Rags (Remove, clean, and replace rubber pad into footing)	Soapy Water, Brush, Rags (Remove, clean and replace rubber pad into footing)	Corrosion Removal Compound and Wire Brush, Dry Rags, Coat with Lube Oil or Spot Paint (Remove, clean, and replace rubber pad into module cradle footing)
Container Door Hinges	N/A	Brush, Rag and lubricate as needed to ensure door hinges travel freely	Corrosion Removal Compound and Wire Brush, Dry Rags and Lubricate as needed
Door Retaining Straps	Detergent, Water, Rags	Detergent, Water, Rags	N/A
Pallet Ledge Locking Rod	N/A	Brush, Rag and lubricate as needed to prevent rust buildup on threads	Corrosion Removal Compound and Wire Brush, Dry Rags and Lubricate as needed

Table 1 Cleaning (continued)

SURFACE	OIL/GREASE	SALT/MUD/DIRT DEBRIS	RUST/CORROSION
Module Door Hinges	N/A	Brush, Rag and lubricate as needed to ensure door hinges travel freely	Corrosion Removal Compound and Wire Brush, Dry Rags and Lubricate as needed
Module Side Spark Prevention Bumper strips	Detergent, Water, Rags	Soapy Water, Brush, Rags	Do Not Paint
Module Weather Covers	Detergent, Water, Rags	Soapy Water, Brush, Rags	Do Not Paint
End of Table 1 Cleaning			

Table 2 Lubrication

USAGE	FLUID or LUBRICANT	CAPACITIES	EXPECTED TEMPERATURES	INTERVAL
Door Hinges	General Purpose Lubricating Oil 10W	As Required	All Temperatures	Monthly or as required if under adverse conditions
Door Cam Locks	Molykote Multipurpose Synthetic Grease P/N 26040124	As Required	All Temperatures	Monthly or as required if under adverse conditions
Door Seals	Molykote Multipurpose Synthetic Grease P/N 26040124	As Required	All Temperatures	Monthly or as required if under adverse conditions
Door Lock Shaft Pivot Bearing	Molykote Multipurpose Synthetic Grease P/N 26040124	As Required	All Temperatures	Monthly or as required if under adverse conditions
Folding Steps	General Purpose Lubricating Oil 10W	As Required	All Temperatures	Monthly or as required if under adverse conditions
Pallet Ledge Rear Cam Lock	General Purpose Lubricating Oil 10W	As Required	All Temperatures	Monthly or as required if under adverse conditions
Pallet Ledge Locking Rod	Molykote Multipurpose Synthetic Grease P/N 26040124	As Required	All Temperatures	Monthly or as required if under adverse conditions

Table 2 Lubrication (continued)

USAGE	FLUID or LUBRICANT	CAPACITIES	EXPECTED TEMPERATURES	INTERVAL
Snap Hooks Safety Device on Ratchet Straps and Floor Nets	General Purpose Lubricating Oil 10W	As Required	All Temperatures	Monthly or as required if under adverse conditions
Module Drawer Slides and Container Parts Storage Aids Drawer Slides	Molykote Multipurpose Synthetic Grease P/N 26040124	As Required	All Temperatures	Bi-annually or as required if under adverse conditions
Container Storage Aids Drawer Locking Mechanism Tabs	Molykote Multipurpose Synthetic Grease P/N 26040124	As Required	All Temperatures	Monthly or as required if under adverse conditions
Drawer latches	General Purpose Lubricating Oil 10W	As Required	All Temperatures	Monthly or as required if under adverse conditions
Module Drawer Slam Locks	Molykote Multipurpose Synthetic Grease P/N 26040124	As Required	All Temperatures	Monthly or as Required if under Adverse Conditions
Non-Metallic Snap Hook Straps for Nets	N/A	As Required	All Temperatures	Monthly or as required if under adverse conditions
Removable Cradle Twist Lock	Molykote Multipurpose Synthetic Grease P/N 26040124	As Required	All Temperatures	Monthly or as Required if under Adverse Conditions
Removable Cradle Locking Rod Pivot	Molykote Multipurpose Synthetic Grease P/N 26040124	As Required	All Temperatures	Monthly or as Required if under Adverse Conditions
Bulk Module Bin Latches	General Purpose Lubricating Oil 10W	As Required	All Temperatures	Monthly or as required if under adverse conditions
End of Table 2 Lubrication				

END OF WORK PACKAGE

This page was intentionally left blank

OPERATOR MAINTENANCE INSTRUCTIONS**FPU® SYSTEMS OPERATION MANUAL
(INCLUDING REPAIR PARTS)
EXPEDITIONARY CONTAINERIZED AUTHORIZED STOCKAGE LIST (ECASL)
BOH FPU Field Pack-up Units****FPU-20-3 DOORS**

INITIAL SETUP:**Materiel/Parts**

None

Personnel Required

One

Tools

Ladder with hand rail

References

Chapter 2 WP 0006 00-1 to 00-7

Equipment ConditionECASL SYSTEM Setup

INSPECT

1. Open and close right door (A), left door (B), refer to chapter 2 pages 0006 00-1 through 00-7 to ensure proper operation and alignment.
2. Visually inspect door seals for damage.
3. Inspect for missing door straps.



WARNING

The containers must be operated on level ground and periodically be checked for shifting from a level position. Use care when opening doors or drawers; physical injury may occur. To maintain control, consider the ground surface conditions for adequate traction, such as mud, snow, ice and sand.

CAUTION

The right door (A) must lead the left door (B) slightly when closed to prevent damage to the door edge seals.

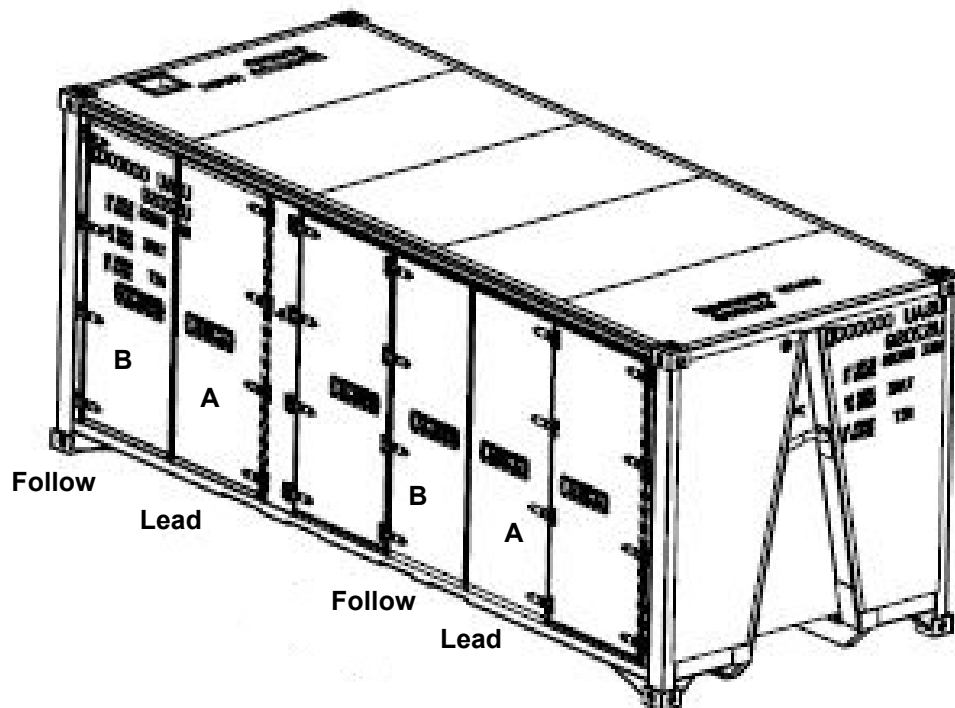

4. Notify maintenance of any missing or damaged seals and any problems with operation of latch, handle, or hinges for service.
5. Notify maintenance of any problems with door alignment.

END OF WORK PACKAGE

OPERATOR MAINTENANCE INSTRUCTIONS

FPU® SYSTEMS OPERATION MANUAL (INCLUDING REPAIR PARTS) EXPEDITIONARY CONTAINERIZED AUTHORIZED STOCKAGE LIST (ECASL) BOH FPU Field Pack-up Units

FPU-20-3 FOLDING STEPS

INITIAL SETUP:

Material/Parts

None

Personnel Required

One

References

Chapter 2 WP 0005 00-2 to 00-4

Equipment Condition

ECASL SYSTEM Setup

INSPECT

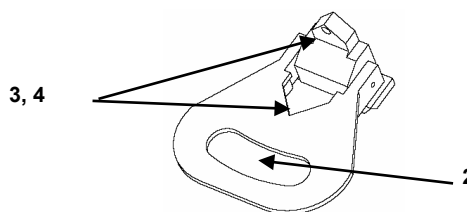
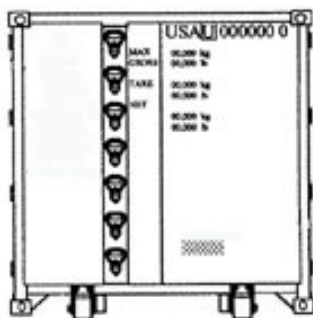

1. Raise and lower each of the steps (2) to ensure they stow and operate properly.
2. Inspect for missing ground lug (4).
3. Notify maintenance of missing, cracked, broken or poorly operating steps (2).
4. Notify maintenance of any cracked, broken or missing hardware (3).
5. Ensure that there is a ground lug (4) present.

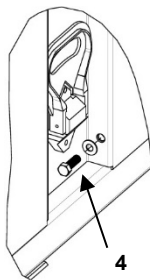

END OF WORK PACKAGE

This page was intentionally left blank

OPERATOR MAINTENANCE INSTRUCTIONS

FPU® SYSTEMS OPERATION MANUAL (INCLUDING REPAIR PARTS) EXPEDITIONARY CONTAINERIZED AUTHORIZED STOCKAGE LIST (ECASL) BOH FPU Field Pack-up Units

PARTS/BULK STORAGE AID VERTICAL RACK FRAME

INITIAL SETUP:

Materiel/Parts

None

Personnel Required

One

References

Chapter 2 WP 0007 and 0008

Equipment Condition

ECASL SYSTEM Set-up

INSPECT

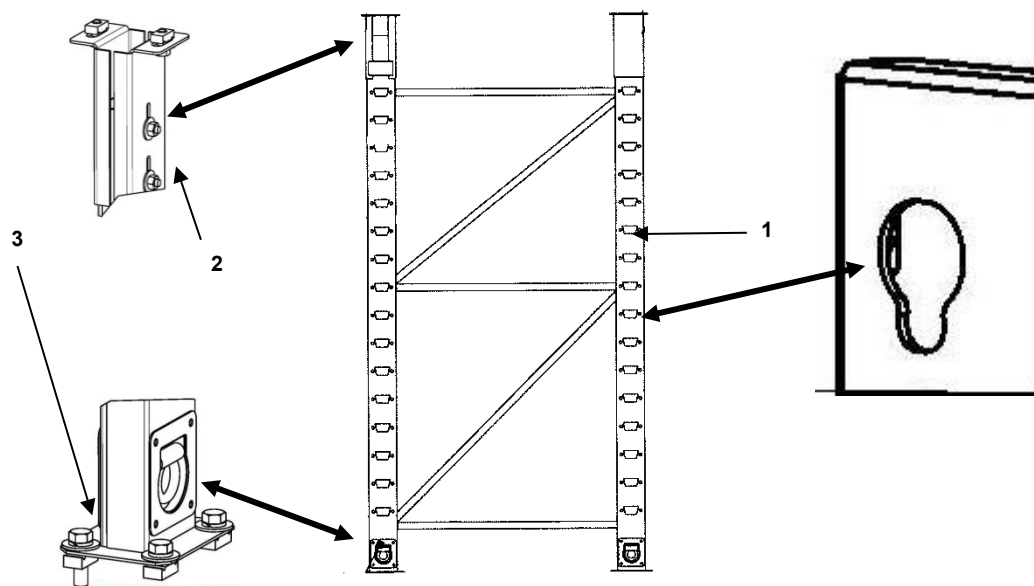

1. Inspect the vertical rack frame (1) for cracks, excessive dents or bending. Report to maintenance for repair or replacement.
2. Inspect vertical rack upper attachment (2) and lower attachment assemblies (3) for cracks, excessive dents or bending. Report to maintenance for repair or replacement.
3. Inspect vertical rack frame for damaged or missing bolts (2) & (3).
4. Report damage to maintenance for repair.

END OF WORK PACKAGE

This page was intentionally left blank

OPERATOR MAINTENANCE INSTRUCTIONS

FPU® SYSTEMS OPERATION MANUAL (INCLUDING REPAIR PARTS) EXPEDITIONARY CONTAINERIZED AUTHORIZED STOCKAGE LIST (ECASL) BOH FPU Field Pack-up Units

BULK STORAGE AID PALLET

INITIAL SETUP:

Material/Parts

None

Personnel Required

One

References

Chapter 2 WP 0007

Equipment Condition

ECASL SYSTEM Setup

INSPECT

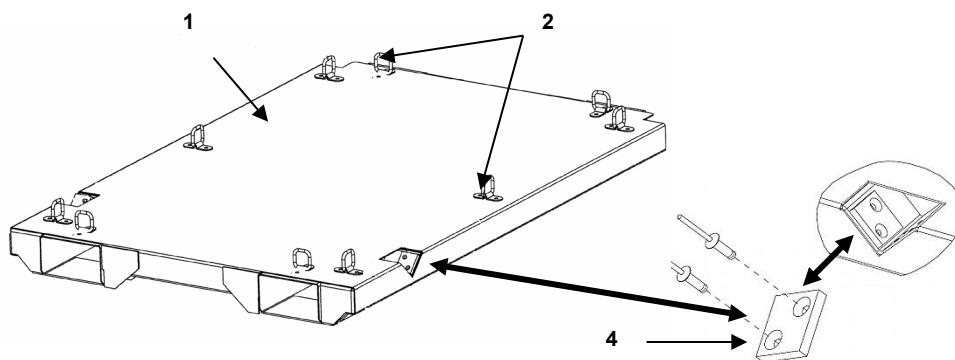

1. Inspect pallet (1) for cracks, excessive dents or sagging, report damage to maintenance for repair or replacement.
2. Inspect for damaged or missing nets (3), replace damaged nets (3).
3. Inspect pallet for missing or damaged D-rings (2). Report damage to maintenance for repair or replacement.
4. Inspect for missing or damaged pallet lock pads (4). Report damage to maintenance for repair or replacement.

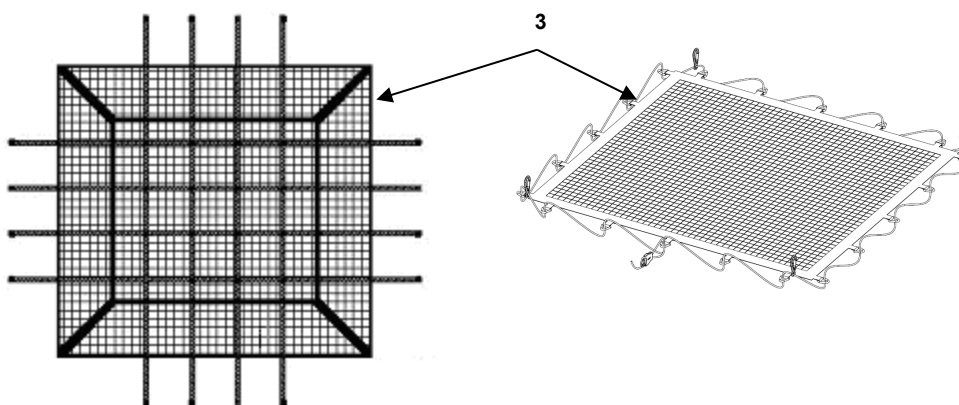

END OF WORK PACKAGE

This page was intentionally left blank

OPERATOR MAINTENANCE INSTRUCTIONS**FPU® SYSTEMS OPERATION MANUAL
(INCLUDING REPAIR PARTS)
EXPEDITIONARY CONTAINERIZED AUTHORIZED STOCKAGE LIST (ECASL)
BOH FPU Field Pack-up Units****BULK STORAGE AID PALLET LEDGE****INITIAL SETUP:****Materiel/Parts**

None

Personnel Required

One

References

Chapter 2 WP 0007

Equipment Condition

ECASL SYSTEM Set-up

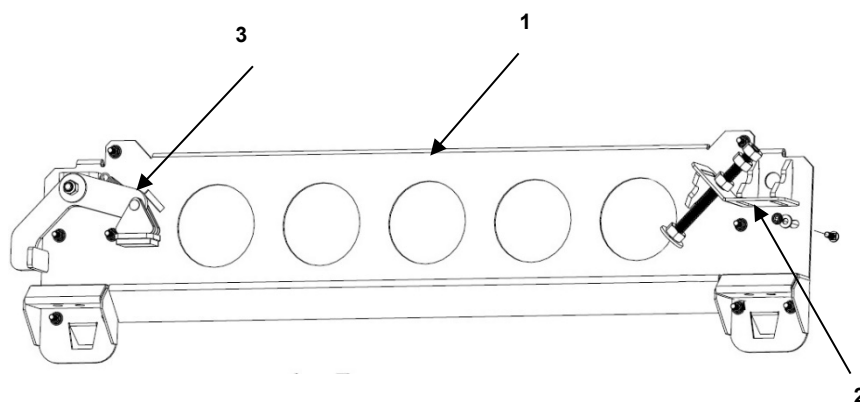
INSPECT

1. Remove pallet from container using a forklift.
2. Inspect pallet ledges (1) for operation of Cam Locks (2), Lock Rods (3), and missing hardware.
3. Inspect pallet ledges for dirt/debris that would affect performance.
4. Clean and lubricate as required, see chapter 4 WP 0017 00.

END OF WORK PACKAGE

This page was intentionally left blank

OPERATOR MAINTENANCE INSTRUCTIONS

FPU® SYSTEMS OPERATION MANUAL (INCLUDING REPAIR PARTS) EXPEDITIONARY CONTAINERIZED AUTHORIZED STOCKAGE LIST (ECASL) BOH FPU Field Pack-up Units

STANDARD STORAGE MODULES

INITIAL SETUP:

Material/Parts

None

Personnel Required

One

Tools

None

References

WP 0010 00

Equipment Condition

ECASL SYSTEM Setup

INSPECT

1. Open and close drawer assemblies. Follow steps outlined in WP 0010 00-7 to ensure proper operation and alignment. Lubricate, repair or replace as needed.
2. Inspect slam latches (1) for smooth movement, spring tension and retention of the drawer in the fully closed position. Notify unit maintenance of any missing or damaged slam latches.
3. Inspect for missing or damaged side bumper strips (2). Notify unit maintenance of any missing or damaged spark suppression bumper strips.

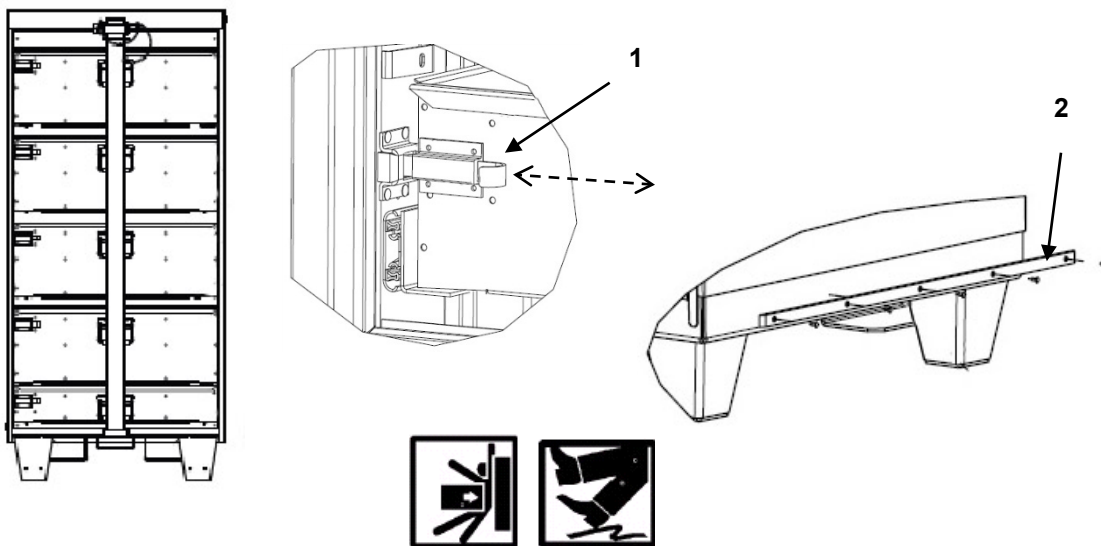

WARNING

The modules must be operated on level ground and periodically checked for shifting from a level position in or out of the containers. To maintain control, consider the ground surface conditions for adequate traction, such as mud, snow, ice and sand.

END OF WORK PACKAGE

This page was intentionally left blank

OPERATOR MAINTENANCE INSTRUCTIONS

FPU® SYSTEMS OPERATION MANUAL (INCLUDING REPAIR PARTS) EXPEDITIONARY CONTAINERIZED AUTHORIZED STOCKAGE LIST (ECASL) BOH FPU Field Pack-up Units

BULK STORAGE MODULE

INITIAL SETUP:

Material/Parts

Rags, light lube oil

Personnel Required

Two

Tools

¾" Open End and ¾" Socket Wrench

References

Chapter 2 WP 0009

Equipment Condition

ECASL SYSTEM Setup

INSPECT

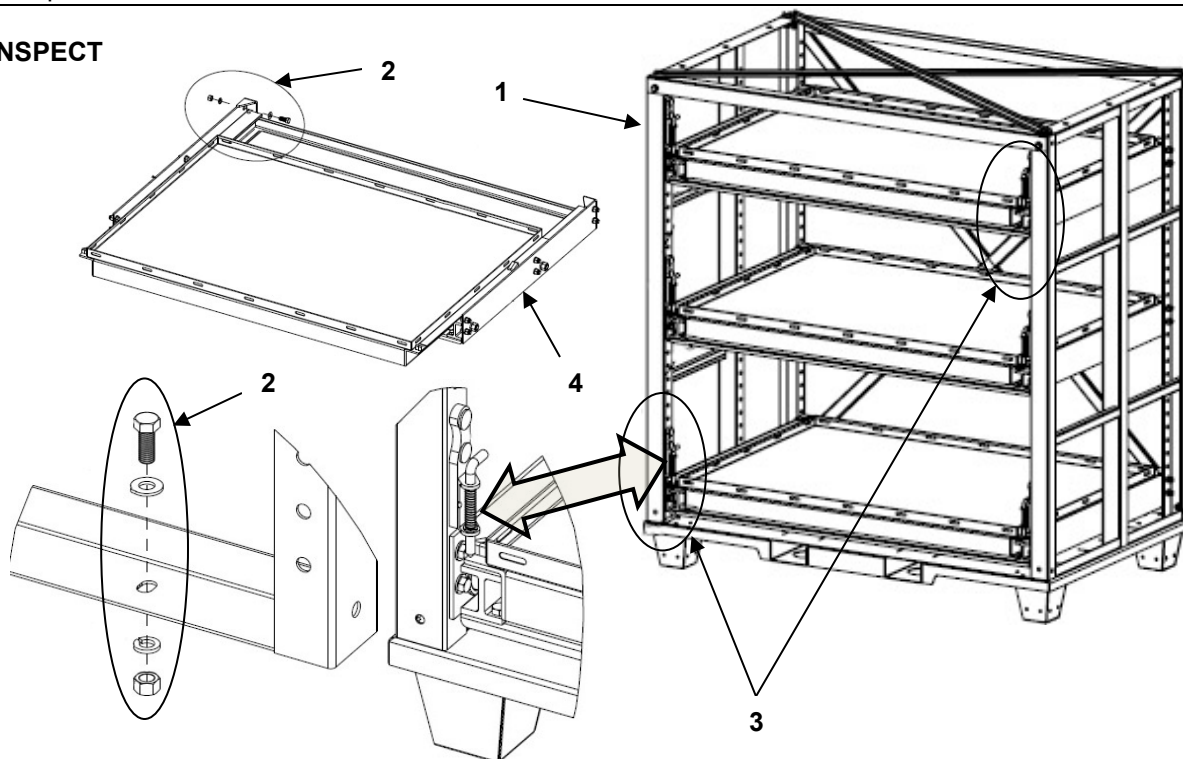

1. Inspect hull (1) for loose or missing hardware.
2. Tighten loose hardware (2) with a ¾" open end wrench and ¾" socket wrench.
3. Replace missing hardware.
4. Inspect each left and right locking latch bolts and springs for smooth operation (3); see chapter 2 WP 0009 00-4.
5. Inspect the roller shelves (4) for ease of operation. Review WP 0009 00-7 for operation.
6. Inspect inside surface of roller shelf tracks (4) for dirt or rust. Clean and apply light oil and wipe off excess.
7. Test locking latch bolts and springs for proper operation, see chapter WP 0009 00-4. Clean and lubricate as needed.

NOTE

Tray and frame hardware (2) are common throughout the module.

NOTE

Shelf roller bearings do not require lubrication. Lubrication will only attract dirt and sand.

Shelf Stop Bolts (Safety Check)

8. Check shelves for all four Stop Bolts front and rear (1) and (2).



WARNING

Always ensure that all four of the front (1) and rear (2) stop bolts are in place. This will prevent the shelves from rolling out of the hull. Failure will result in damage, injury or death.

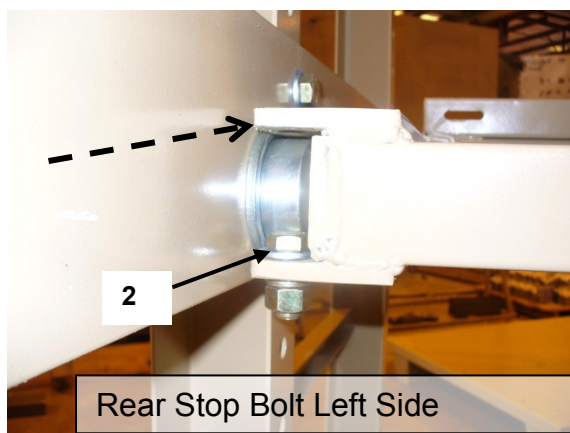
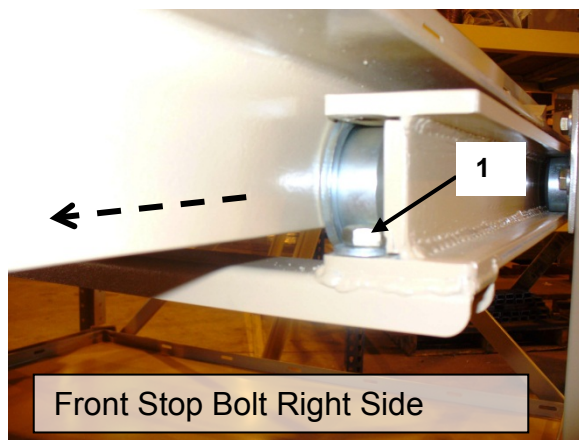
**Note**

Only remove the stop bolts when a shelf is empty or removing a shelf to reposition a shelf.

END OF WORK PACKAGE