

**FPU® SYSTEMS OPERATION MANUAL  
(INCLUDING REPAIR PARTS & SPECIAL TOOL LIST)  
STANDARD AND SPECIALIZED FPU MODULES  
BOH FPU Field Pack-up Units**

**CHAPTER 2  
OPERATOR INSTRUCTIONS**

This page was intentionally left blank

## OPERATOR INSTRUCTIONS

### FPU SYSTEMS OPERATION MANUAL (INCLUDING REPAIR PARTS & SPECIAL TOOL LIST) STANDARD AND SPECIALIZED FPU MODULES BOH FPU Field Pack-up Units

#### OPERATION OF FPU STANDARD STORAGE MODULES

#### BOH FPU STANDARD PARTS MODULES

#### NOTE

The FPU Module system does not apply to the BOH-CARGO-6 BULK CARGO container.



#### STANDARD PARTS MODULES

BOH Environmental currently offers six classes (variations) of standard shipping/storage modules for the shipping/storage of small, intermediate and bulk parts. Modules measure 74" (H) x 34"(W) x 42"(D) and are capable of holding a cross section of drawers from 4" to 16" in depth. These drawers have a design-rated capacity from 200 to 400 lbs depending on drawer size. All drawers are full extension (40-inches) and allow full access to stowed material. Drawers are adjustable in 3-inch increments. Small to intermediate parts storage/shipping modules are available with 4-inch, 6-inch, 8-inch, 10inch, 12-inch, and 16-inch deep drawers. Compartments are adjustable in 2" increments from front to back and vary side to side depending on the drawer size. Maximum drawer compartments in standard shipping/storage modules range from 125 to 920. All modules are designed to be interchangeable; therefore, they may be inserted into the FPU-8 and FPU-20 series containers.

#### STANDARD PARTS MODULE CLASSES

There are 19 style variations of the 6 classes of standard module with one unique short/HELO module with basket (see WP 0006 00). The 6 classes are illustrated on the following pages 0005 00-3 through 0005 00- 9 by class.

#### NOTE

All Modules are provided with non-metallic side and rear bumper strips (1) to prevent metal to metal contact during loading operations.

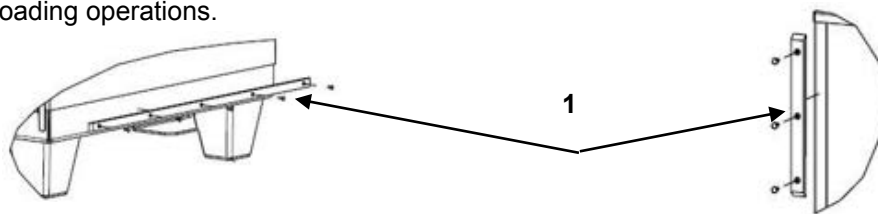

0005 00-1

### Module Data Tag Location

The module data tag (1) is located at the rear bottom right corner of the module (2).

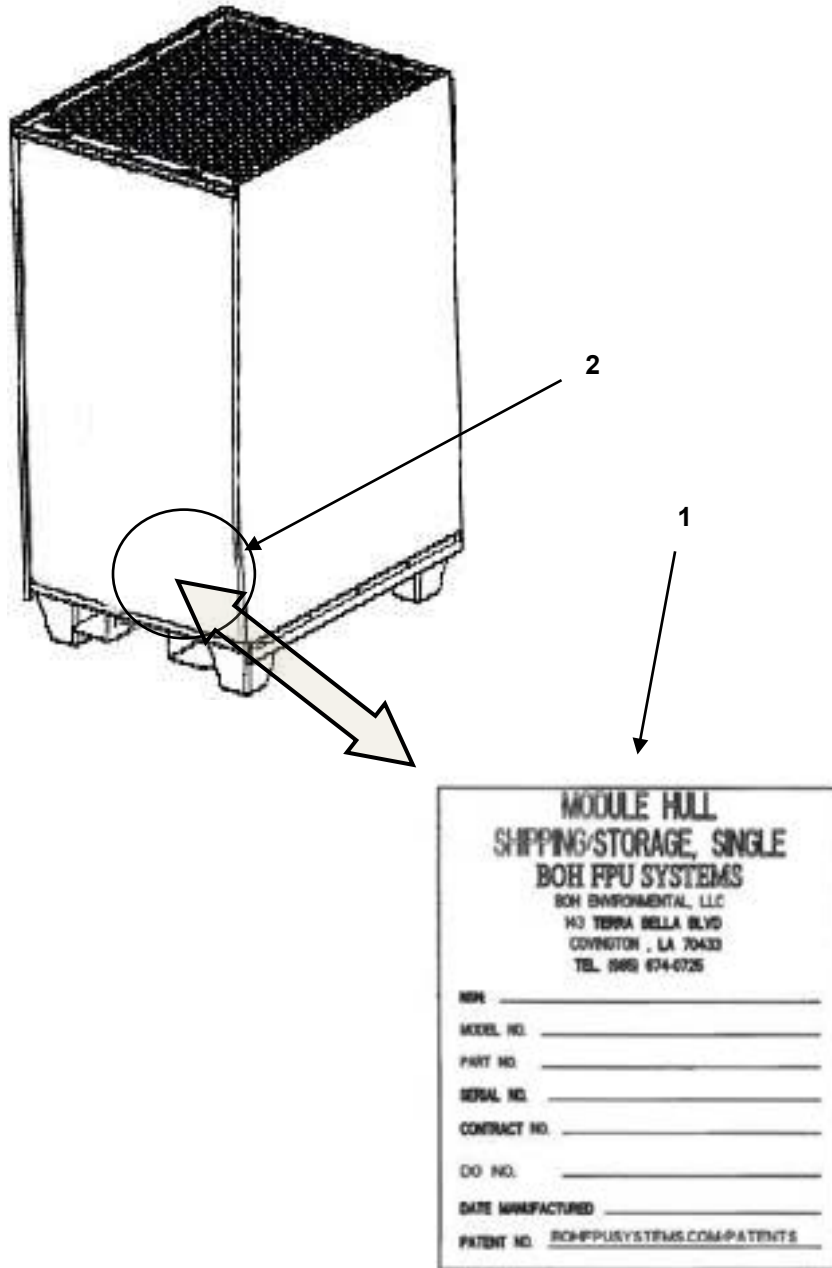

**CLASS 1 PARTS MODULES**

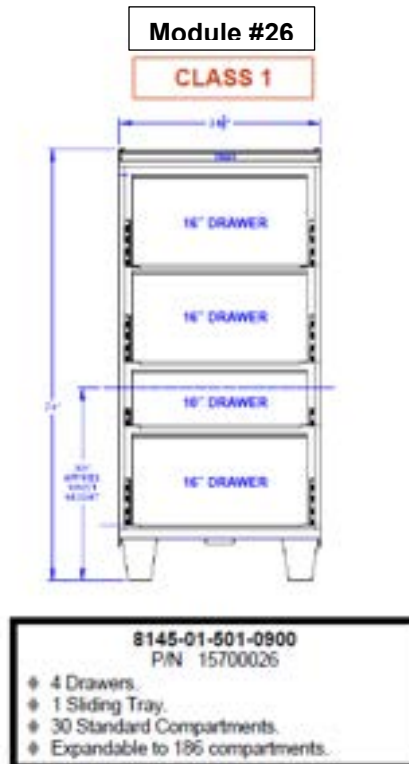
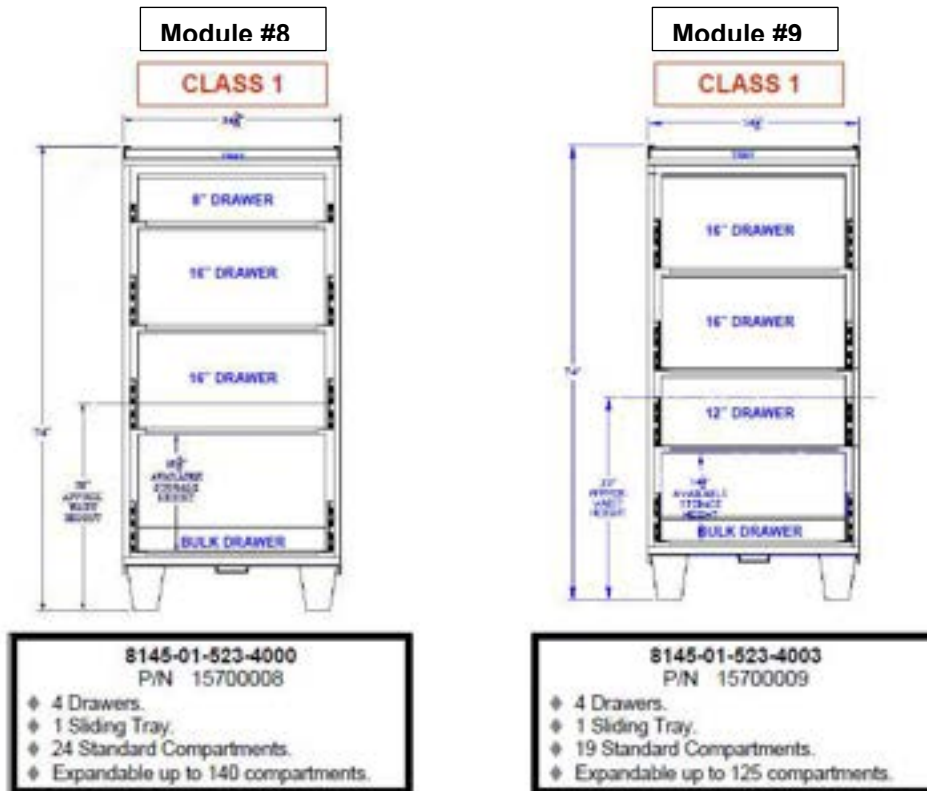

**CLASS 2 PARTS MODULES**

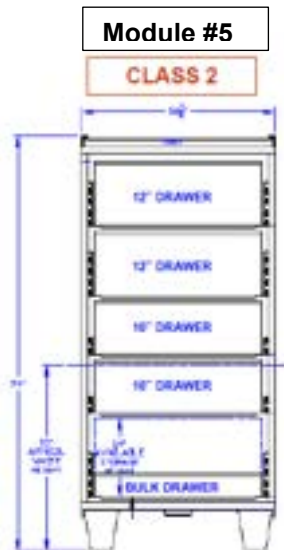

**Module #5**  
**CLASS 2**  
 8145-01-523-4005  
 P/N 15700005  
 ♦ 5 Drawers.  
 ♦ 1 Sliding Tray.  
 ♦ 37 Standard Compartments.  
 ♦ Expandable to up to 201 compartments.

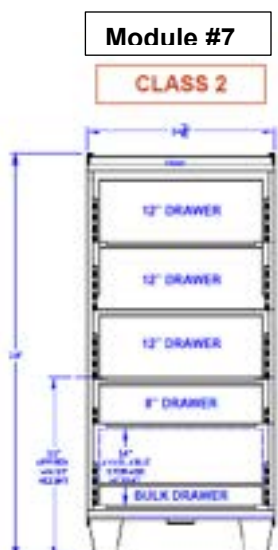

**Module #7**  
**CLASS 2**  
 8145-01-501-0866  
 P/N 15700007  
 ♦ 5 Drawers.  
 ♦ 1 Sliding Tray.  
 ♦ 31 Standard Compartments.  
 ♦ Expandable up to 180 compartments.

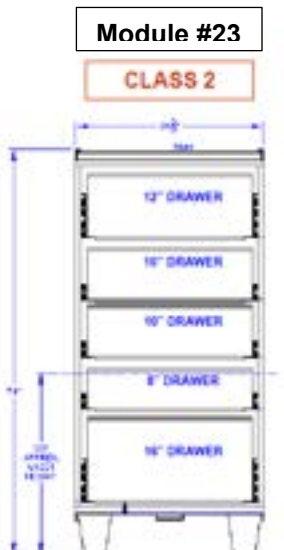

**Module #23**  
**CLASS 2**  
 8145-01-523-4011  
 P/N 15700023  
 ♦ 5 Drawers.  
 ♦ 1 Sliding Tray.  
 ♦ 48 Standard Compartments.  
 ♦ Expandable to 262 compartments.

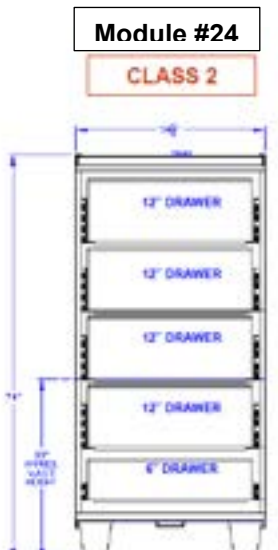

**Module #24**  
**CLASS 2**  
 8145-01-501-0892  
 P/N 15700024  
 ♦ 5 Drawers.  
 ♦ 1 Sliding Tray.  
 ♦ 36 Standard Compartments.  
 ♦ Expandable to 220 compartments.

## CLASS 2 PARTS MODULES

Module #25

CLASS 2

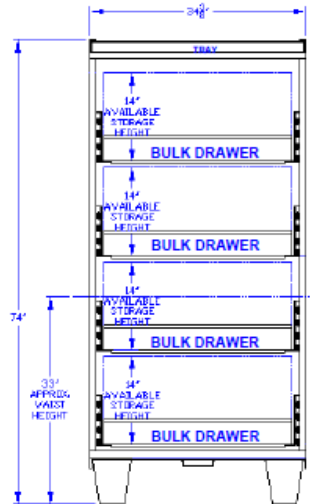

8145-01-501-0896  
P/N 15700025

- ◆ 4 Bulk Drawers.
- ◆ 1 Sliding Tray.

**CLASS 3 PARTS MODULES**

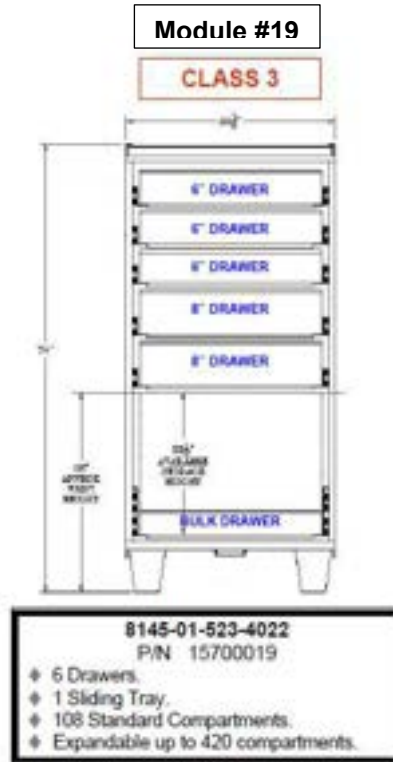
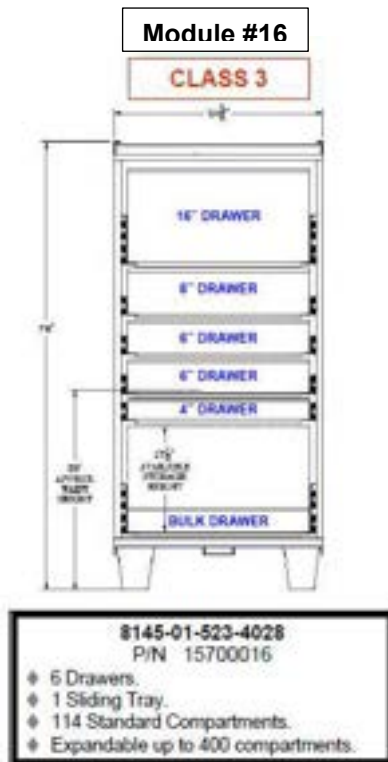
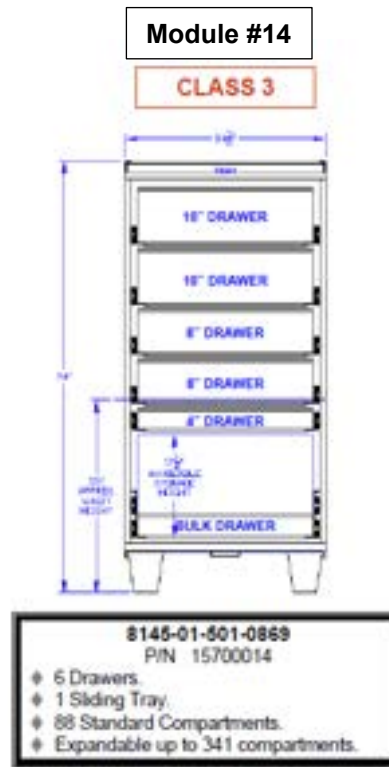
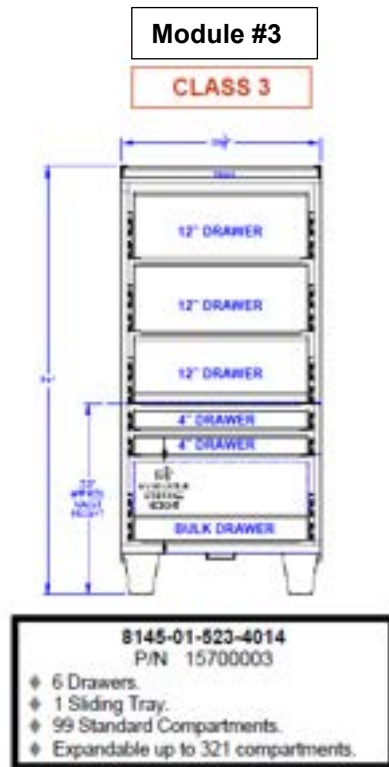

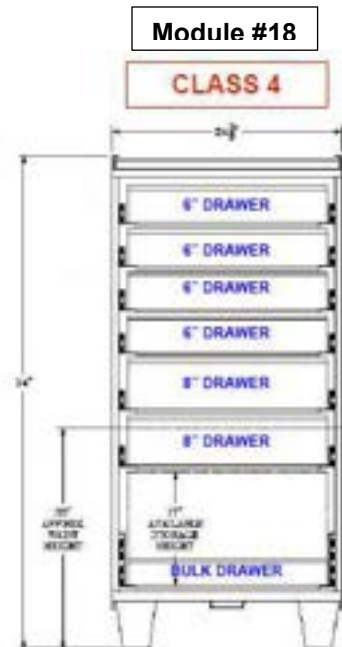

**CLASS 4 PARTS MODULE**

8145-01-523-4025  
P/N 15700018

- ◆ 7 Drawers.
- ◆ 1 Sliding Tray.
- ◆ 136 Standard Compartments.
- ◆ Expandable to 520 compartments.

0005 00-7

**CLASS 5 PARTS MODULES**

**Module #11**

**CLASS 5**

**8145-01-522-0667**  
 P/N 15700011

- ◆ 8 Drawers.
- ◆ 1 Sliding Tray.
- ◆ 211 Standard Compartments.
- ◆ Expandable up to 641 compartments.

**Module #13**

**CLASS 5**

**8145-01-501-0868**  
 P/N 15700013

- ◆ 8 Drawers.
- ◆ 1 Sliding Tray.
- ◆ 208 Standard Compartments.
- ◆ Expandable to 700 compartments.

**Module #20**

**CLASS 5**

**8145-01-523-4039**  
 P/N 15700020

- ◆ 7 Drawers.
- ◆ 1 Sliding Tray.
- ◆ 154 Standard Compartments.
- ◆ Expandable to 560 compartments.

**Module #22**

**CLASS 5**

**8145-01-523-4040**  
 P/N 15700022

- ◆ 8 Drawers.
- ◆ 1 Sliding Tray.
- ◆ 192 Standard Compartments.
- ◆ Expandable to 720 compartments.

## CLASS 6 PARTS MODULES

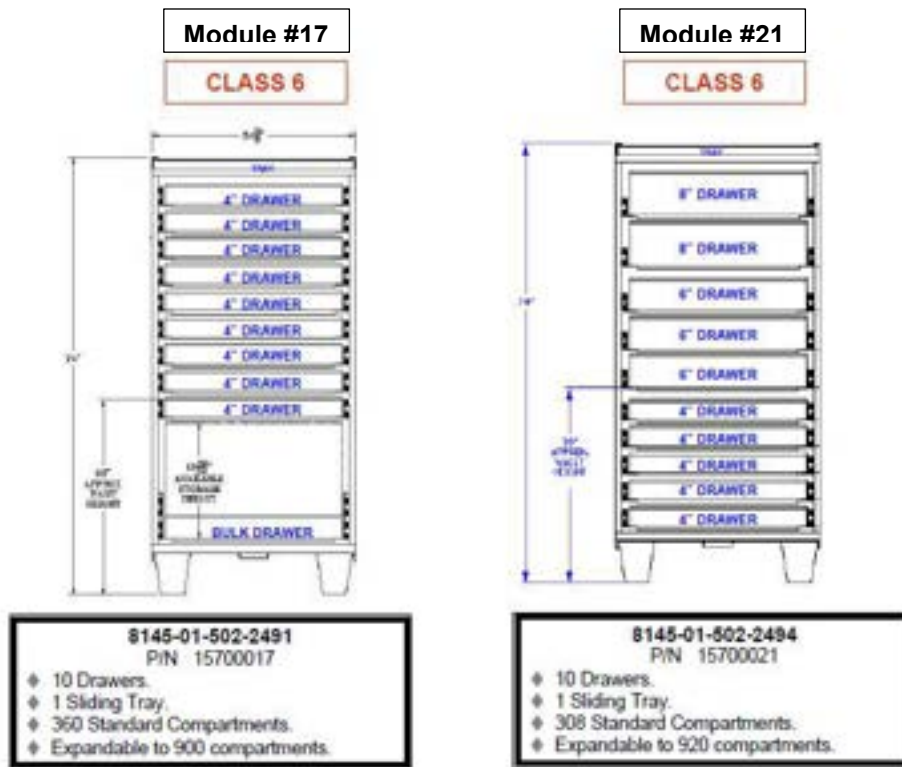

**MODULE TOP LOW PROFILE BULK PAN**

Each Standard module, with exception of the Short HELO module, has a recessed bulk material, area on the top of the module with a restraint net (1).

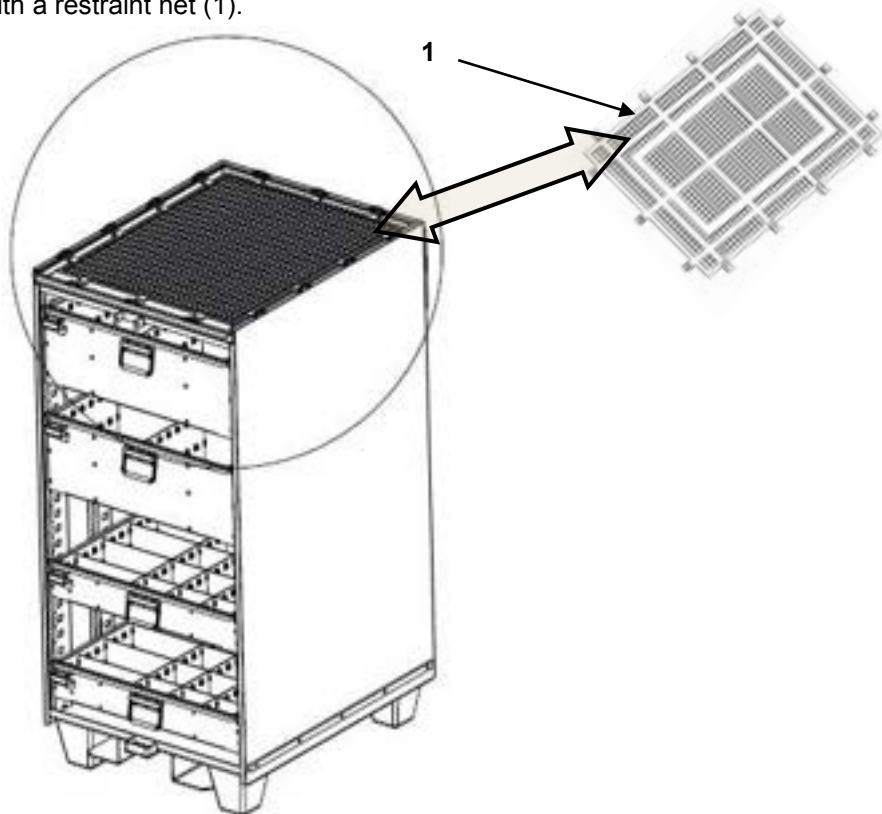

**CAUTION**

Always consider the container loading and lifting clearance (3) before loading any modules with material.

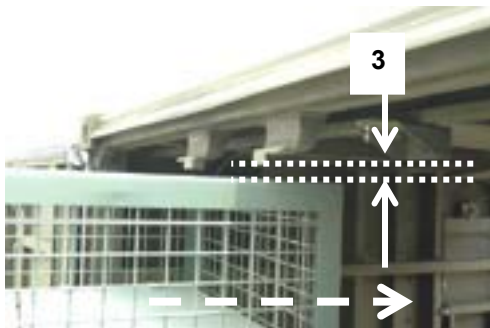

**WARNING**



Keep clear and do not attempt to push material down while the module is being loaded.

## MODULE DRAWERS

There are various prescribed divider sets provided with each size standard module drawer. The drawer divided segments can be customized with additional optional sets of dividers.

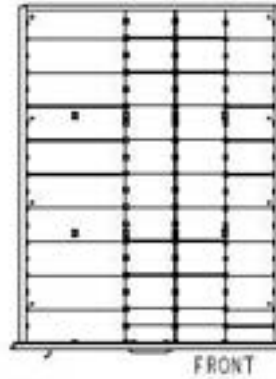

ALT. DRAWER  
CONFIGURATION

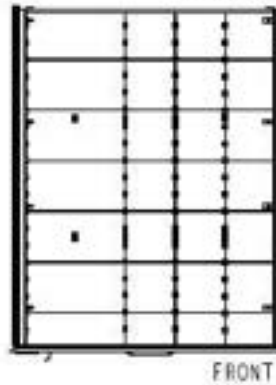
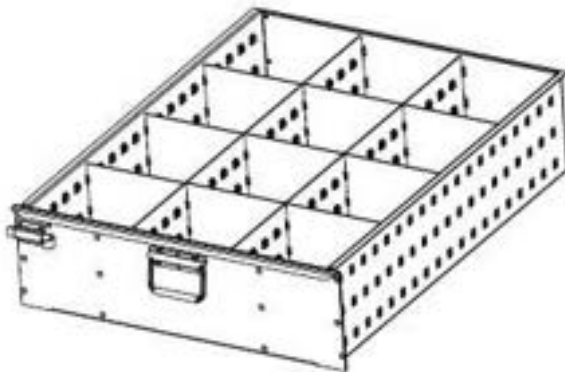

STANDARD DRAWER  
CONFIGURATION

The drawer segments can be easily enlarged or reduced by simply adding or removing dividers.

## THE FOUR INCH DRAWER COVERS

There are two versions of the 4" drawer lid to provide debris control and containment of very small parts during shipment. The sliding lid version (1) slides over the drawer from the front and covers all the dividers. An older folding lid version (2) is double hinged and has a support rod (3) located underneath each side. When the lid is raised the rod supports the lid for easy access to the material.

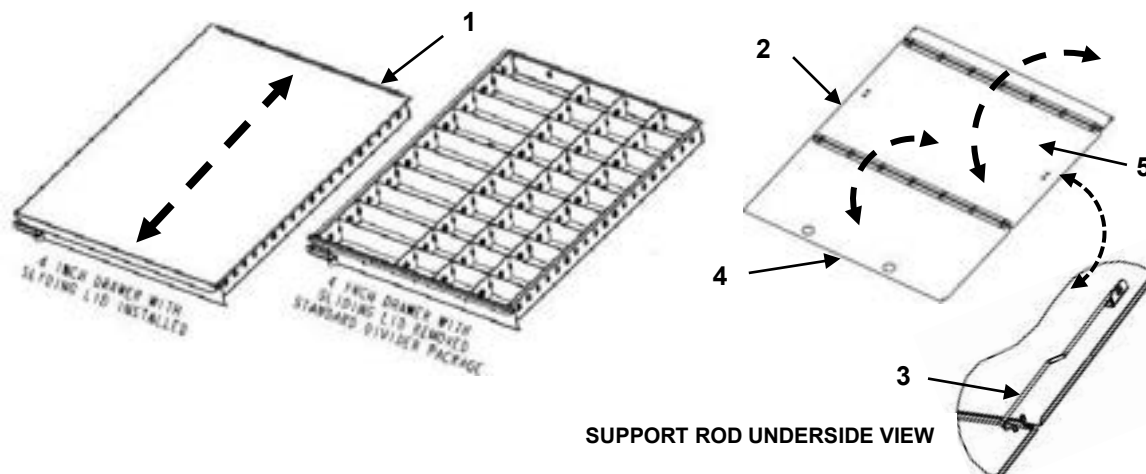

### Note

The folding 4" drawer lid is an older version and is available, CAGE 1NSG3 P/N16020424

### Opening Folding Lid Cover

1. Grasp the front portion of the lid (4) by the two front finger holes and lay it back onto the rear lid portion (5).
2. Grasp the front edge of the rear lid portion (5) and raise it until the support rods (3) are engaged and the lid (2) is supported in the fully open position.



There is a 4" bulk drawer version with a net (6) secured through the use of footman loops (7) around the edge of the drawer.

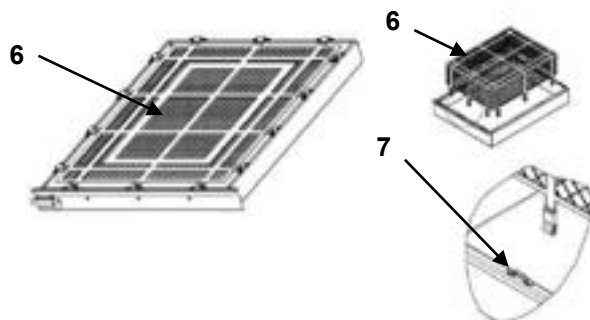

0005 00-12

## DRAWER REPLACEMENT

Although the standard modules come in prescribed drawer configurations, there are optional drawers of various sizes that can replace the existing configuration.

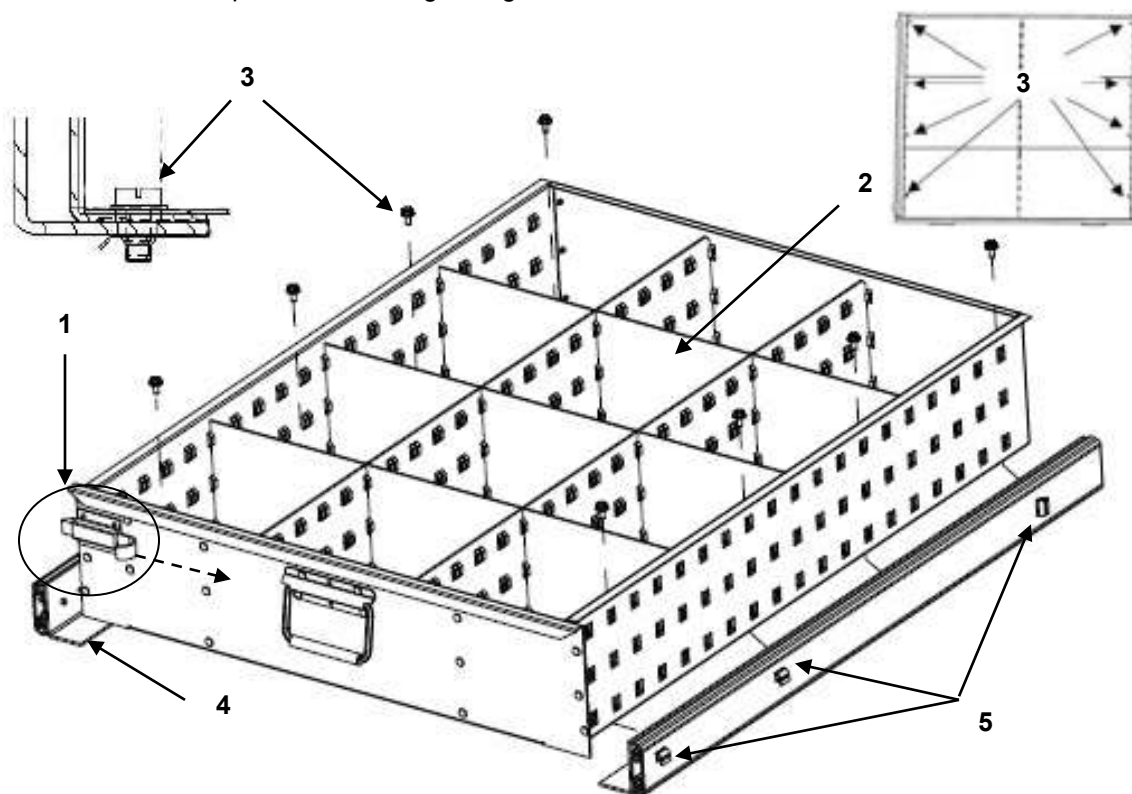

### Drawer Removal

1. Release the slam latch (1) on the left side of the drawer.
2. Pull the drawer to the full out position.
3. Remove the material and divider set (2).
4. Remove the eight cap screws (3) on the interior of the drawer with the 7/16" socket wrench.
5. Lift the drawer from the bearing sliders (4).
6. Remove the two set screws that secure the slide to the module housing.
7. Use a block of wood and hammer to tap the sliders (4) up to disengage the tabs (5) and cleats.

### Bearing Drawer Slides

The drawers are attached to the roller slides (4) by means of auto thread clips (6) and screws (3).



0005 00-13

There are two sizes of drawer slides, a single roller and double rollers (1) for the large drawers.

### Note

The drawer slides (1) come in left and right pairs as part of a drawer replacement kit and are matched to the drawer size.

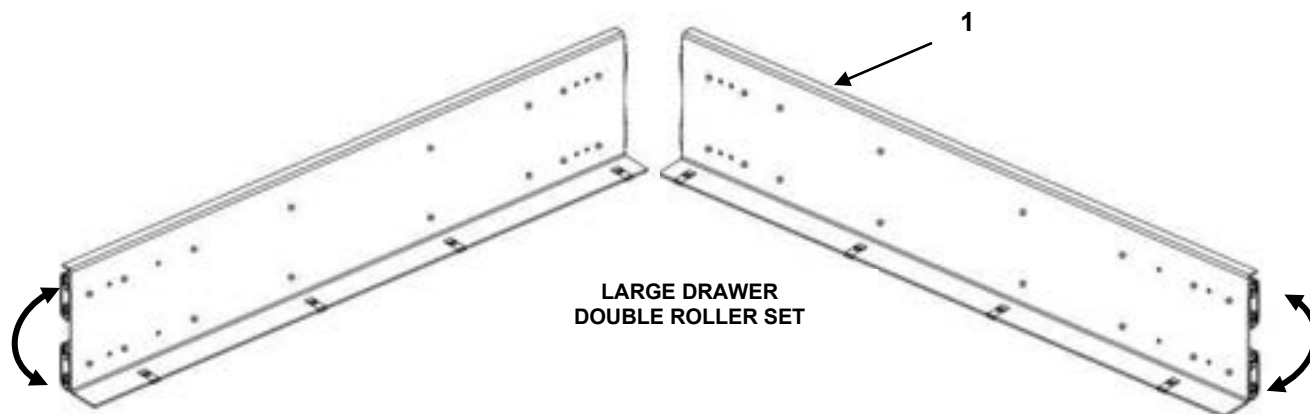

### To attach the drawer slide

1. Align the three sets of tabs on the back of the slide and tab holes in the three uprights.
2. Tap the slide down with a block of wood until the slide is level and secure within the tabs.
3. Install the two set screws that secure the slide (1) to the module housing.
4. Insert the drawer and tighten the eight cap screws with the 7/16" wrench.
5. Push the drawer to the full in position till the slam latch is engaged.

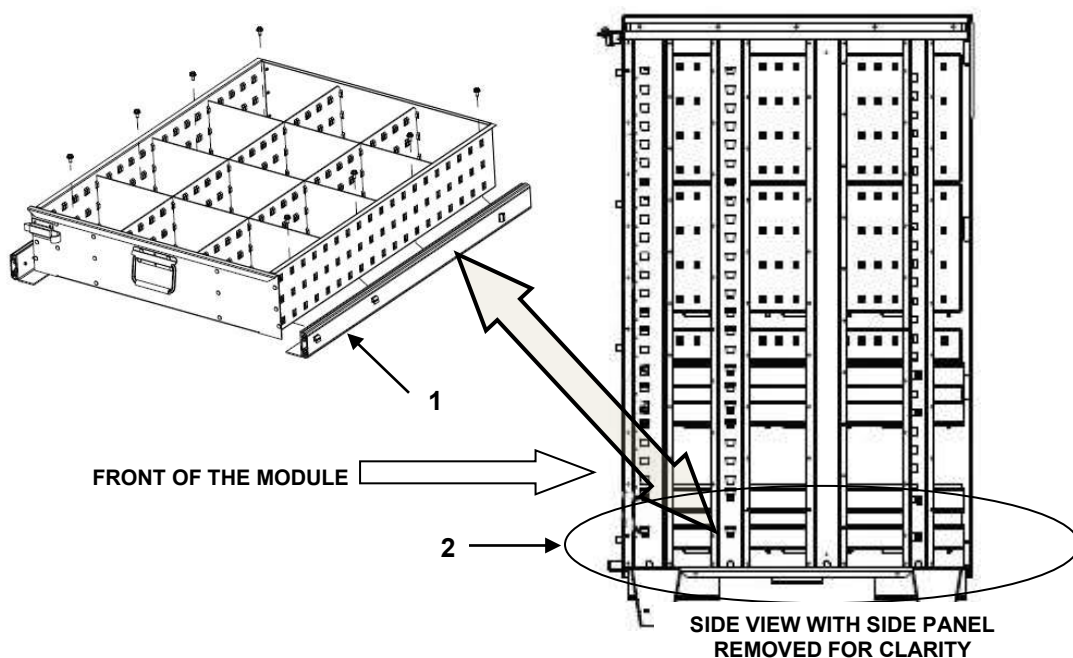

0005 00-14



## PADLOCK SECURITY BAR

All Standard Modules material drawers are retained by means of a pad lockable security bar.



All Standard and Specialized Modules may be secured within any FPU-8 or FPU-20 series containers by means of a removable cradle (1) and module locking arms (2).

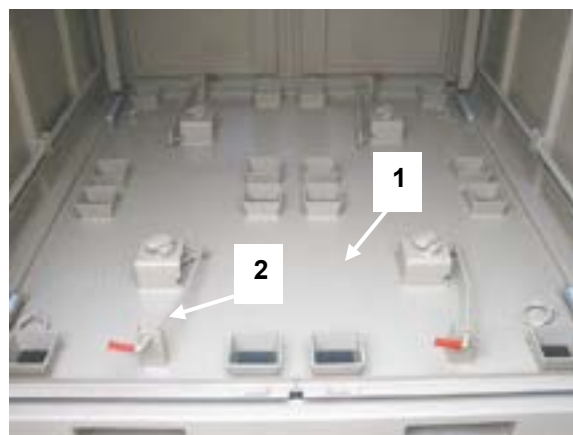
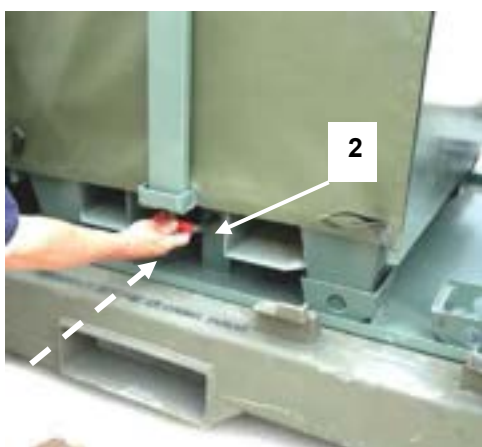

### CAUTION

Verify that the module is properly seated and the red handle on the module-locking arm (2) is pushed completely to its closed and locked position.

## STANDARD MODULE FRONT VINYL COVER

Each module is provided with a black vinyl weather protection fitted cover (1), for basic weather protection, attached by Velcro strips and removed by with nylon straps (2).

1. Place the cover (1) over the module front, attach with the hook and pile Velcro.

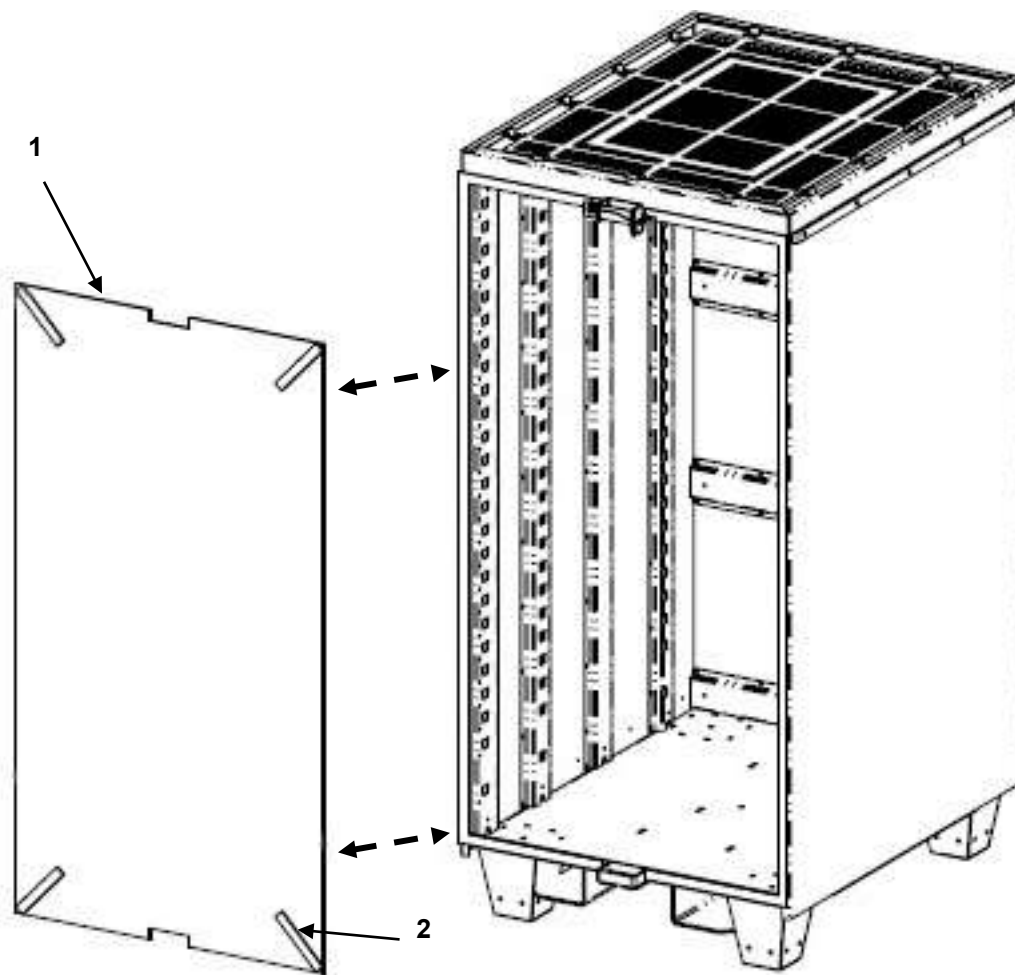

### Note

Drawers removed for clarity

## OPTIONAL VINYL WEATHER PROTECTION COVER

Optional black vinyl weather protection fitted cover (1) is attached by Velcro strips and adjustable nylon straps (2).

1. Place the cover (1) over the module. Fold over flap #1, then flap #2, then fold down flap #3 and adjust the straps (2).

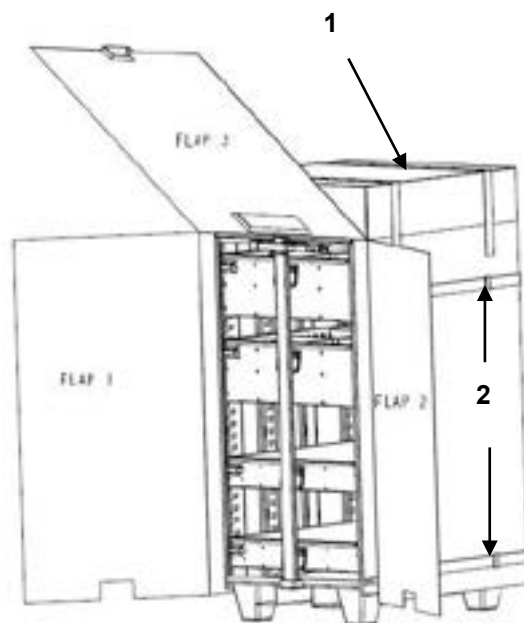

## Optional Module Casters

### NOTE

These casters (1) are not designed or intended to be used on the FPU Bulk Modules.

A set of casters (1), is available for ease of movement and positioning in a warehouse setting. The casters fit the Standard and specialized modules, mentioned in this manual.

These casters (1) are designed for concrete and other firm surfaces, and are not intended for dirt, sand, mud or snow.

### NOTE

The casters with foot brake pedals (3), should always be installed in the front of the module (2). This position provides access to the locking foot brake pedals (3) and access to the front of the module (2).

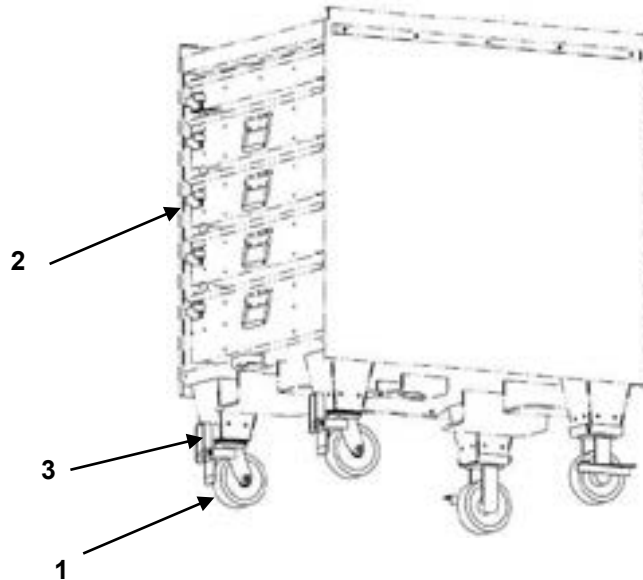

### WARNING



Never install these casters (1) in the FPU Bulk Module; the casters (1) would collapse under the extreme weight of the FPU Bulk Module load. Never attempt to roll a module with casters (1) up/down a ramp or incline. Failure to comply may cause injury, death or damage to the equipment.



## Installing the Casters

1. MHE support is required to install the casters into the module feet (1).
2. Forklift tines, should maintain approximately 18-inches between the forklift-bridge and module (2), to prevent interference installing the casters.
3. A ground guide must be present during this operation and direct all movement of the MHE.
4. Elevate the desired module (2) approximately 3 feet to gain access to the holes in the module feet (1).
5. Position the front caster with the foot brake pedal (5) facing the front of the module (2).
6. From the right side of the module, insert the front caster (3), until the base (4) mates with the bottom of the foot (1).
7. Position the rear caster (7), with the open flange, facing the rear of the module (2).
8. Insert the rear caster (7) with the base opening (6) facing the rear until the base mates with the module foot (1).
9. Proceed to the left side of the module (2) and repeat steps 1 through 8.
10. With the casters in place, lower the module (2) to the ground.
11. Disengage the forklift.
12. Test the brakes by depressing both foot pedals (5) and attempting to move the module (2).
13. The module (2) should not move.
14. Release the brakes by raising the foot pedals (5) and move the module (2).
15. When the module (2) is in the storage position, set both brakes by depressing the foot pedals (5).

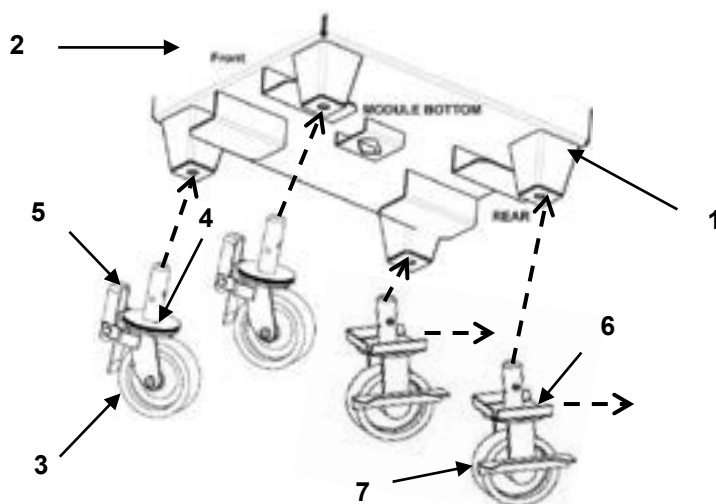

### WARNING



Standard MHE practices apply; a ground guide will direct all MHE movement. Always operate the modules with casters on a level firm surface. Never attempt to roll a module with casters up/down a ramp or incline. Failure to comply may cause injury, death or damage to the equipment. Failure to set the brakes on the casters may cause unwarranted movement and may cause injury, death or damage to the equipment.

### NOTE

The rigid casters (6) are no longer available as of February 2017. A module caster set will now include four swivel casters (3).

**END OF WORK PACKAGE**

0005 00-19

This page was intentionally left blank

## OPERATOR INSTRUCTIONS

### FPU SYSTEMS OPERATION MANUAL (INCLUDING REPAIR PARTS & SPECIAL TOOL LIST) STANDARD AND SPECIALIZED FPU MODULES BOH FPU Field Pack-up Units

#### OPERATION OF FPU SHORT/HELO MODULE

#### SHORT/HELO MODULE



Obsolete Style Cage

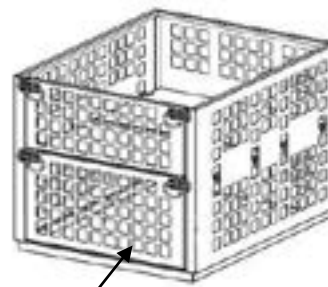

New Style Lite-Cage

The Short/HELO module consists of 1-4", 3-6" and 1-8" deep drawer for the shipment/storage of small and medium size material. Drawer compartments are adjustable in 2-inch increments from front to back and vary from side to side depending on the size of the drawer. Four-inch drawers are equipped with bi-fold covers or a new solid slide type cover. The maximum drawer capacity is 200 lbs. The Short/HELO module is designed with a new style removable top cage. The older style cage is no longer provided; replace it with the new version P/N 16500340 when required. Both cages have a fold down bi-fold door and adjustable shelves. All modules are designed to be inserted into any of the FPU-8 and FPU-20 series containers.

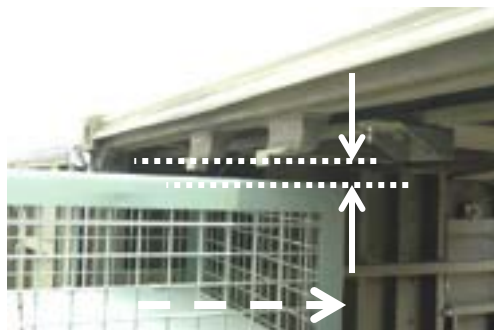

#### WARNING



Keep clear and do not attempt to push material down while the module is being loaded.

0006 00-1

### Module Data Tag Location

The Short HELO module data tag (1) is located at the rear bottom right corner of the module (2).

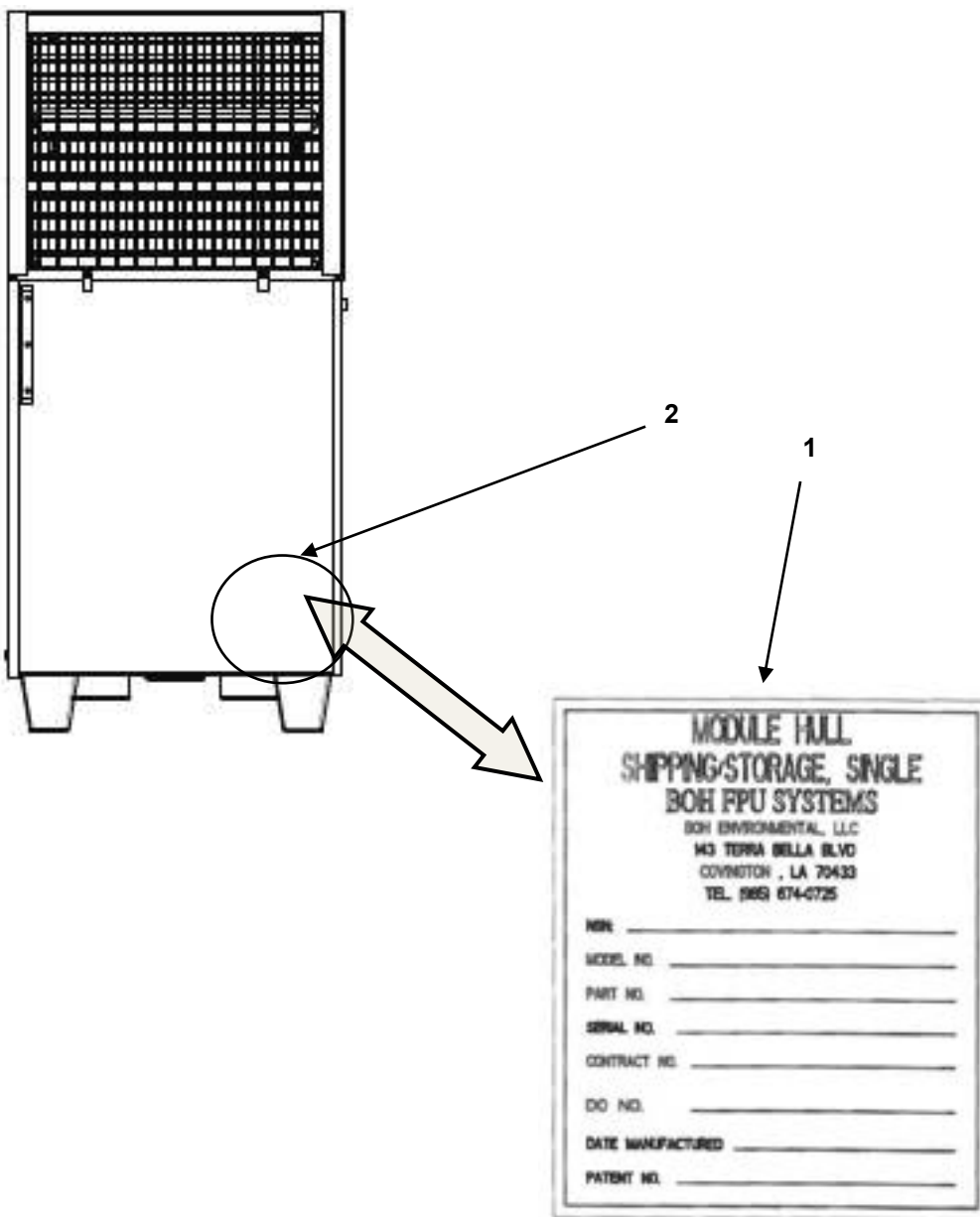



## MODULE DRAWERS

There are various prescribed divider sets provided with each size standard module drawer. The drawer divided segments can be customized with additional optional sets of dividers.

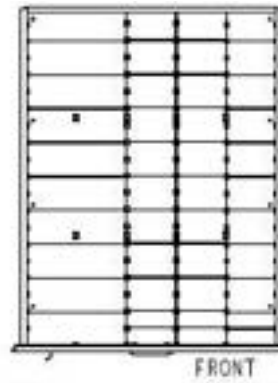

ALT. DRAWER  
CONFIGURATION

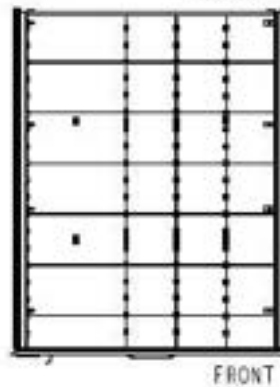
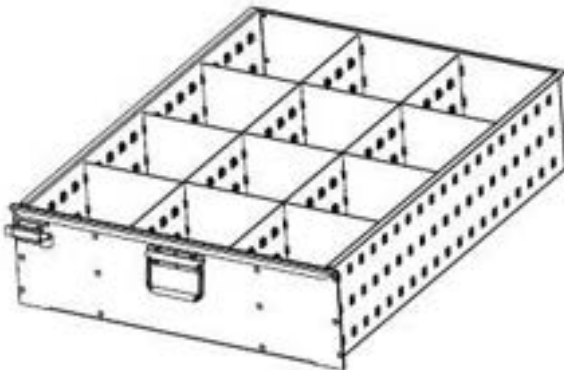

STANDARD DRAWER  
CONFIGURATION

The drawer segments can be easily enlarged or reduced by simply adding or removing dividers.

## THE FOUR INCH DRAWER COVERS

There are two versions of the 4" drawer lid to provide debris control and containment of very small parts during shipment. The sliding lid version (1) slides over the drawer from the front and covers all the dividers. An older folding lid version (2) is double hinged and has a support rod (3) located underneath each side. When the lid is raised, the rod supports the lid for easy access to the material.

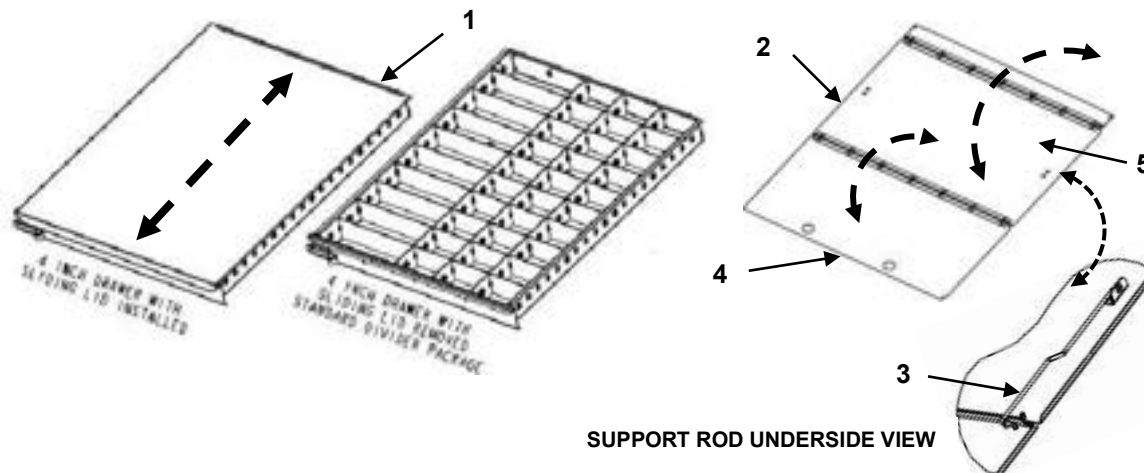

SUPPORT ROD UNDERSIDE VIEW

### Note

The folding 4" drawer lid is an older version and is available, CAGE 1NSG3 P/N16020424

### Opening Folding Lid Cover

1. Grasp the front portion of the lid (4) by the two front finger holes and lay it back onto the rear lid portion (5).
2. Grasp the front edge of the rear lid portion (5) and raise it until the support rods (3) are engaged and the lid (2) is supported in the fully open position.



There is a 4" bulk drawer version with a net (6) secured through the use of footman loops (7) around the edge of the drawer.

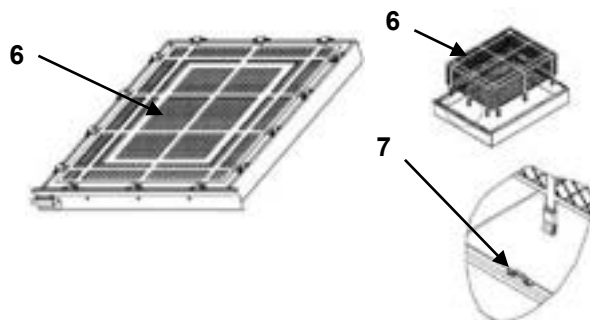

0006 00-4

## DRAWER REPLACEMENT

Although the Short/HELO modules come in prescribed drawer configurations, there are optional drawers of various sizes that can replace the existing configuration.

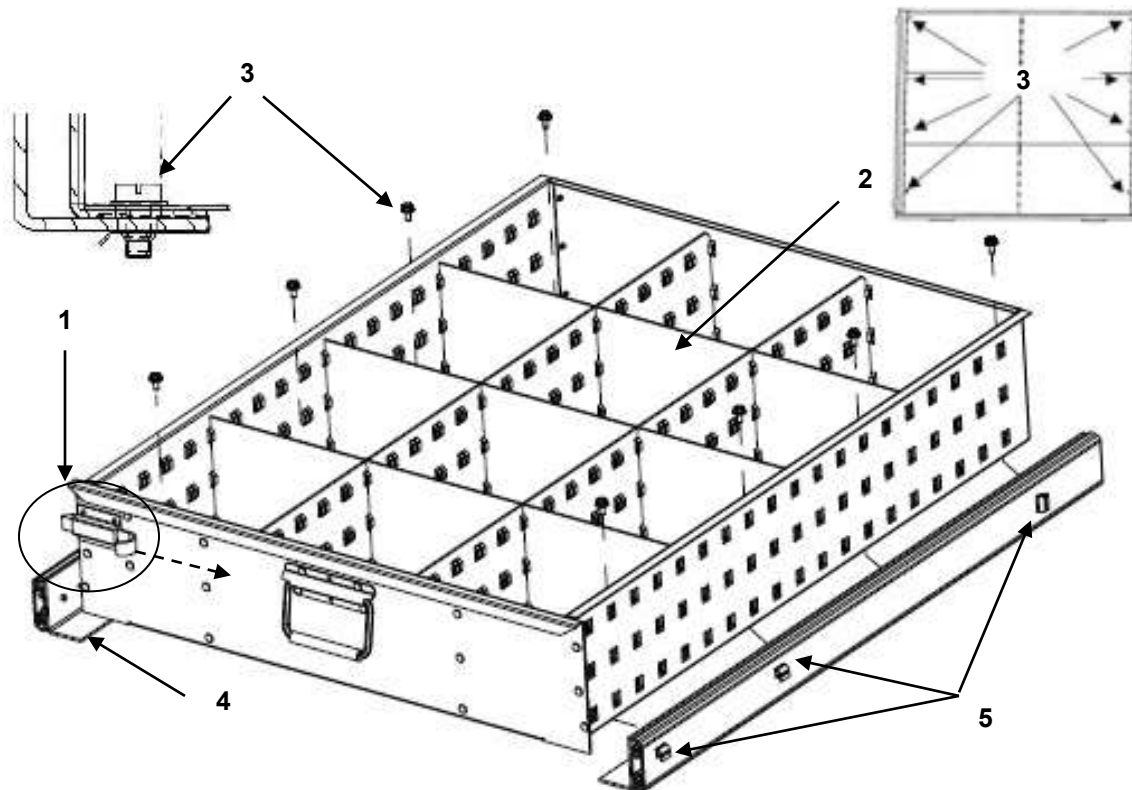

### Drawer Removal

1. Release the slam latch (1) on the left side of the drawer.
2. Pull the drawer to the fully out position.
3. Remove the material and divider set (2).
4. Remove the eight cap screws (3) on the interior of the drawer with the 7/16" socket wrench.
5. Lift the drawer from the bearing sliders (4).
6. Remove the two set screws that secure the slide to the module housing.
7. Use a block of wood and hammer to tap the sliders (4) up to disengage the tabs (5) and cleats.

### Bearing Drawer Slides

The drawers are attached to the roller slides (4), by means of auto thread clips (6) and screws (3).

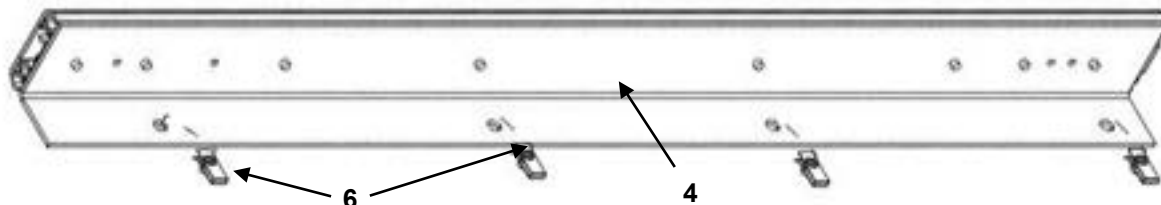

0006 00-5

There are two sizes of drawer slides, a single roller and double rollers (1) for the large drawers.

### Note

The drawer slides (1) come in left and right pairs as part of a drawer replacement kit and are matched to the drawer size.

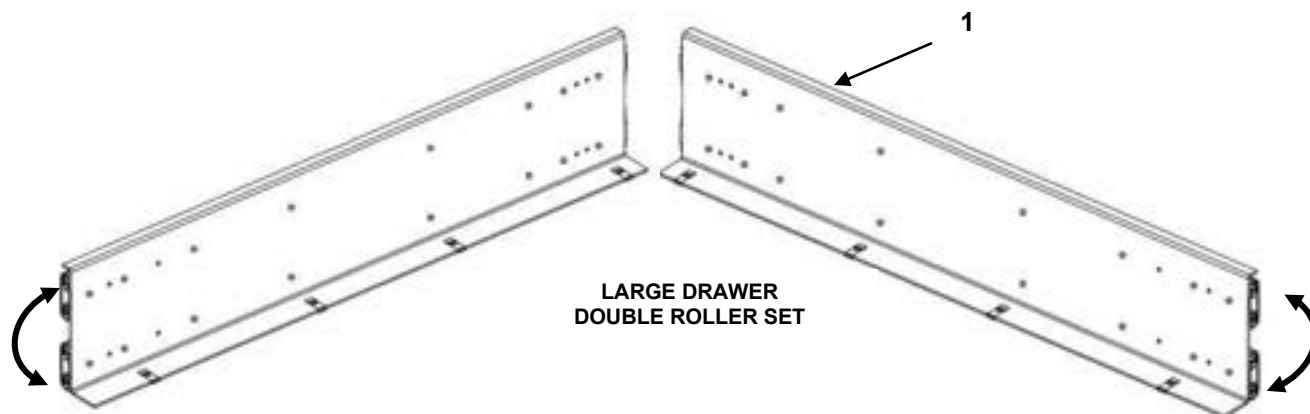

### To attach the drawer slide

1. Align the three sets of tabs on the back of the slide and tab holes in the three uprights.
2. Tap the slide down with a block of wood until the slide is level and secure with tabs.
3. Install the two set screws that secure the slide (1) to the module housing.
4. Insert the drawer and tighten the eight cap screws with the 7/16" wrench.
5. Push the drawer to the full in position till the slam latch is engaged.

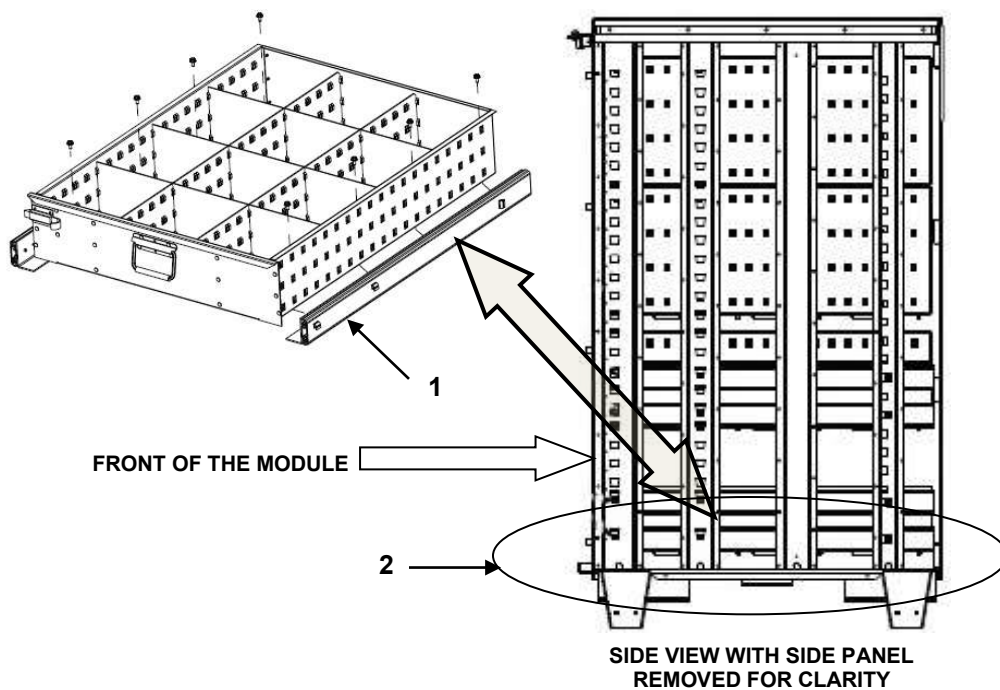

## PADLOCK SECURITY BAR

All Standard Modules drawers are retained by means of a pad lockable security bar.



All Standard and Specialized Modules may be secured within any FPU-8 or FPU-20 series containers by means of a removable cradle (1) and module locking arms (2).

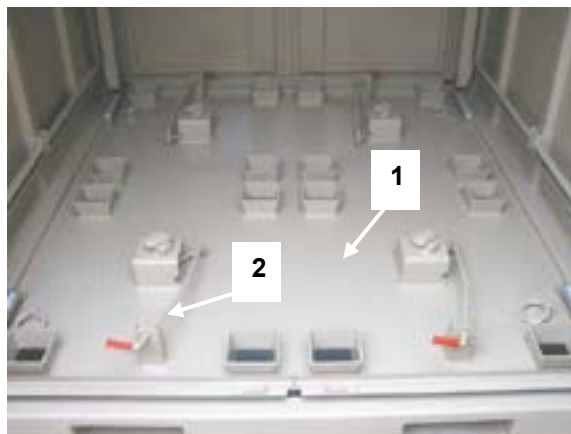
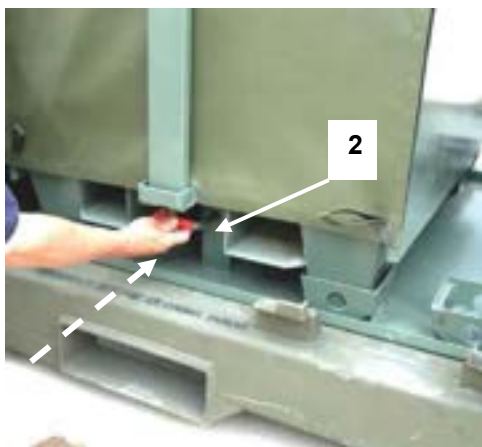

### CAUTION

Verify that the module is properly seated and the red handle on the module-locking arm (2) is pushed completely to its closed and locked position.

## VINYL WEATHER PROTECTION COVER

Each module is provided with a black vinyl weather protection fitted cover (1), for basic weather protection, attached by Velcro strips and removed by using nylon straps (2).

1. Place the cover (1) over the module front, attach with the hook and pile Velcro.

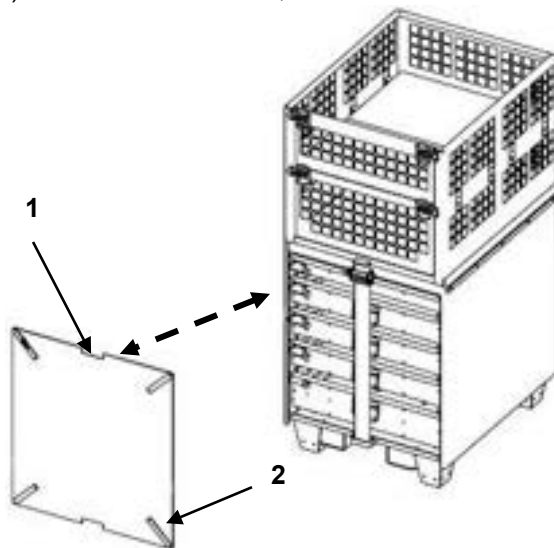

**END OF WORK PACKAGE**

---

**OPERATOR INSTRUCTIONS****FPU SYSTEMS OPERATION MANUAL  
(INCLUDING REPAIR PARTS & SPECIAL TOOL LIST)  
STANDARD AND SPECIALIZED FPU MODULES  
BOH FPU Field Pack-up Units****OPERATION OF FPU WEAPONS VAULT MODULE**

---

**WEAPONS VAULT MODULE for M16A2/M4 RIFLE, 9MM PISTOL**

The Weapons Vault Module is constructed with a dual wall that has an all-steel exterior/interior and accommodates any combination of 5 weapons drawers. This module is secured using a three point lock blade and bars system in the door assembly and key lock located behind the locking bar that accommodates high security padlocks to include the MIL-4307G 833-001/833-005 padlocks with cut guards. The Weapons Vault Module is interoperable between the FPU-8 and FPU-20 series containers.



### Module Data Tag Location

The Weapons Vault Module data tag (1) is located at the rear bottom right corner of the module (2).

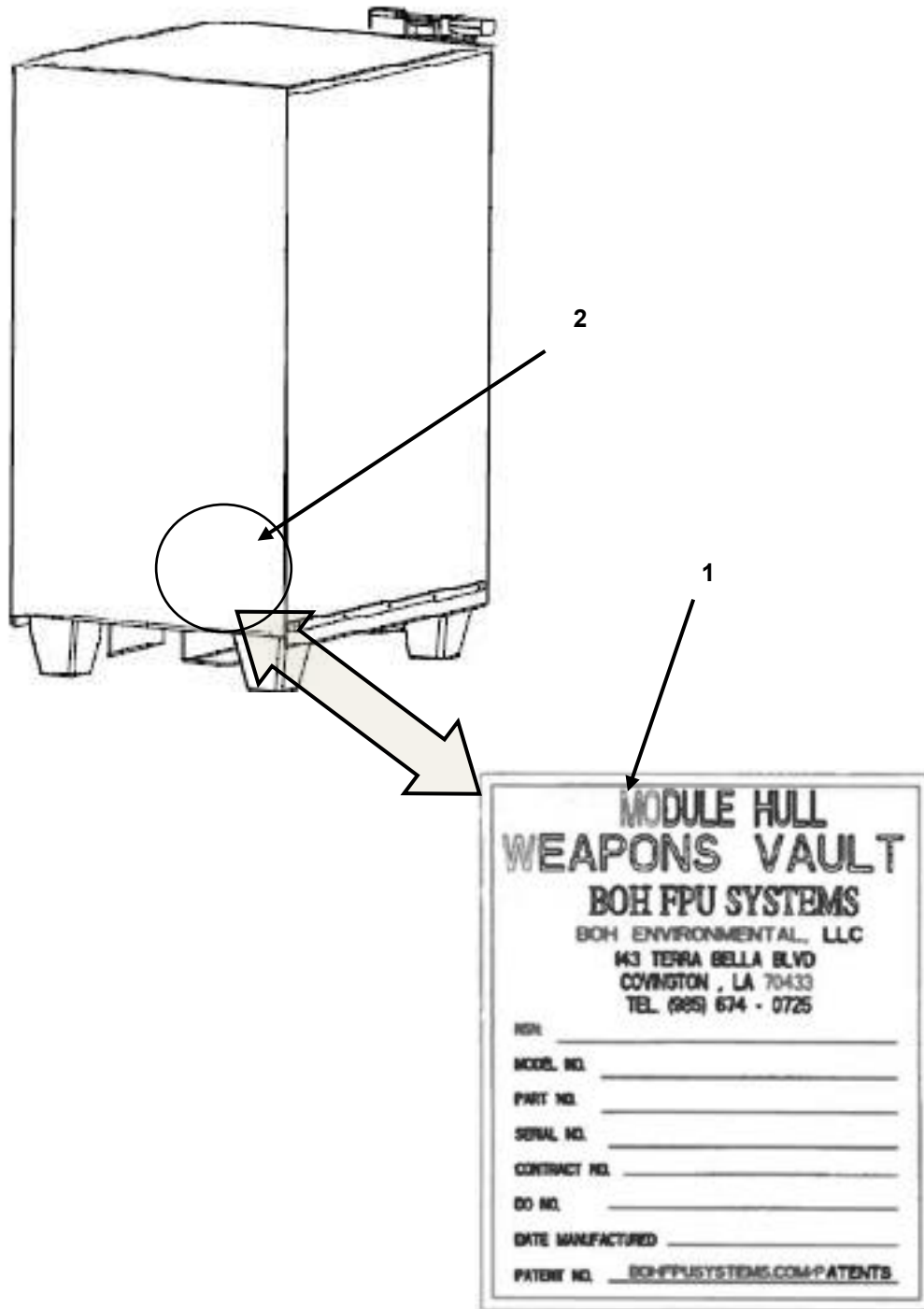



## SECURITY BAR KEY LOCK AND PAD LOCK

The security bar (5) is designed to cover the door key lock set (6) and handle (7), and is provided with an integrated padlock device (4) for vault security.

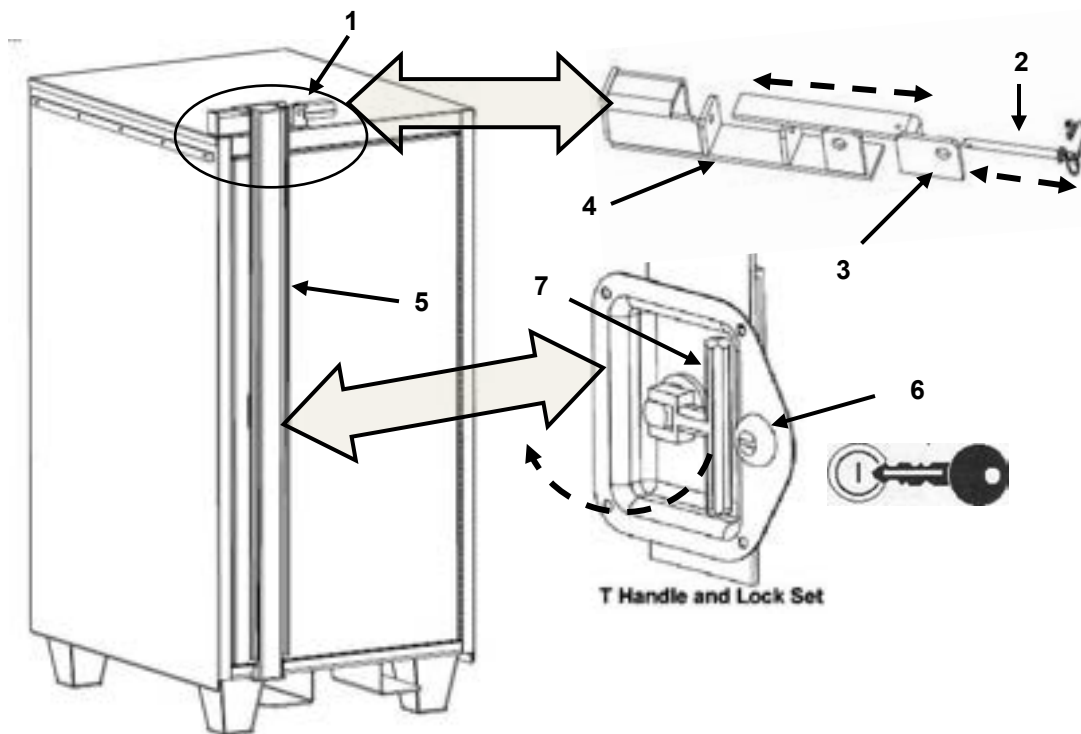

### CAUTION

Maintain security control of the vault keys

### Old Procedure

1. Remove the security padlock (1).
2. Remove the securing pin (2).
3. Remove the Sergeant Greenleaf padlock bar (3) from its base (4).
4. Remove the front security bar (5).
5. Unlock the key lock set (6), with the provided keys.
6. Swing out the T handle (7), rotate the handle clockwise and pull open the door.

### Note

The securing pin (2) has been removed from all weapons modules beginning with serial number AC15500003-047444. The accompanying holes in the padlock bar (3) and base (4) have been removed as well.

### New Procedure

1. Remove the security padlock (1) and/or round snap pin (8).
2. Same as steps 3 through 6 above.

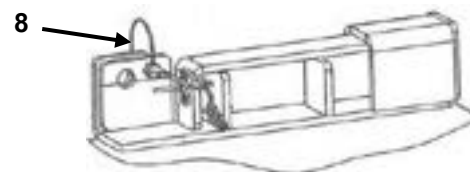

### NEW DESIGN

### CAUTION

Round snap pin (8) must be inserted when padlock (1) is unavailable.

0007 00-3

## WEAPONS VAULT DRAWERS

The Weapons Vault Drawers (2, 3, 4 and 5) are mounted on five left and right roller bearing drawer slides (1) for ease of access. The weapons module is designed to arrange drawers in any combination of M16A2 rifle drawer (2), 9 mm pistol drawer (3), M16/M4 adjustable rifle drawer (4), and 8-inch deep accessory drawer (5) variations.

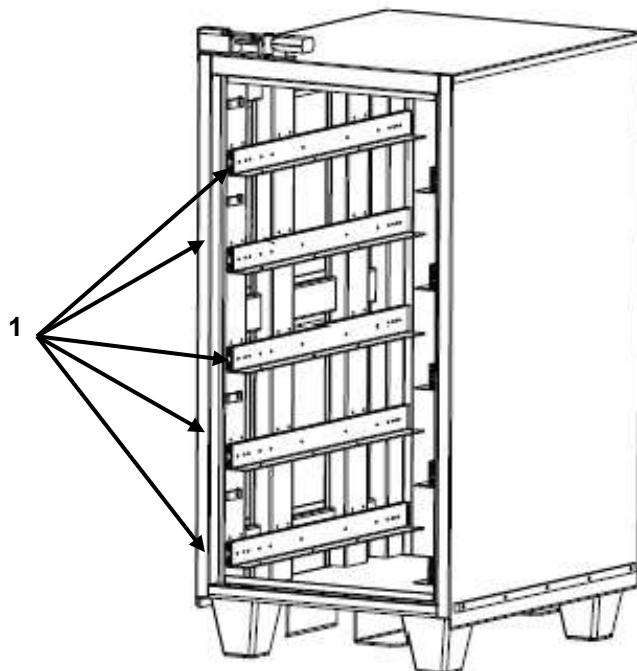

### NOTE

Vault Door and drawers removed for clarity

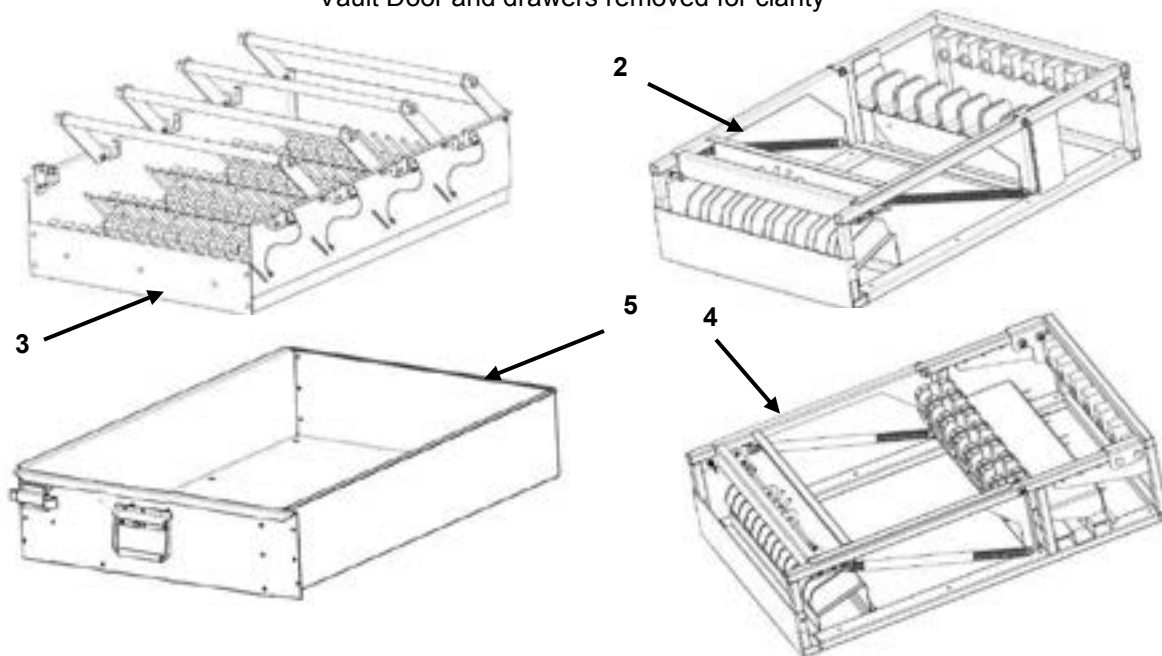

0007 00-4

## M16A2/M4 Rifle Drawer

The M16/M4 rifle drawers (1) are designed to secure seven M16A2, M16A4 or M4 rifles with adjustments for M16A2/A4, M4 14" and M4 10" barrels of various models with stock and barrel padded cradles and a spring operated swing down security bar. The M16A2 drawer is designed for this rifle specifically and secures eight rifles. Rifles are stored horizontally to maximize space and improve the weapon issue/ turn in and inventory processes. The frame rack may be removed from the drawer slides for transport and can stand alone as an upright gun rack.



M16A2 and M16/M4 rifle drawers are retained in the module (vault) by means of a spring-loaded pin and latch on the left side that engages when pulled and rotated ½ turn, and released when the drawer is in the fully closed position.

### CAUTION

Ensure the plunger pin (3) is retracted when closing the drawer, to prevent damage to the pin and frame.

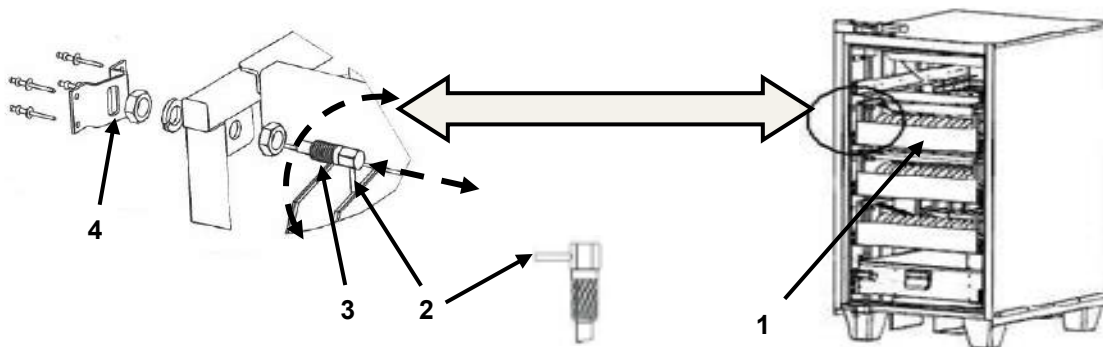

### Opening and Closing the Drawer

1. When opening the drawer, grasp the front face of the drawer (1) with one hand to maintain control. Then, with the other hand, grasp the plunger pin bar (2), pull outward and rotate ½ turn until the pin stays in the extended position and the drawer rolls free.
2. When closing the drawer (1), grasp the front face of the drawer with one hand to maintain control.
3. Then with the other hand, grasp the plunger pin bar (2), pull outward and rotate ½ turn until the pin stays in the retracted position.
4. Move the drawer (1) into the fully closed position.
5. Rotate the plunger pin bar (2) until it releases and engages the slot (4) within the module frame, and the drawer is latched.

### WARNING



Always ensure the plunger pins (3) are engaged and the drawers (1) do not roll free. Failure to do so will result in injury or damage to equipment.

## INSTALLING M16A2 and M16/M4 IN THE RIFLE DRAWER

### Note

The M16A2 drawer secures eight rifles in the same fashion as illustrated below, but is not adjustable to other rifle models.

The M16A2/M4 rifle drawer (1), is designed to secure seven rifles by means of lockdown bar (2) and adjustable padded cradles (4) for the barrel, forearm and stock to accommodate either the M16A2, M4 14" or 10" barrel type rifles.

### Note

Due to the large variety of M4 forearm grip sizes, the padded cradles must be trimmed to fit.

### WARNING

Consult the DOD M16A2 or M4 field hand book for weapon safety before placing weapons in the vault.

1. Insure the weapons have been unloaded and the magazines have been removed.
2. To install the weapon in the drawer (1), grasp the ring and pin (3), pull out and rotate ½ turn until engaged and the pin remains out.
3. Pull the drawer to the full out position.
4. Release the lockdown bar (2) by squeezing both release latch levers (5) together.
5. Control the spring-loaded bar (2) with both hands and allow the spring to raise the bar to the fully raised position.
6. Place the unloaded weapons in the padded cradles (4) with the magazines removed.

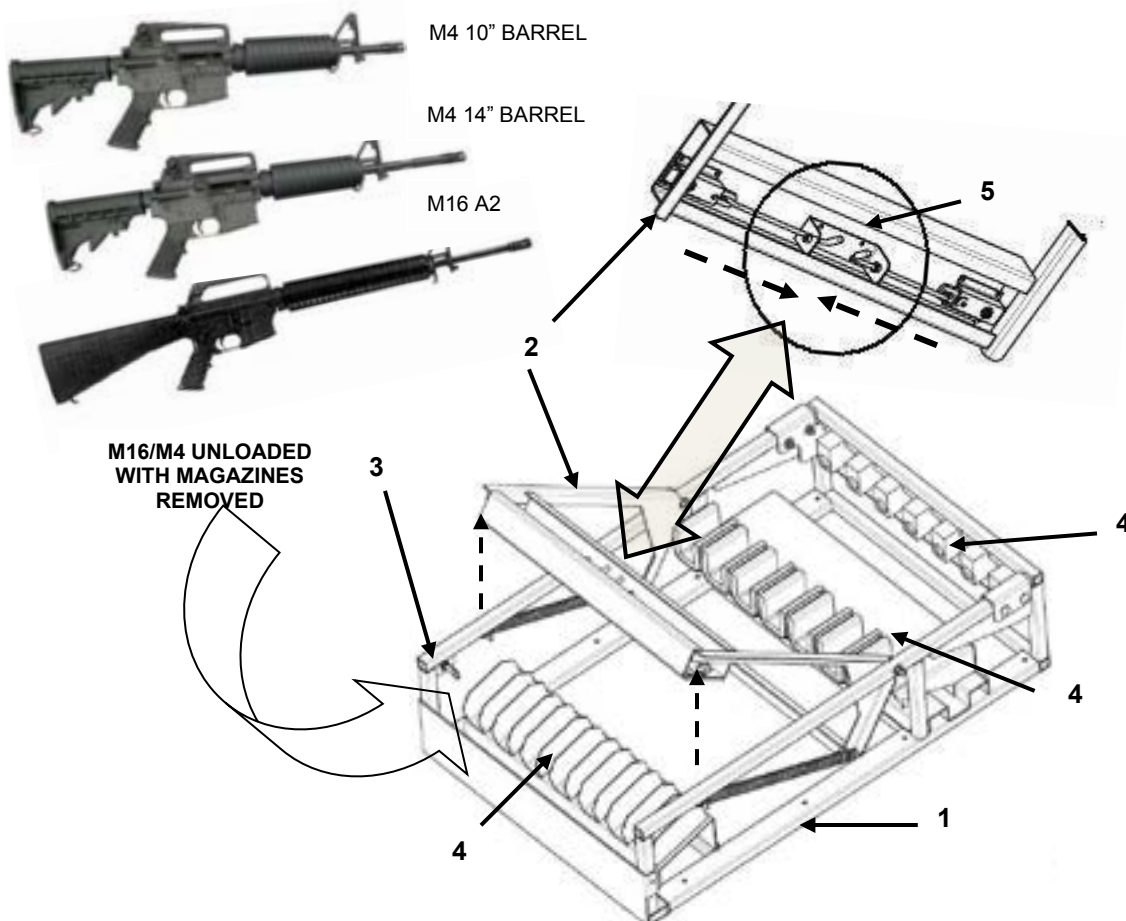

0007 00-6

7. With both hands, grasp the center top front edge and push the spring loaded securing bar (1) downward until the spring loaded bar latches (2) are engaged.

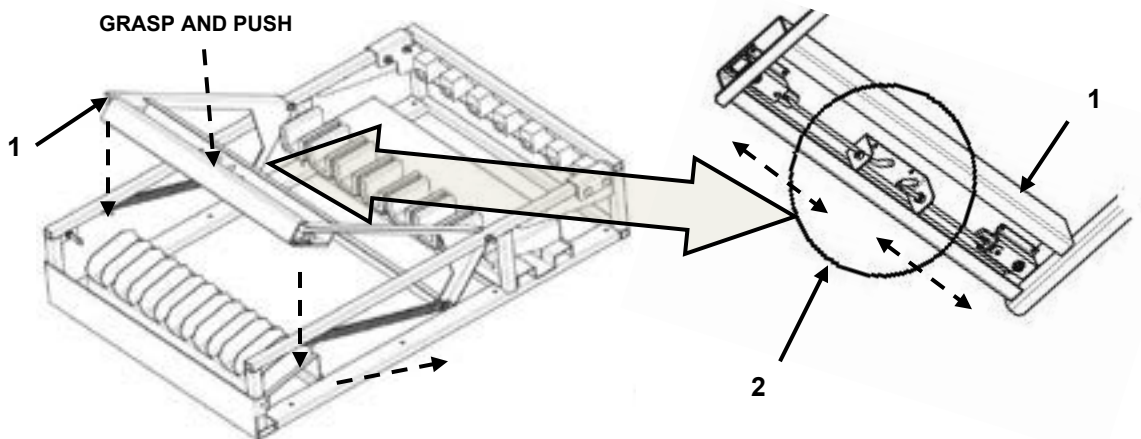

**WARNING**



Keep fingers and hands on the top center of the bar when closing the bar. Ensure the bar (1) is firmly latched; failure to do so may cause injury. Always ensure the plunger pins (3) are engaged and the drawers do not roll free. Failure to do so will result in injury or damaged equipment.

**Closing the Drawer**

**CAUTION**

Ensure the plunger pin bar (5) is fully retracted when closing the drawer, to prevent damage to the pin (3) and frame.

1. Grasp the plunger pin bar (5), pull out and rotate  $\frac{1}{2}$  turn until disengaged and the plunger pin (3) is retracted.
2. Return the drawer to the fully closed position, rotate and release the plunger pin bar (5) to seat the plunger pin (3) into the frame slot (4).

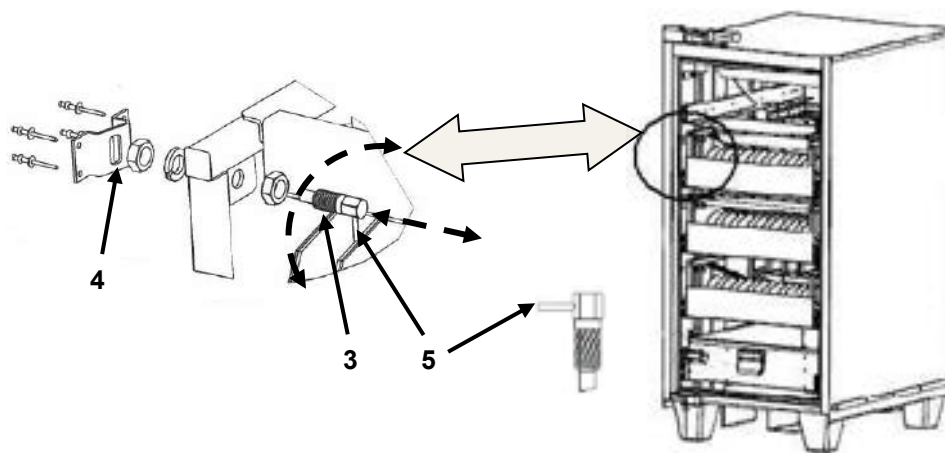

0007 00-7

## M16, M4 14" and M4 10" Gun Barrel Weapon Cradle Adjustments

1. Place the weapons drawer on a firm stable surface.
2. Release the Lock Arm (1) to the upright position.
3. Remove the three retaining bolts (2) for the center cradle blocks group (3) and lift and position it to one of the two desired positions.
4. Install and tighten the hardware (2).
5. Remove the four retaining bolts (4) and reposition the muzzle blocks group (5) to one of the three desired positions.
6. Install and tighten the retaining bolts (4).

### CAUTION

The Stock Butt Cradles Group (6) is not to be moved.

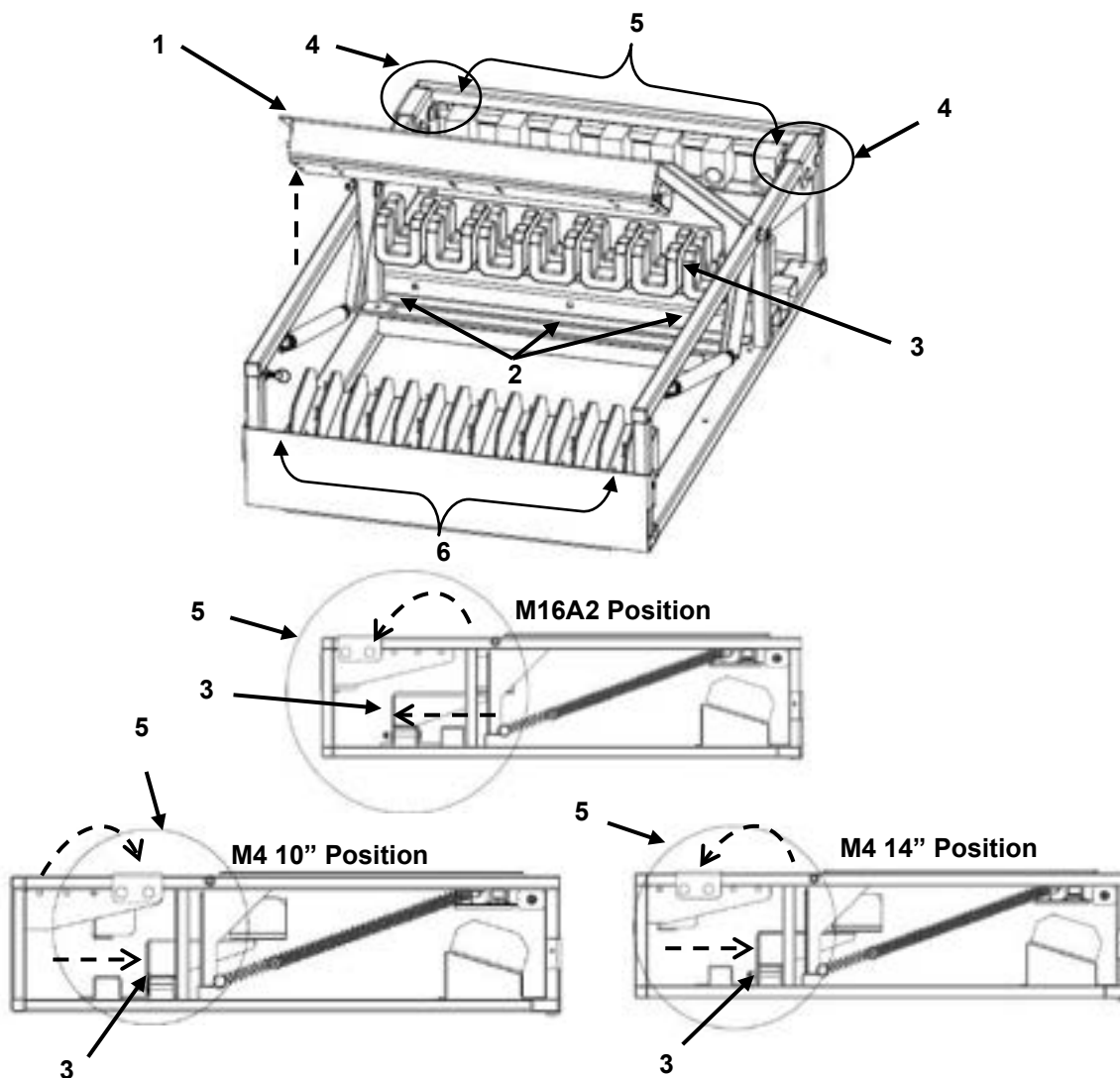

### Cradle Block Group and Muzzle Block Group Positions

The M16 A2 muzzle block group is located in bolt holes 1 and 2, with the Cradle block group in the front position.

The M4 with 14" barrel is located in bolt holes 2 and 3, with the Cradle block group in the rear position.

The M4 with 10" barrel is located in bolt holes 4 and 5, with the Cradle block group in the rear position.

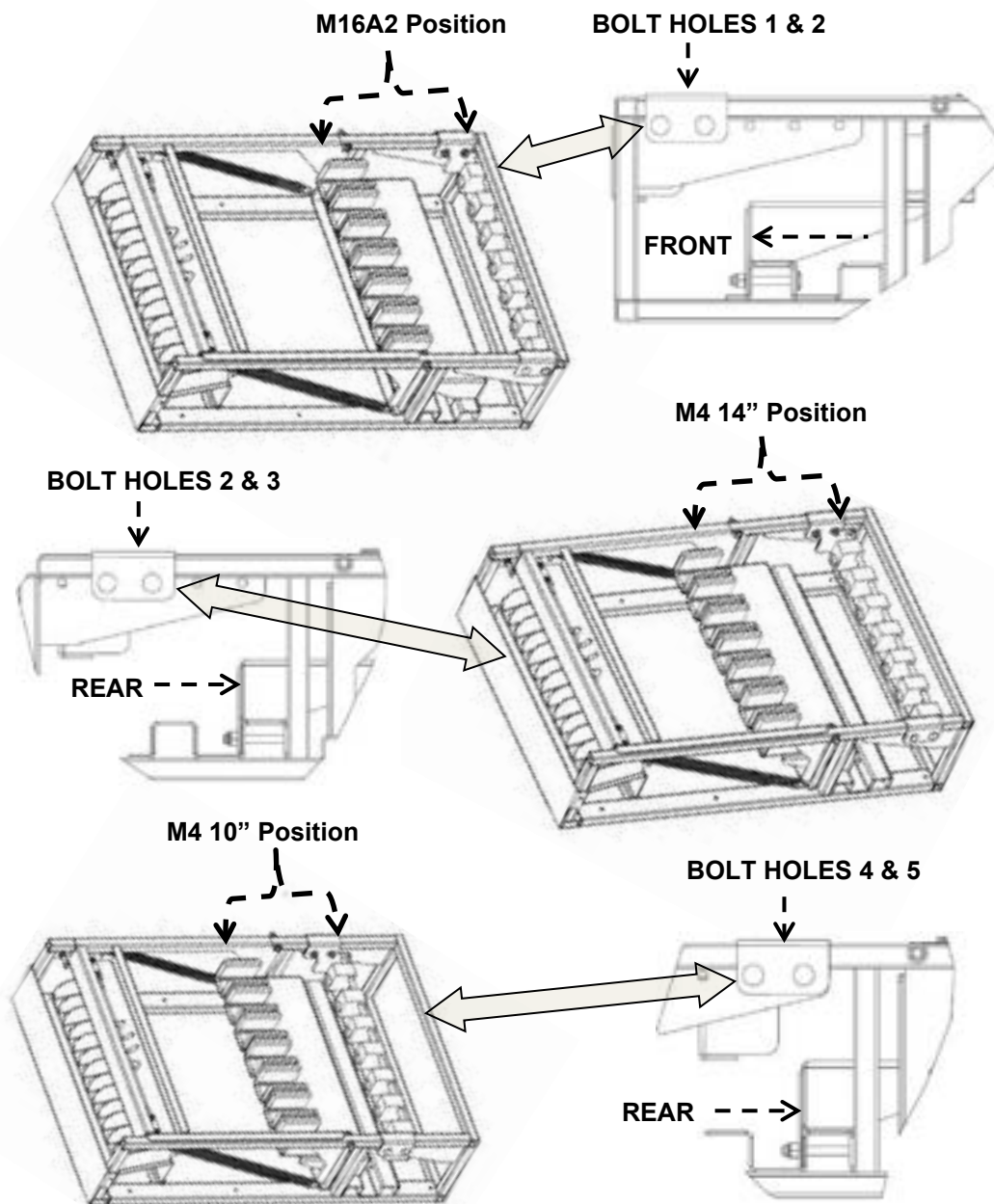

## 9mm PISTOL DRAWER

Each 9MM weapons drawer accommodates 56 pistols and is designed with 100% extension roller bearing slides for easy access. Pistols are stored horizontally to maximize space and improve the issue/ turn in and inventory processes. The pistol racks are bolted to the roller bearing drawer slides. Each 9mm pistol drawer is retained in the module by means of a spring-loaded pin latch located on the left side that engages when rotated ½ turn, and manually released once the drawer is closed. Drawers have a swing down locking device to secure items during storage and transport.

### CAUTION

Ensure the plunger pin (3) is retracted when closing the drawer (1), to prevent damage to the pin (3) and frame.

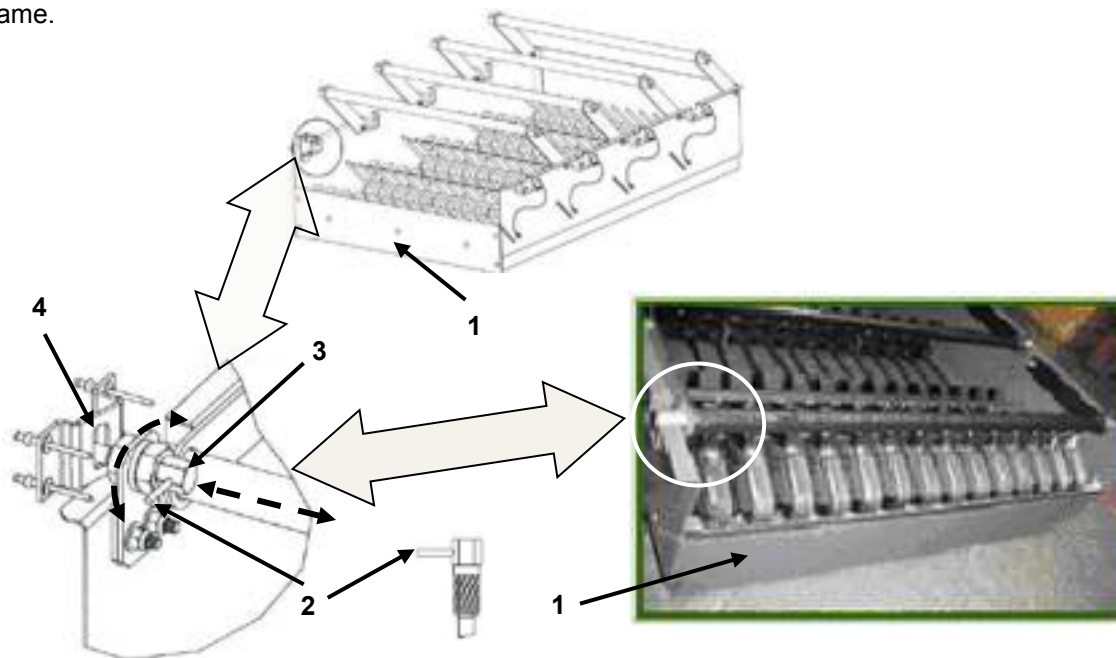

### Opening and Closing the 9mm Drawer

1. When opening the drawer, grasp the front face of the drawer (1) with one hand to maintain control. Then with the other hand, grasp the plunger pin bar (2), pull outward and rotate ½ turn until the spring pin stays in the extended position and the drawer rolls free.
2. When closing the drawer (1), grasp the front face of the drawer with one hand to maintain control, then with the other hand grasp the plunger pin bar (2), pull outward and rotate ½ turn until the spring pin (3) stays in the retracted position.
3. Move the drawer (1) into the fully closed position.
4. Rotate the plunger pin bar (2) until it releases and engages the slot (4) within the frame, and the drawer is latched.

### WARNING



Always ensure the plunger pins (3) are engaged and the drawers (1) do not roll free. Failure to do so will result in injury.

0007 00-10



## INSTALLING THE 9 mm PISTOLS IN DRAWER

### WARNING

Consult the DOD 9mm pistol field handbook for **weapon safety** before placing weapons in the vault. If the pistol muzzle does not **completely** seat on the nonmetallic barrel rod (3), there is a round in the chamber. **Cease immediately**, Remove the pistol, and clear the weapon. Loss of life or injury may result.

1. Insure the weapons are unloaded and the magazines have been removed.
2. Remove the security bar pins with lanyard (1) to raise each of the bars (2).
3. Place each pistol barrel onto one of the non-metallic barrel rods (3).

### NOTE

**SAFETY FEATURE** The non-metallic rods (3) have been designed to extend into the 9mm chamber to secure the weapon and prevent installing a loaded weapon (with Chambered Round) into the drawer. The pistol will not fit within the drawer frame in a loaded condition.

4. When the non-metallic barrel rod (3) is fully seated in the barrel, swing the pistol down to mate with the base pistol cradle (4) and magazine cavity.

### NOTE

**SAFETY FEATURE** The base pistol cradles (4) have been designed to extend into the 9mm magazine cavity to secure the weapon and prevent installing a loaded weapon (with magazine) into the drawer.

5. Lower each security bar (2) and insert the securing pins with lanyard (1) to secure the pistols.

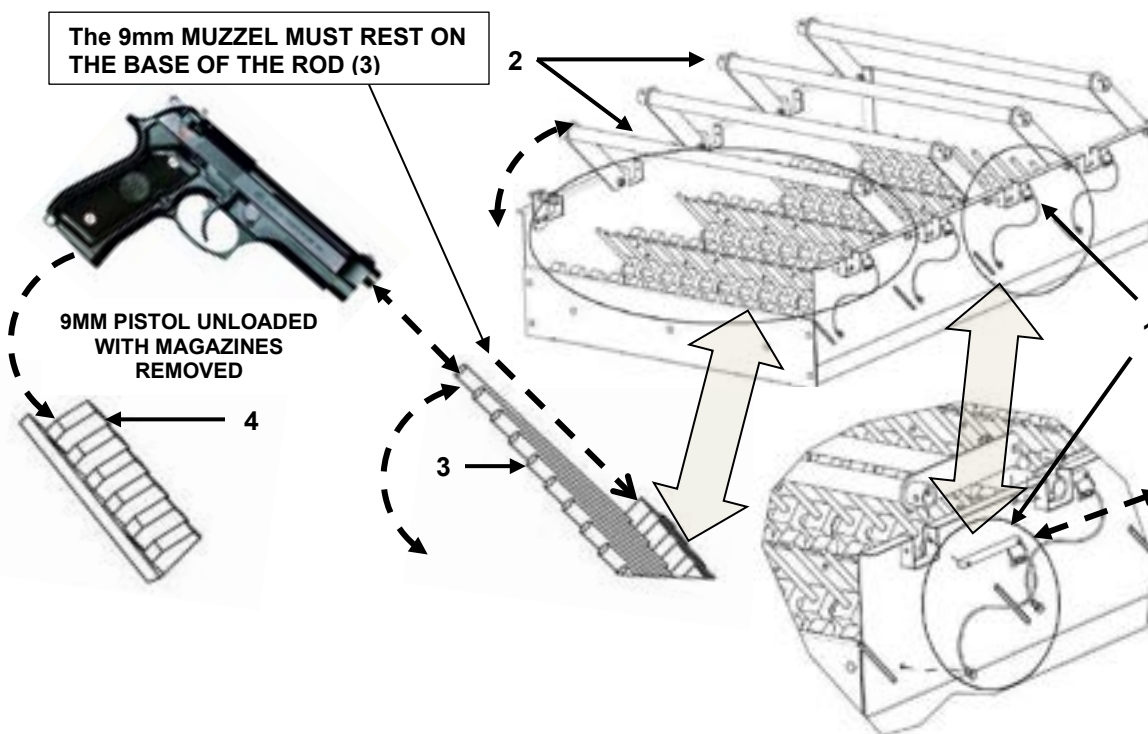

0007 00-11

### 8-inch Accessory Drawer

The 8 inch deep accessory drawers are mounted on roller bearing slides for ease of operation and access. The drawers are retained by a spring-loaded slam latch on the left side of the drawer.

#### NOTE

Vault Door removed for clarity

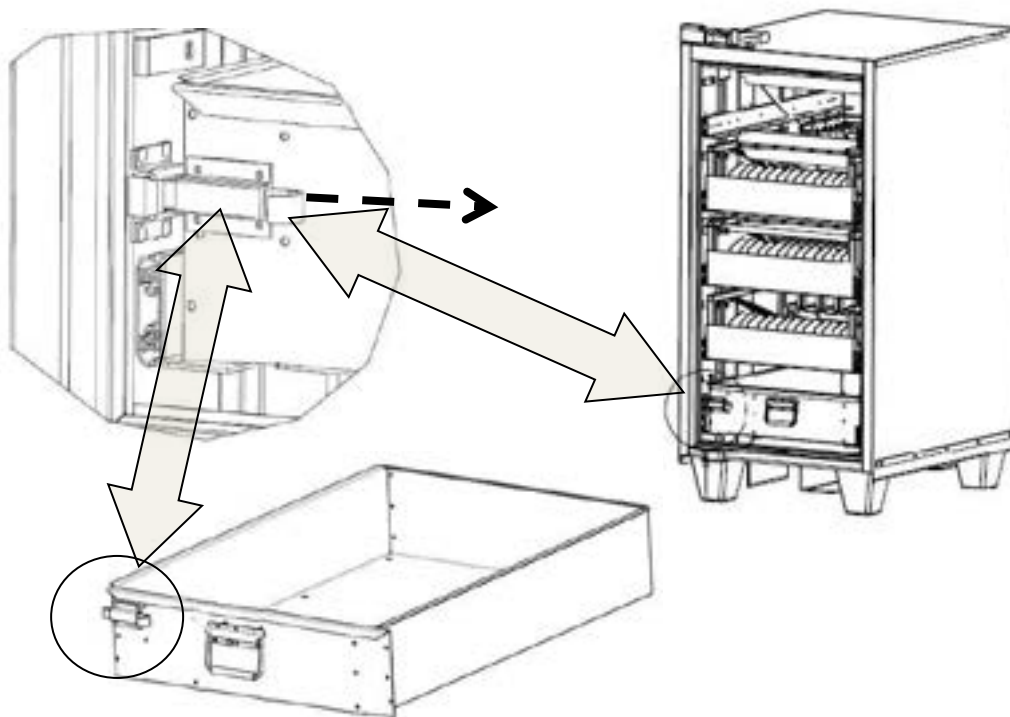

### Opening and closing the 8-Inch accessory drawer

1. Grasp the drawer handle with one hand to control the drawer.
2. Pull the spring-loaded slam latch to the right to release the drawer.
3. Pull the drawer to the full out position to gain access to the contents of the drawer.
4. Grasp the drawer handle and push the drawer until the slam latch is engaged in the fully closed position.

#### WARNING



Keep fingers and hands on the drawer handle when opening or closing the drawer.  
Ensure the drawer slam latch is firmly latched; failure to do so may cause injury.

**END OF WORK PACKAGE**

0007 00-12

---

**OPERATOR INSTRUCTIONS****FPU SYSTEMS OPERATION MANUAL  
(INCLUDING REPAIR PARTS & SPECIAL TOOL LIST)  
STANDARD AND SPECIALIZED FPU MODULES  
BOH FPU Field Pack-up Units****OPERATION OF FPU FLAMMABLE/CORROSIVE MODULE**

---

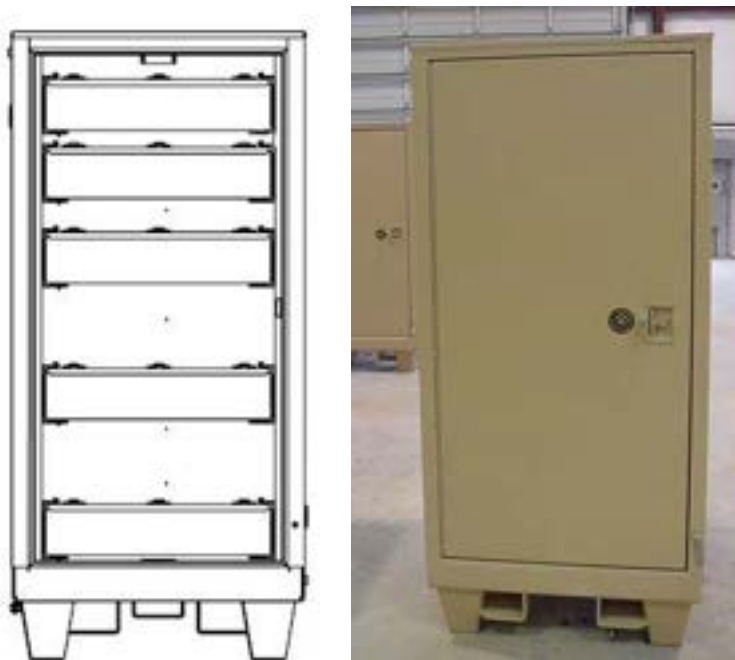
**FLAMMABLE/CORROSIVE MODULE**

**Door removed for clarity**

The Flammable/Corrosive Module is designed to be interchangeable; therefore, it may be inserted into any of our FPU-8 and FPU-20 series containers.

It is approved for air transport aboard USAF C-130, C-5, and C-17 aircraft with or without the FPU container and is constructed to meet NFPA 30 and 29 CFR requirements for flammable/corrosive material storage. Dual wall construction with all-steel exterior and spark resistant aluminum interior, continuous welded drawers and floor area provide containment in the event of leaks.

**FLAMMABLE/CORROSIVE MODULE SAFETY FEATURES**

- a. Two ground bolt connections with One ½" braided ground cable
- b. Nonmetallic no-spark rear and side rub strips
- c. Door pressure vent valve
- d. Top and bottom capped openings
- e. Nonmetallic no-spark drawer slides
- f. Material containment nets and continuous welded drawers
- g. Drawer retaining bar and door seal

### Module Data Tag Location

The Flammable/Corrosive Module data tag (1) is located at the rear bottom right corner of the module (2).

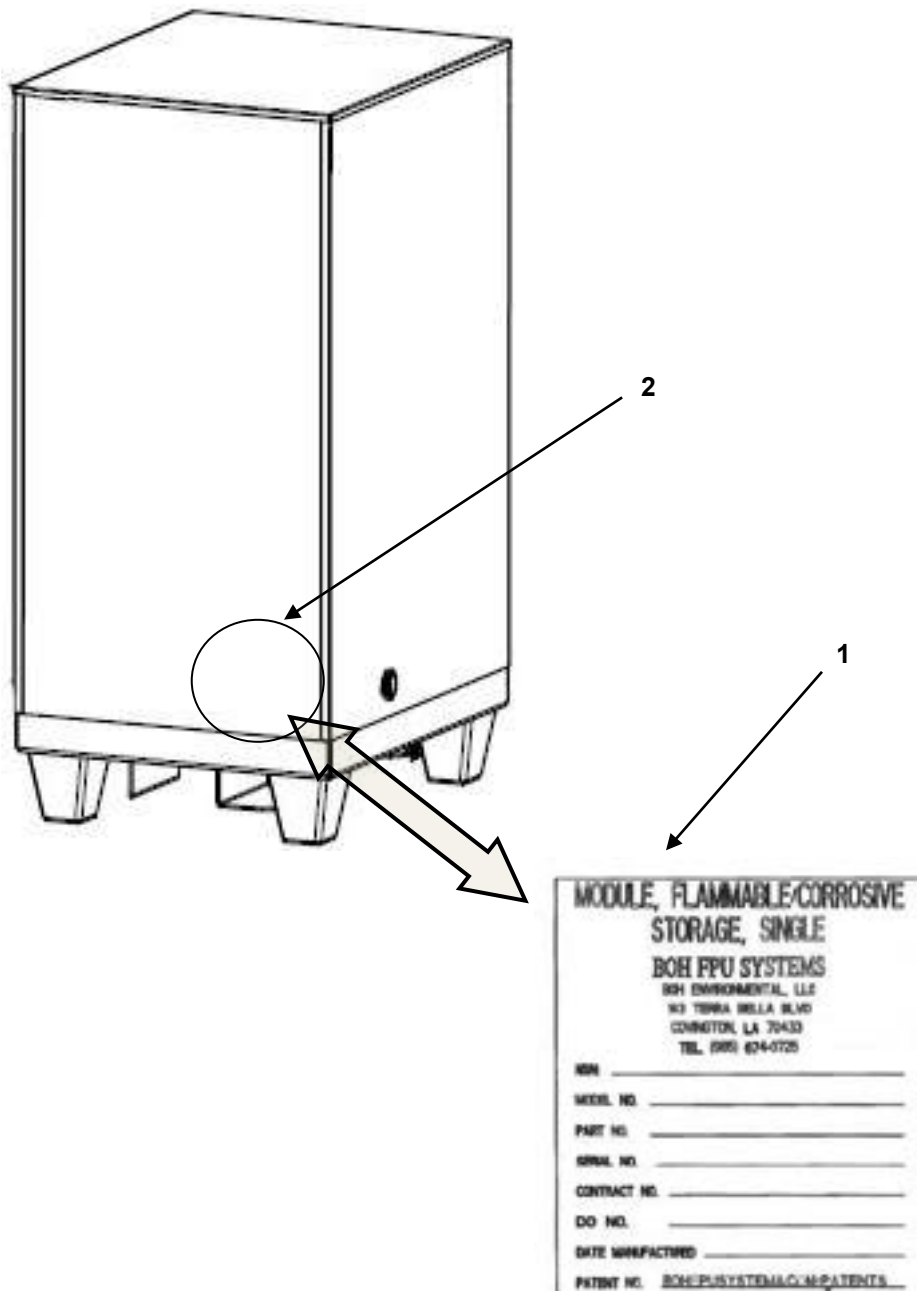

**WARNING**

The Flammable/Corrosive Locker module is designed to store and transport flammable and corrosive or explosive materials. Consult DOD 60055.9-STD Chapter 7 Grounding Procedures and DOD 4145.19-R-1 Storage and Handling Material Hazardous Commodities, prior to storage or transportation of materials. Flammable/Corrosive Locker module ground connection is required for safe operation.

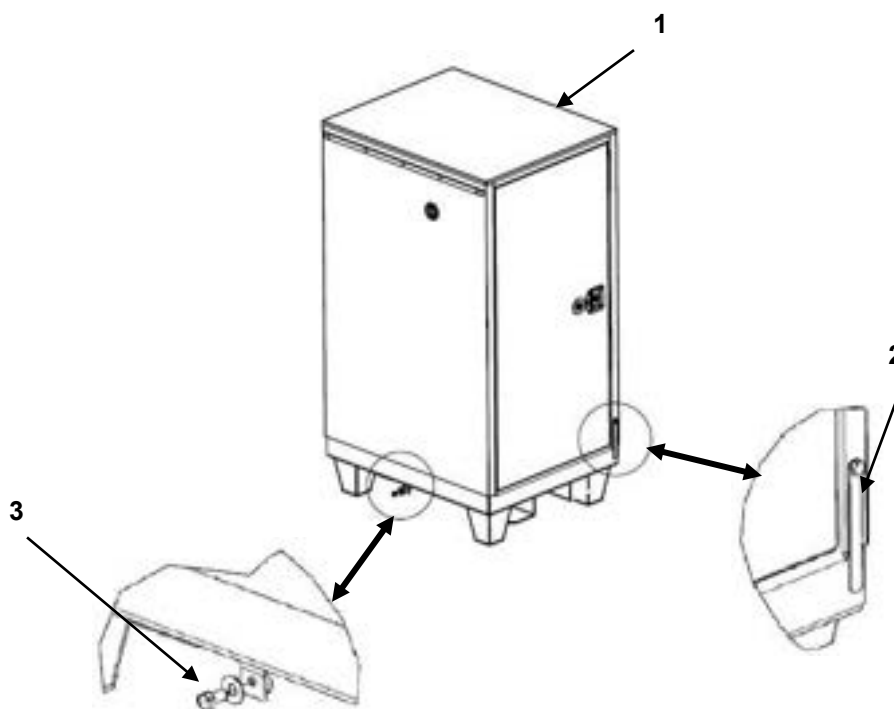
**Ground Connections**

The Flammable/Corrosive Module (1) is provided with a ½" flat braided copper ground strap (2) bolted to the frame located on the front of the module. There is a ground connection bolt washer and nut (3) located on the left side at the bottom of the module.

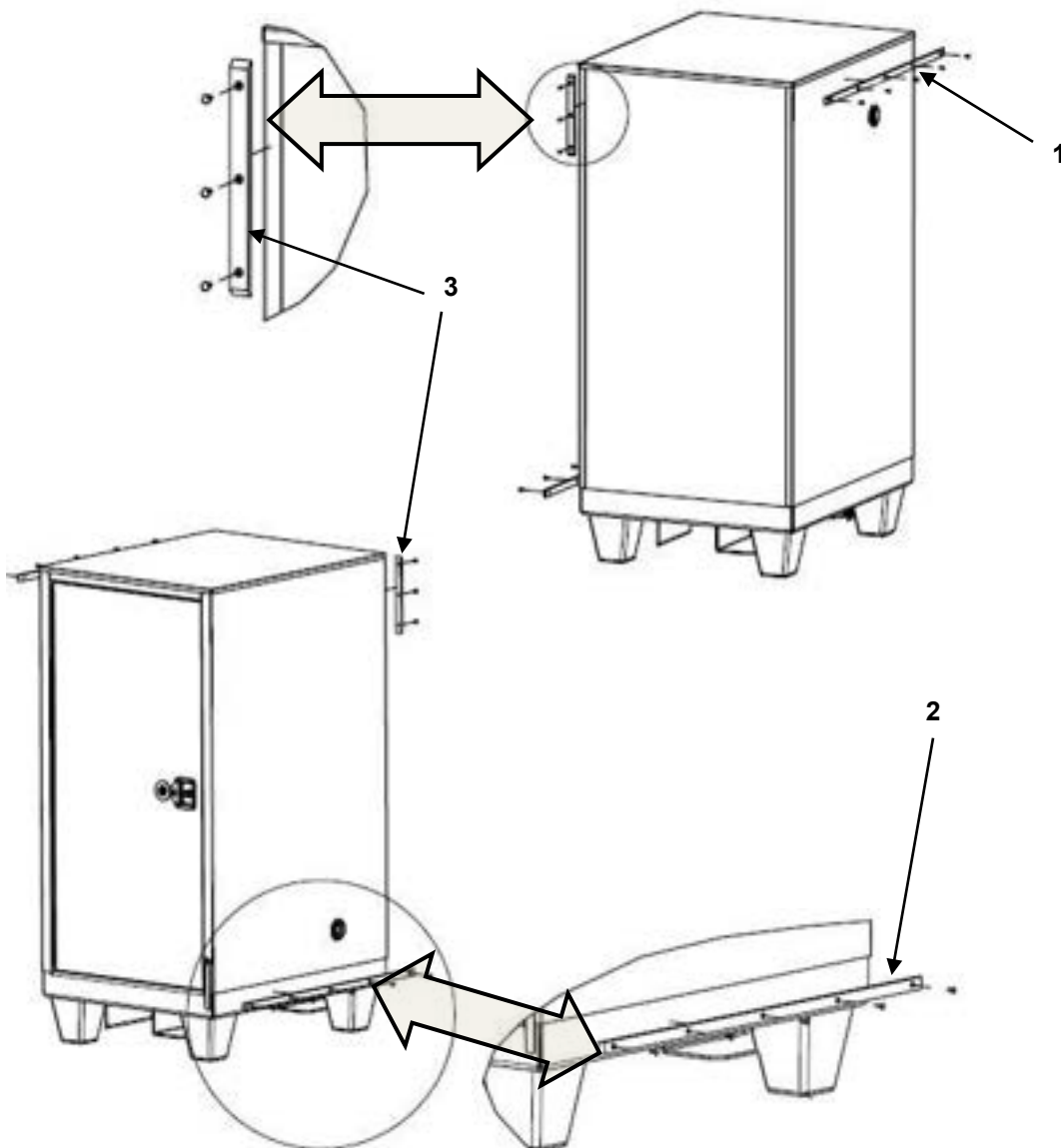
**FLAMMABLE/CORROSIVE MODULE SAFETY FEATURE****Non-Metallic Rub Strips**

Non-metallic rub strips are provided on the top left edge (1), lower right edge (2) and the back (3) to prevent sparking from metal to metal when loading or unloading the Flammable/Corrosive module.

## FLAMMABLE/CORROSIVE MODULE SAFETY FEATURE

### Door Pressure Vent Valve

Next to the door handle (1) there is a barometric pressure vent type valve (2) that permits the venting and equalization of internal air pressure when the Flammable/Corrosive Module has been stored in a hot, cold or aircraft pressure environment.

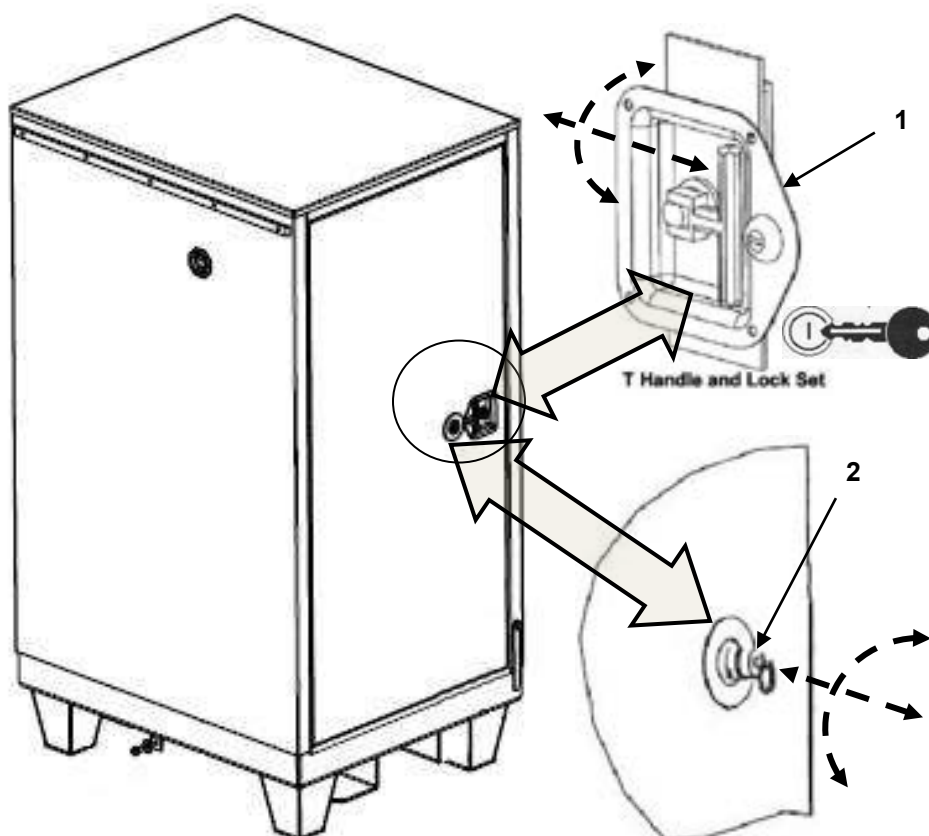

Prior to opening the door, equalize the internal pressure by pulling the valve ring and rotate it to hold the valve (2) in the open position.

## FLAMMABLE/CORROSIVE MODULE SAFETY FEATURE

### Top and Bottom Capped Volatile Gas Vents.

The capped gas vents (1) are used to evacuate potential volatile gasses to the outside of the module, for connection to a facility vent system.

#### WARNING



The Flammable/Corrosive Locker module is designed to store and transport flammable and corrosive materials. Consult DOD 60055.9-STD Chapter 7 Grounding Procedures and DOD 4145.19-R-1 Storage and Handling Material Hazardous Commodities, prior to storage or transportation of materials.

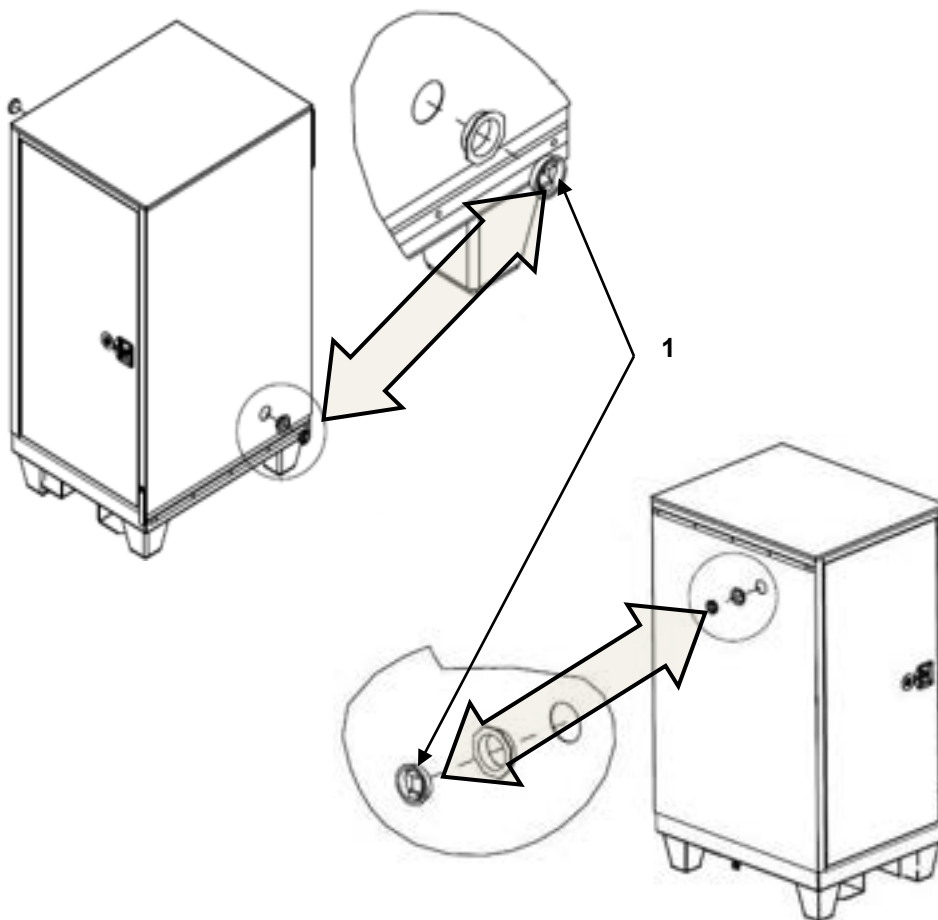

0008 00-6



## FLAMMABLE/CORROSIVE MODULE SAFETY FEATURE

### Non-Spark Drawer Slides

The drawer slides (1) mounted to the aluminum interior are provided with non-metallic strips (2) to insure spark prevention. The strips are used as a slide bearing surface for the drawers.

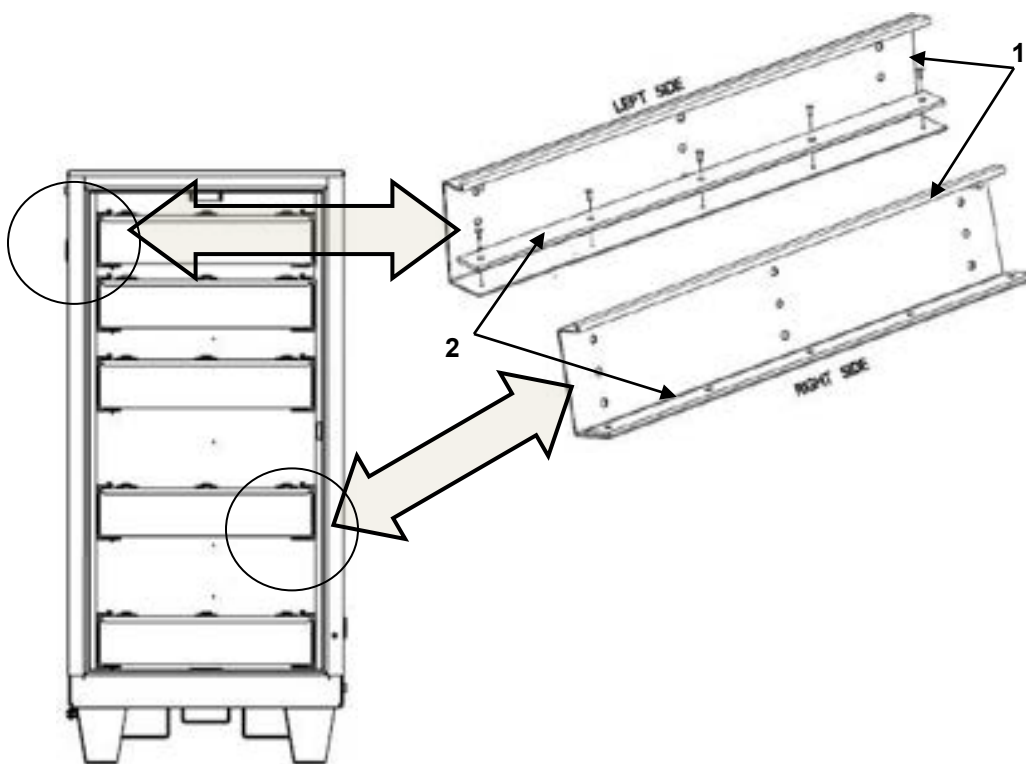

## FLAMMABLE/CORROSIVE MODULE SAFETY FEATURE

### Material Containment Nets and Continuous Welded Drawers

The five drawers (1) are continuous welded to contain spillage. The drawers are secured through a containment bar (2) with a securing pin (3). The Module is provided with two sizes of containment nets (4) (smaller nets for the top three drawers and large nets for the bottom two drawers) that have non-metallic strap clips (5) to secure material during transportation.

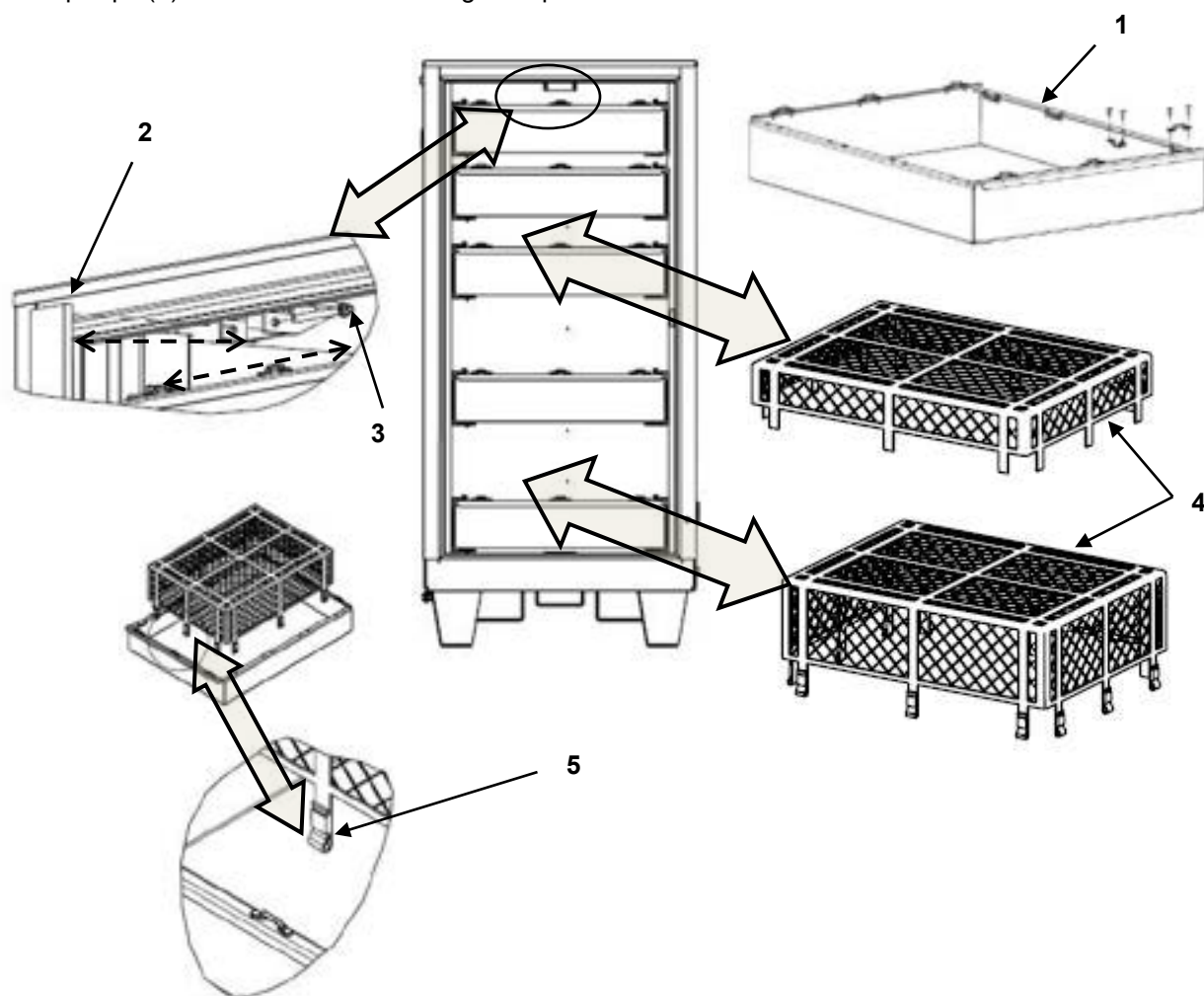

### Optional Module Casters

#### NOTE

These casters (1) are not designed or intended to be used on the FPU Bulk Modules.

A set of casters (1), is available for ease of movement and positioning in a warehouse setting. The casters fit the Standard and specialized modules, mentioned in this manual.

These casters (1) are designed for concrete and other firm surfaces, and are not intended for dirt, sand, mud or snow.

#### NOTE

The casters with foot brake pedals (3), should always be installed in the front of the module (2). This position provides access to the locking foot brake pedals (3) and access to the front of the module (2).

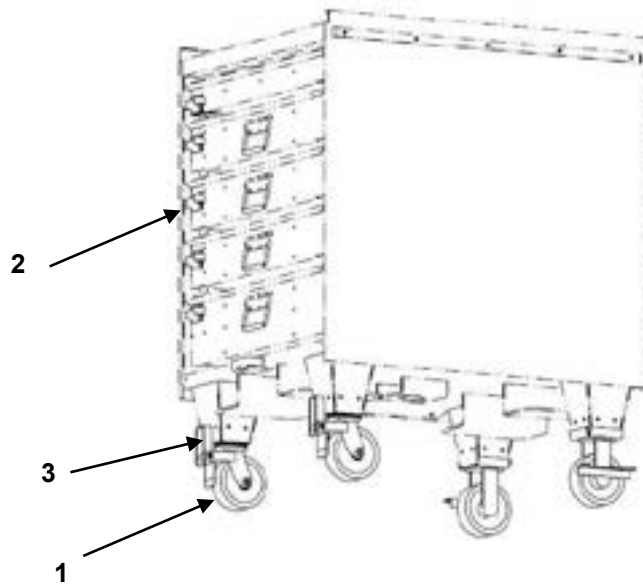

#### WARNING



Never install these casters (1) in the FPU Bulk Module; the casters (1) would collapse under the extreme weight of the FPU Bulk Module load. Never attempt to roll a module with casters (1) up/down a ramp or incline. Failure to comply may cause injury, death or damage to the equipment.



## Installing the Casters

1. MHE support is required to install the casters into the module feet (1).
2. Forklift tines, should maintain approximately 18-inches between the forklift-bridge and module (2), to prevent interference installing the casters.
3. A ground guide must be present during this operation and direct all movement of the MHE.
4. Elevate the desired module (2) approximately 3 feet to gain access to the holes in the module feet (1).
5. Position the front caster with the foot brake pedal (5) facing the front of the module (2).
6. From the right side of the module, insert the front caster (3), until the base (4) mates with the bottom of the foot (1).
7. Position the rear caster (7), with the open flange, facing the rear of the module (2).
8. Insert the rear caster (7) with the base opening (6) facing the rear until the base mates with the module foot (1).
9. Proceed to the left side of the module (2) and repeat steps 1 through 8.
10. With the casters in place, lower the module (2) to the ground.
11. Disengage the forklift.
12. Test the brakes by depressing both foot pedals (5) and attempting to move the module (2).
13. The module (2) should not move.
14. Release the brakes by raising the foot pedals (5) and move the module (2).
15. When the module (2) is in the storage position, set both brakes by depressing the foot pedals (5).

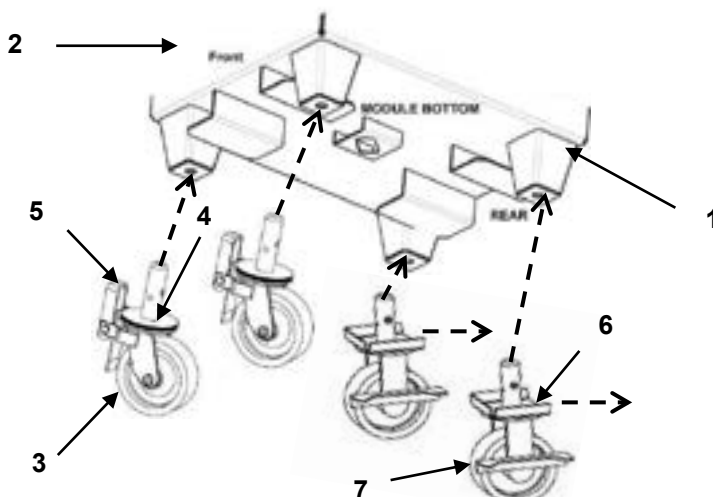

### WARNING



Standard MHE practices apply; a ground guide will direct all MHE movement. Always operate the modules with casters on a level firm surface. Never attempt to roll a module with casters up/down a ramp or incline. Failure to comply may cause injury, death or damage to the equipment. Failure to set the brakes on the casters may cause unwarranted movement and may cause injury, death or damage to the equipment.

### NOTE

The rigid casters (6) are no longer available as of February 2017. A module caster set will now include four swivel casters (3).

**END OF WORK PACKAGE**

0008 00-10

## OPERATOR INSTRUCTIONS

### FPU SYSTEMS OPERATION MANUAL (INCLUDING REPAIR PARTS & SPECIAL TOOL LIST) STANDARD AND SPECIALIZED FPU MODULES BOH FPU Field Pack-up Units

#### OPERATION OF FPU BULK STORAGE/SHIPPING MODULE

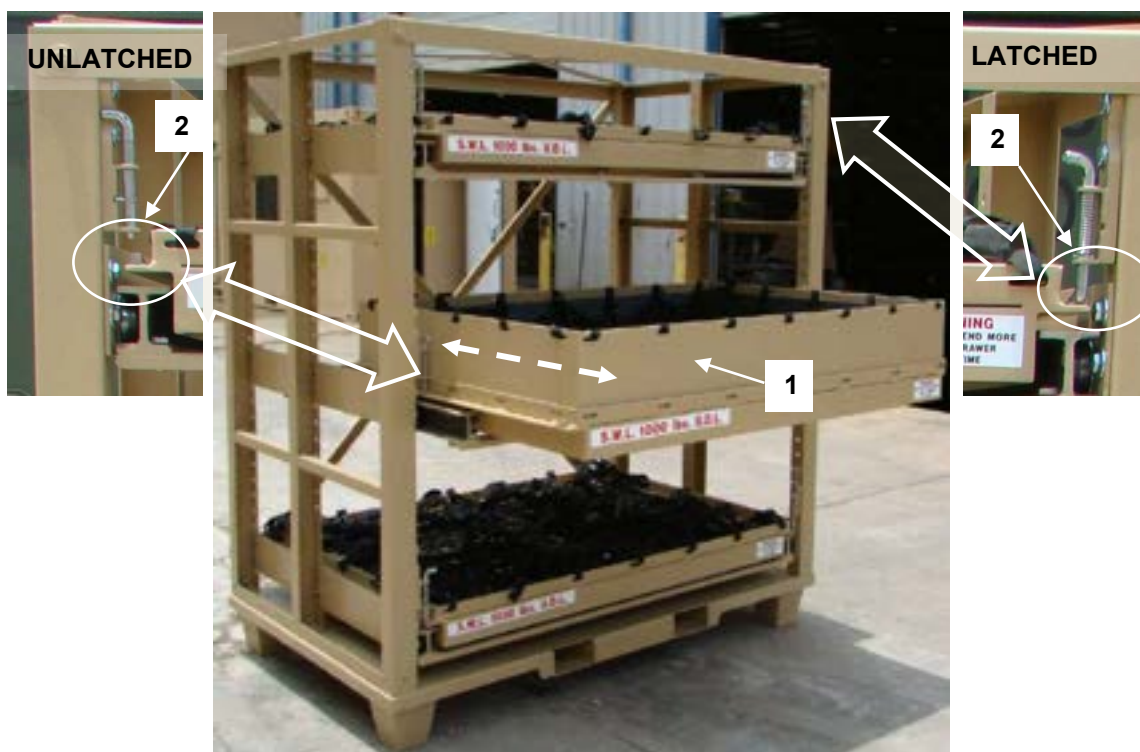

The FPU BULK MODULE system is designed to store and ship bulk materials. Trays and battery storage bins come in 75% extension slides and have maximum capacities of 1,000 lbs. Cargo nets are provided to retain material during transportation.

The FPU BULK MODULE may be inserted into any of the FPU-8 and FPU-20 series containers.

#### WARNING



Always operate one bulk tray or bin (1) at a time and return and secure the tray or bin (1) before operating another one. Ensure that both latch bolt levers (2) are latched and the tray or bin will not roll free. Failure to do so may cause injury or damage to equipment.

0009 00-1

### Module Data Tag Location

The Bulk Storage Module data tag (1) is located at the rear bottom of the module (2).

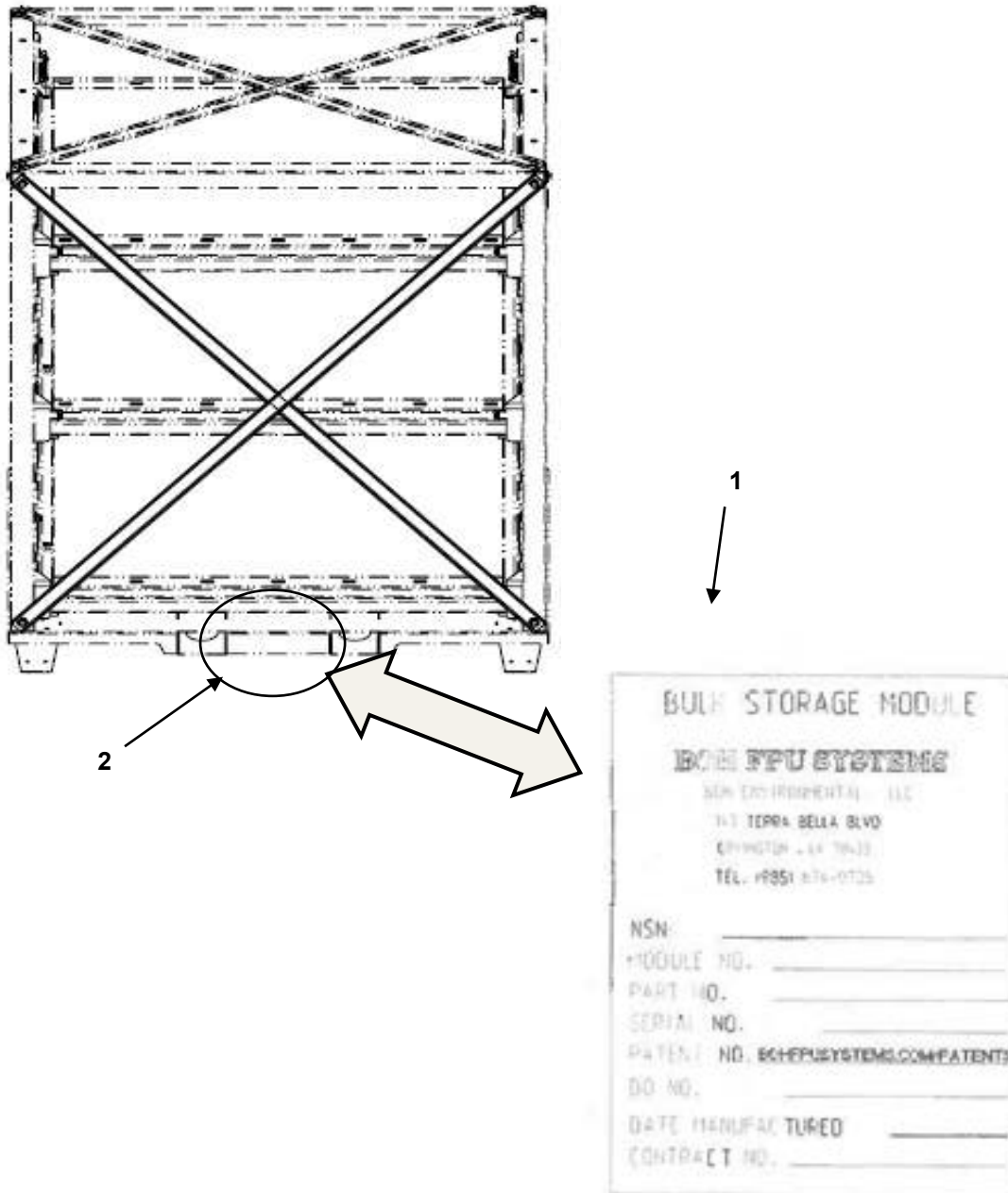

## FPU BULK STORAGE/SHIPPING MODULE

The FPU BULK MODULE is basically the hull with optional shelves that can be easily installed to fit storage and transport needs. The Trays and Bins can be easily repositioned for various height requirements. The trays can be easily adapted to an 8 inch depth bin with a simple adapter kit.

There are four standard FPU Bulk Module styles available.

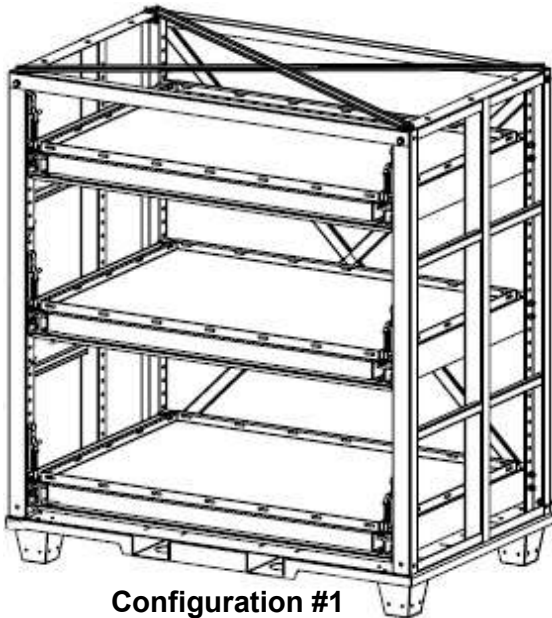

**Configuration #1**  
**Three Trays**

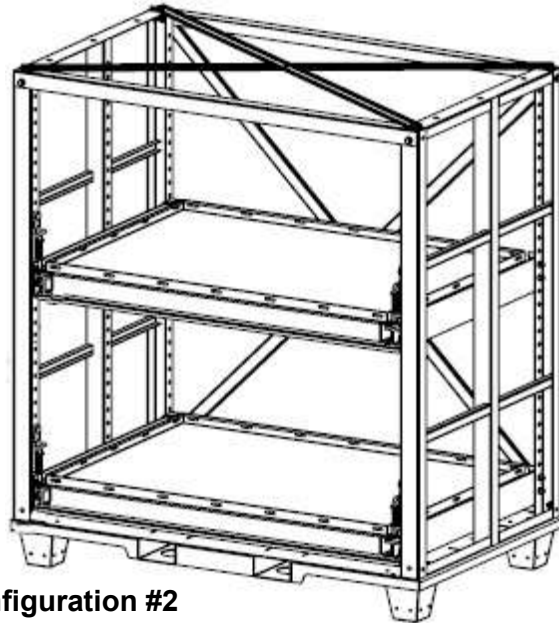

**Configuration #2**  
**Two Trays**

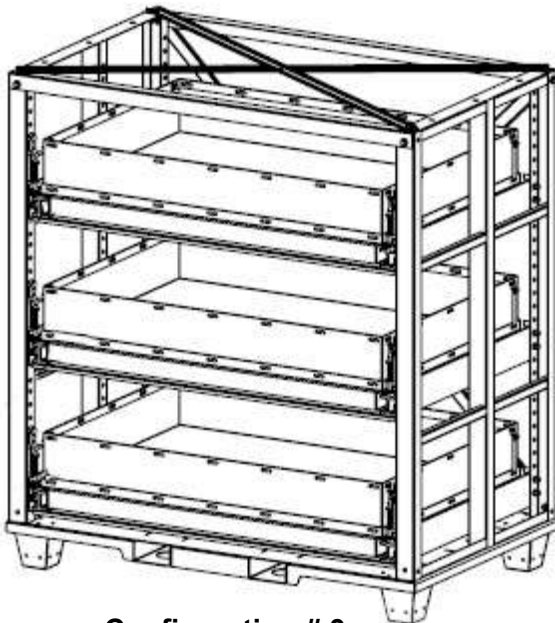

**Configuration # 3**  
**Three Bins 8" Deep**

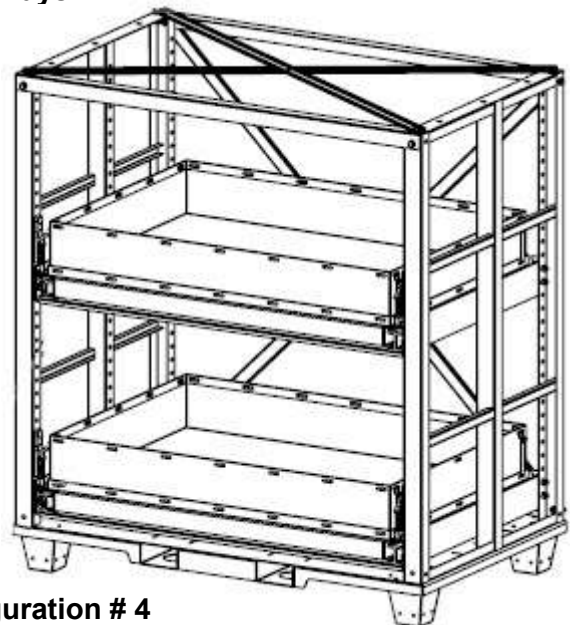

**Configuration # 4**  
**Two Bins 8" Deep**

0009 00-3

## Tray or Bin Retaining Latch bolts and Stop Cams

The drawers are retained by a left and right spring-loaded latch bolt against a front stop cam.

1. To pull the tray or bin (1) out, raise and rotate left latch bolt (2) until the pin (3) is engaged in the retaining slot and remains in the up position.
2. Retain the tray or bin (1) position with the left hand and raise the right spring loaded latch bolt (4) and pull the tray or bin forward to move the front cams (5) past both latch bolts (2 and 4).
3. Once the tray or bin front cams (5) are past the latch bolts (2 and 4), release the right latch bolt (4) and rotate the left latch bolt (2) allowing them to freely ride on the tray or bin rail, between the front (5) and rear cams (6).
4. Pull the tray or bin (1) to the full out position until the rear cams (6) flat edge engages both latch bolts (2 and 4). This will prevent the tray or bin (1) from rolling back; the frame bolts (7) and rollers act as a stop to prevent the tray or bin (1) from coming completely out of the frame.
5. To return the tray or bin (1), raise and rotate left latch bolt (2) until the pin (3) is engaged in the retaining slot and remains in the up position.
6. Retain the tray or bin (1) with the left hand and raise the right spring loaded latch bolt (4) and push the tray or bin forward to move the rear cams past the latch bolts.
7. Once the tray or bin rear cams (6) are past the right latch bolt (4), release the right latch bolt to allow it to ride freely on the rail between the front and rear cams (6).
8. Push in the tray or bin (1), until the right latch bolt (4) rides over the front cam (5).
9. Rotate the left latch bolt until the retaining pin is disengaged from the retaining slot and ensure the latch pin is seated in front of the front cam.

### NOTE

The right latch bolts (4) do not have a retaining pin and must be held in the unlatched position until they pass the front or rear cams (5 and 6).

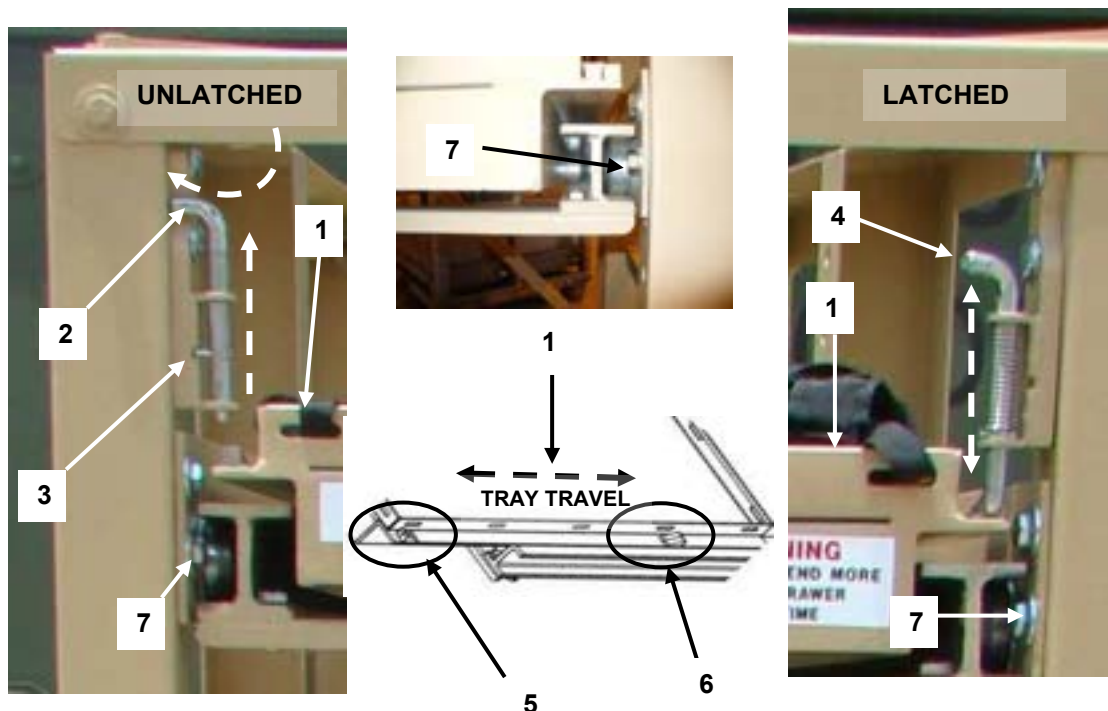

0009 00-4



## Drawer Adjustment

For drawer adjustment procedures, see Chapter 5 WP 0027.

### **WARNING**

Never remove the top spreader bar (1) or top cross members (2) as this will cause the module and drawers to become unstable. Failure to comply could cause damage to equipment, serious injury or even death.

## FPU Bulk Module Hull

The FPU Bulk Module has a sturdy hull (3) with a base with fork pockets and has side frames that have mounting holes for repositioning shelves and top and back cross bars for stability.

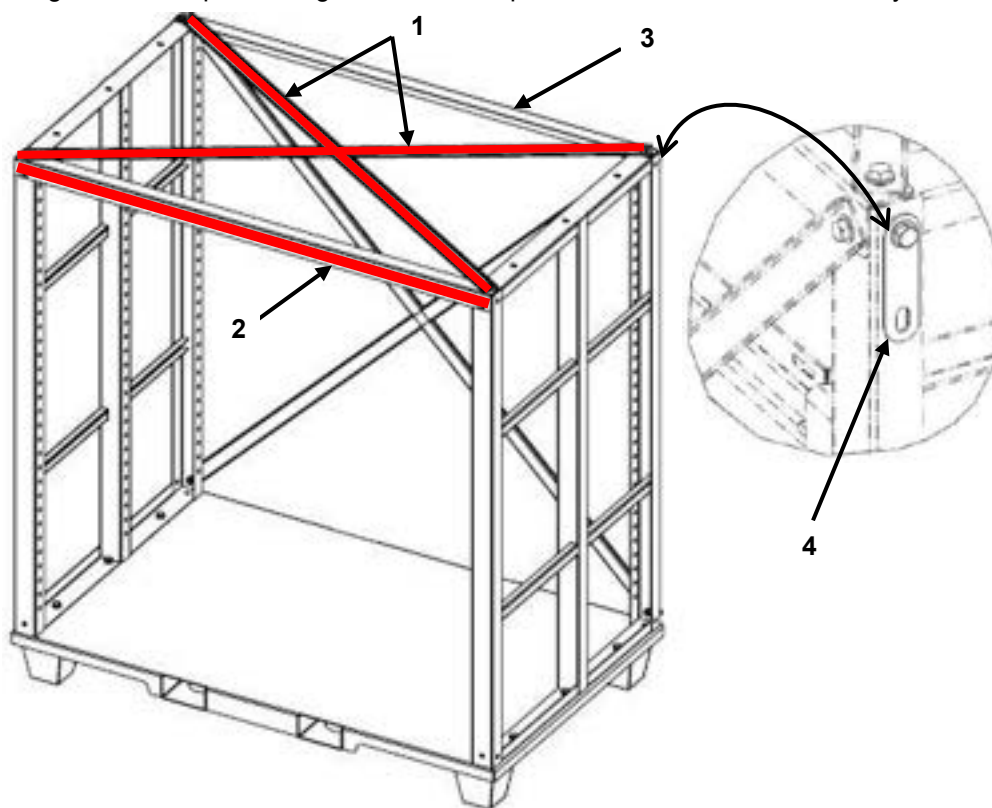

### **NOTE**

The hull (3) is provided with a rear securing bracket (4) on the right side to connect bulk modules back to back using the existing hull hardware.

## Back to Back Connection

### WARNING



In a warehouse setting, connect two FPU Bulk Modules back to back with the securing brackets (1) on the right rear to ensure a stable operating platform and prevent tipping of the unit. Always operate one tray or bin at a time and return and secure that tray or bin before operating another one. Ensure the latch bolt lever is engaged and the tray or bin will not roll free. Failure to do so may cause damage or injury.

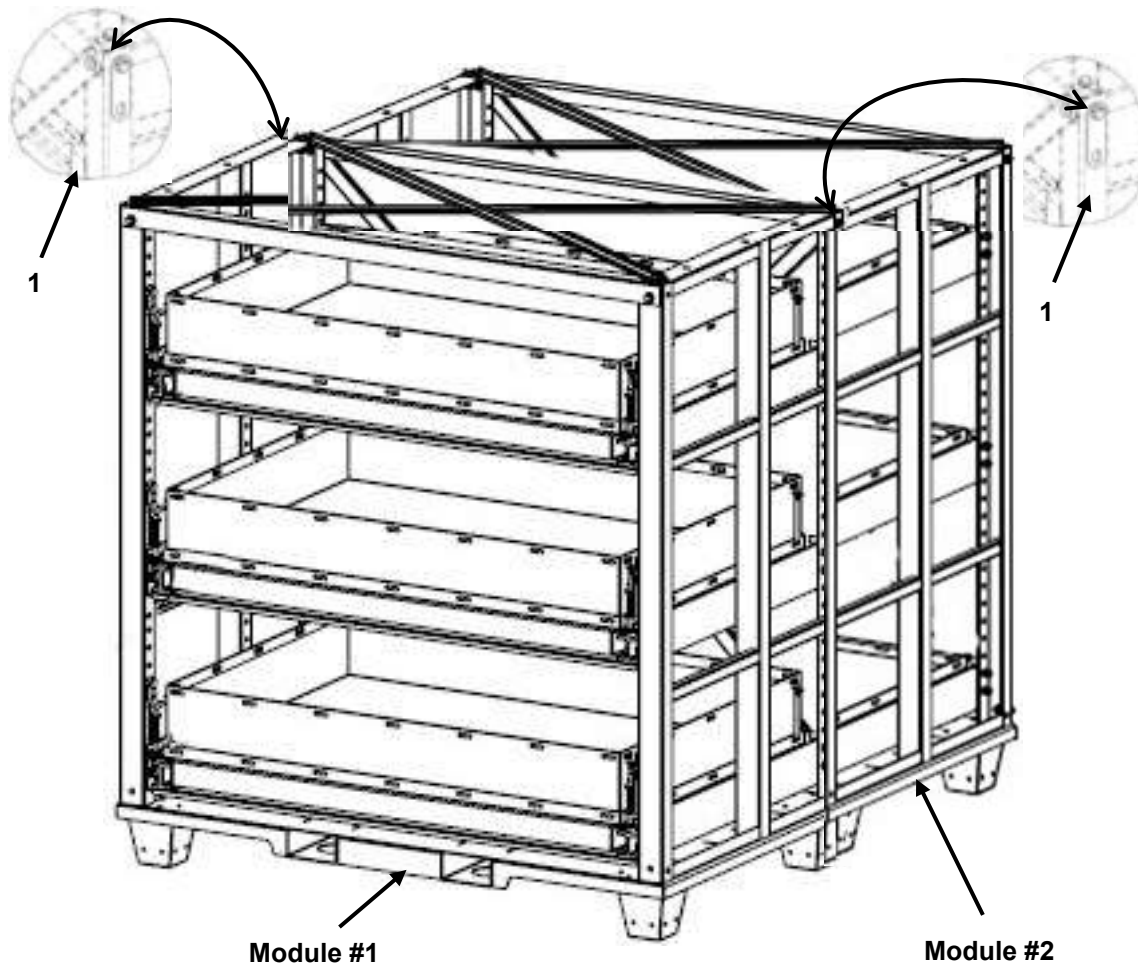

### NOTE

Each hull is provided with one rear securing bracket (1) on the right side to connect bulk modules back to back using the existing hull hardware.

0009 00-6

## Tray or bin, Roller Hull and Side walls

The trays (1) are on roller bearings within a roller frame (2), so the trays or bins can be mounted in various positions. There is a kit with mounting brackets and side walls (3) to create a depth of 8" for the conversion of a tray to a bin.

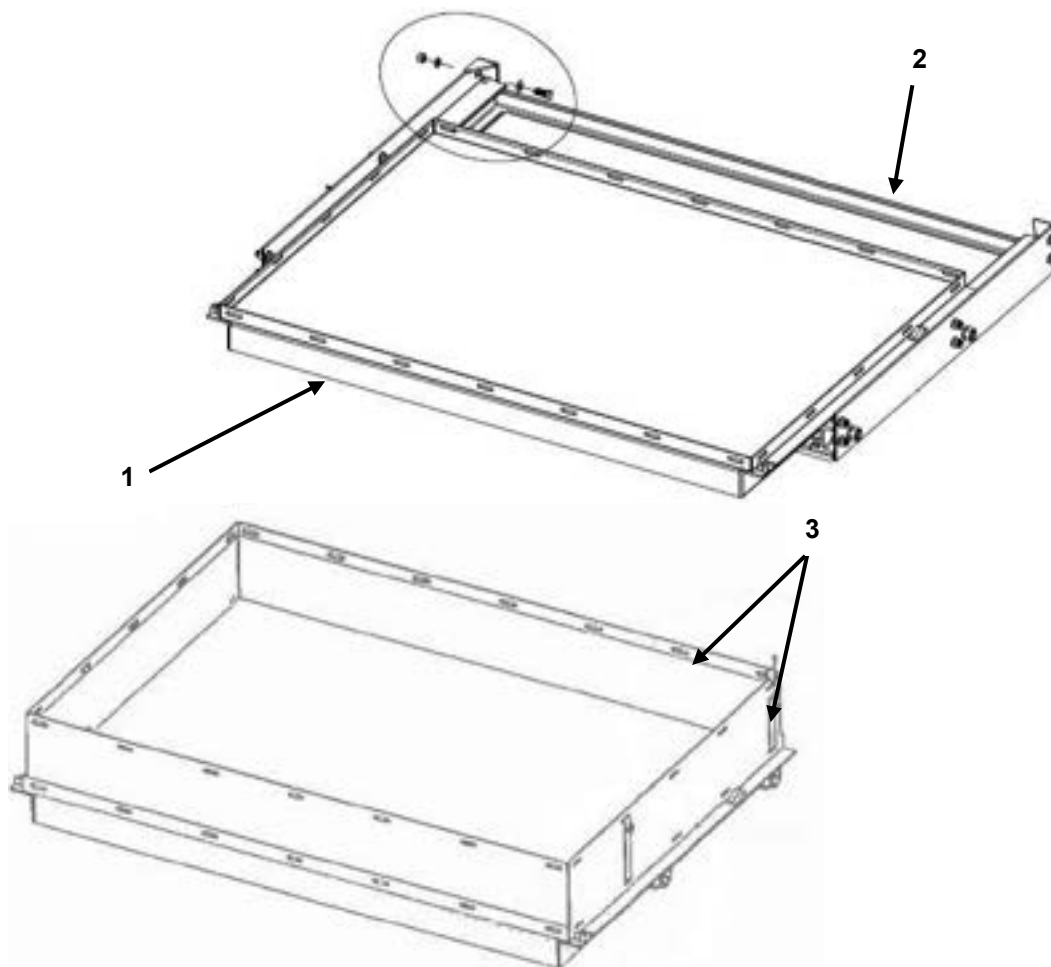

### WARNING



When storing batteries consult; Federal Specification Batteries, Storage, Industrial, Automotive, PPP-B-140C March 1, 1993

**END OF WORK PACKAGE**

0009 00-7

This page was intentionally left blank

---

## OPERATOR INSTRUCTIONS

### FPU SYSTEMS OPERATION MANUAL (INCLUDING REPAIR PARTS & SPECIAL TOOL LIST) STANDARD AND SPECIALIZED FPU MODULES BOH FPU Field Pack-up Units

#### OPERATION OF FPU TRICON CONTAINER ADAPTER

---

The FPU TRICON Adapter is designed to modify TRICON Containers to allow the installation of FPU Modules. The installation of the FPU TRICON Adapter requires no drilling or welding through use of existing TRICON cargo tie-down rings/fixtures.

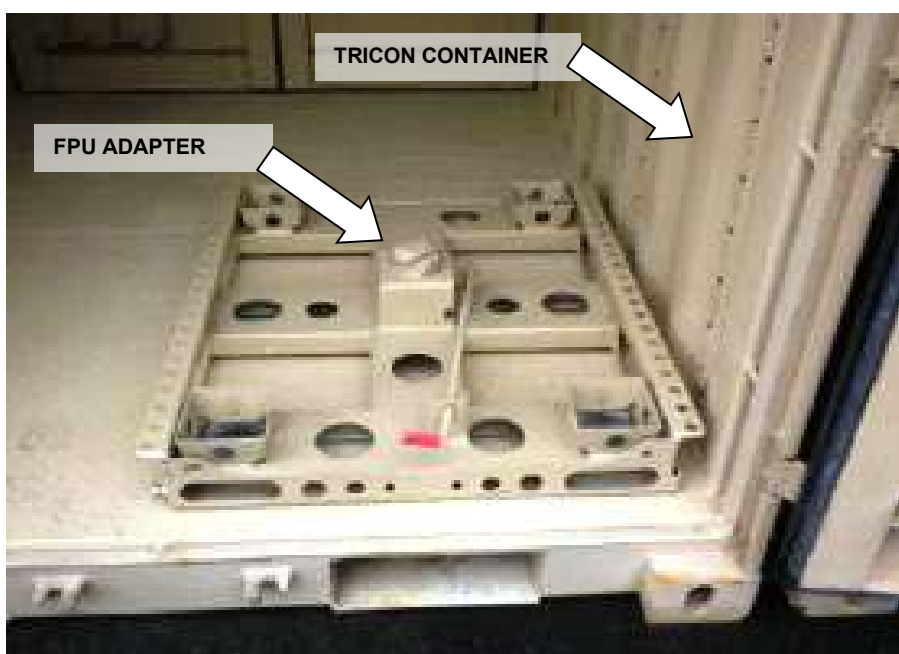

### Tricon Adapter Data Tag Location

The Tricon Adapter data tag (1) is located beneath the module lock handle (2) at the front adapter edge.

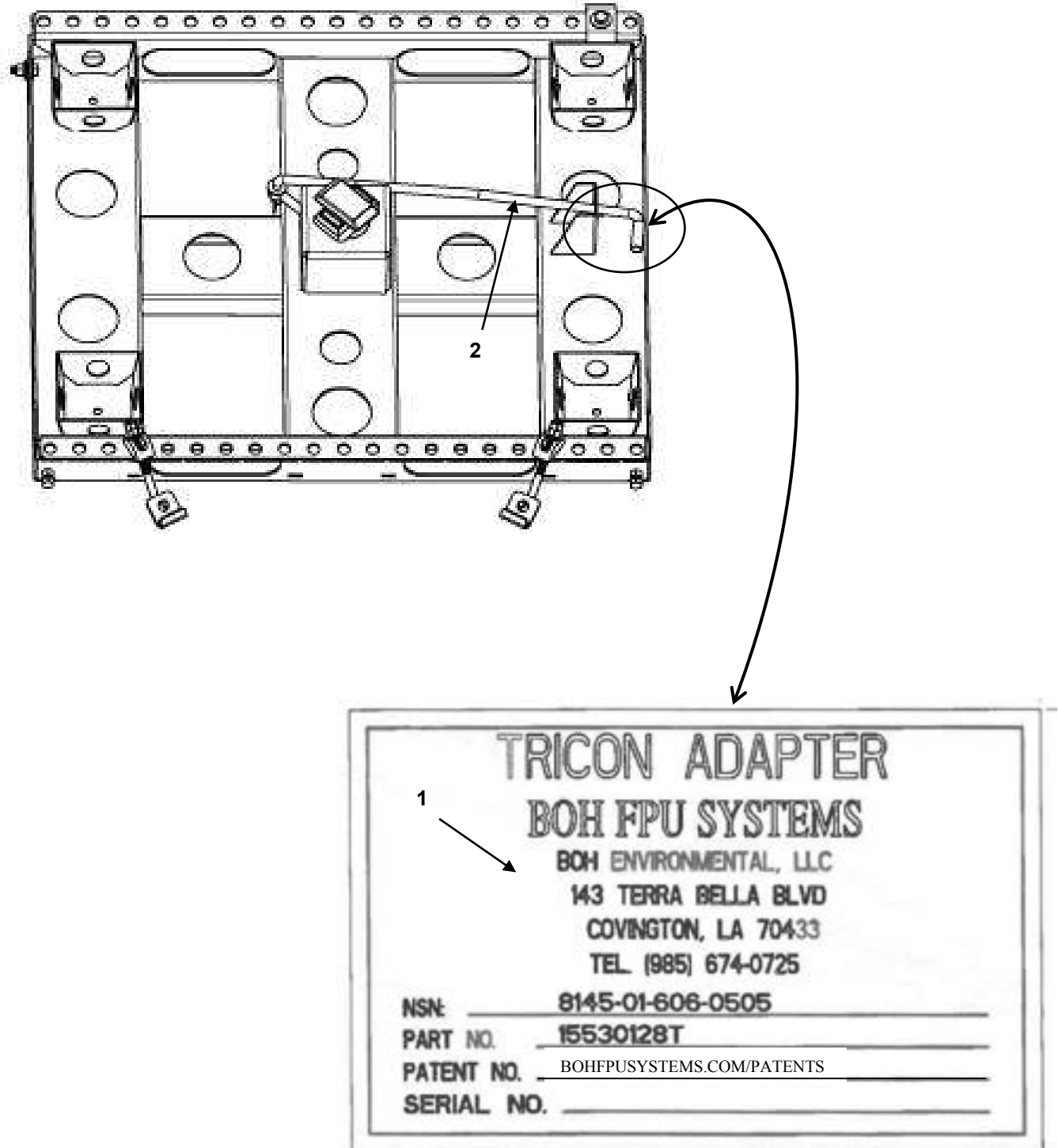

## TRICON STORAGE BRACKETS

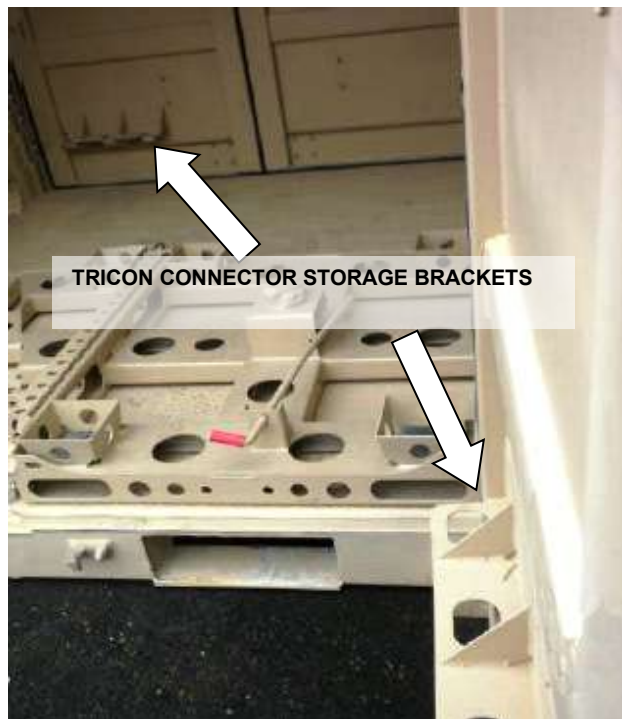

### NOTE

There are several manufacturers of TRICONS. Some models have one container connector storage bracket mounted to the inside of one door (one side of the container) and some models have two (one on both sides of the container). For models that have only one storage bracket and when installing only one pair of adapters, insure the adapters are installed on the side that do not have these brackets. When installing two pair of adapters or for models that are equipped with two storage brackets (one each side), the brackets will have to be removed to prevent interference with the FPU Storage Modules. Have maintenance cut and grind the brackets from the doors. TRICON connectors may be stored within the container.

## INSTALLING THE TRICON ADAPTERS

### WARNING



Use proper lifting techniques when lifting the TRICON Adapter. Use work gloves when handling the Adapter. Never use fingers to align the bolt holes. Ensure there is proper footing when moving, lifting or positioning the Adapter. Failure to comply may result in injury.

1. Using two personnel, lift the first adapter and place it near the wall on the right side of the container with the red release handle facing outward. Align the adapter front 2" inside the front edge of the TRICON container opening.



RED RELEASE HANDLE

2. Install jack bolt and nut in between adapters near the front and back.
3. Finger tighten bolt head until it contacts the nut.



### NOTE

Jack bolt will be extended in a later step once the second adapter is in place.



- Using two personnel, lift the second adapter and position it on the left of the first adapter with the red handle facing outward.

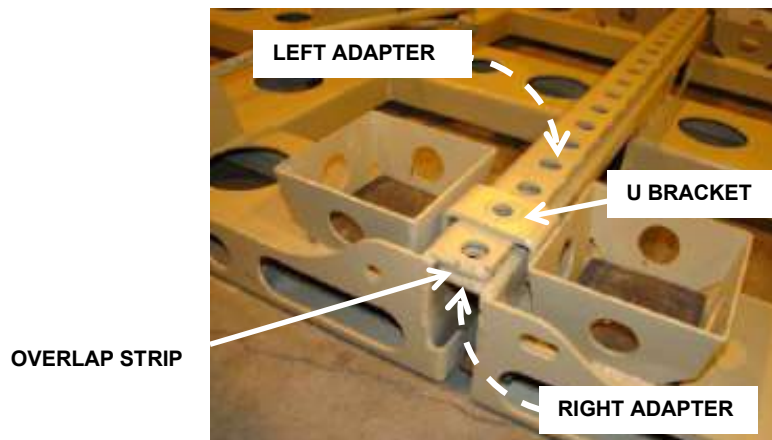

- Ensure the metal strip of the left hand adapter is positioned and overlapping the right hand adapter.
- With a metal rod or pry bar, align all the bolt holes.
- Place the connecting U bracket over the overlapping adapters.

## CONNECTING THE SECOND ADAPTER

- Align the U bracket over the second hole from the front and back.
- Align the bracket holes and place the bolts, lock washers and flat washers in the bolt holes.
- Place the flat washers and nuts underneath on the bolts and finger tighten.

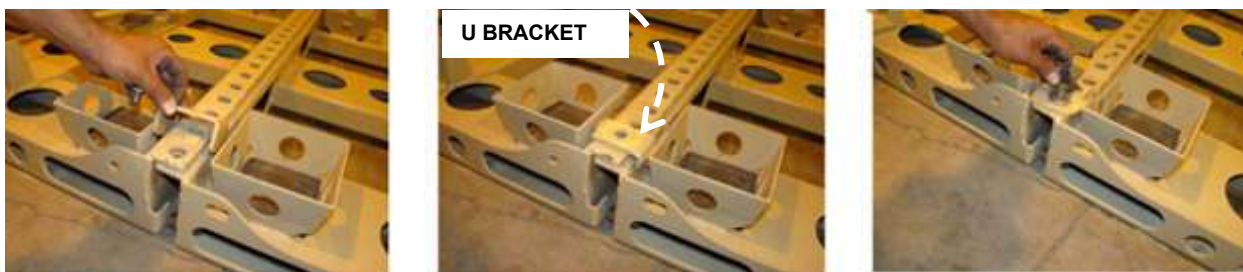

## INSTALLING THE SECOND (REAR) PAIR OF ADAPTERS (If Applicable)

0010 00-5

**NOTE**

When installing the second pair of adapters, the rear connector hardware must be removed until the adapters are in position.

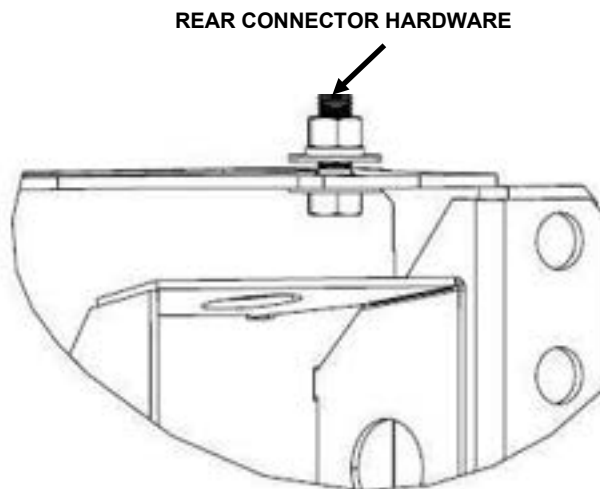

1. Repeat the above steps number 1 through 9 on the second pair of adapters.
2. When the second pair of adapters has been placed in position, reinstall the hardware and finger tighten.

**POSITIONING THE TRICON ADAPTERS**

1. Position all of the connected adapters (1 or 2 pairs) equidistant from the side wall of the TRICON Container.



2. Position each of the front corners of the adapters (1 or 2 pairs) at least 2" inside the front door edge to permit the door to close. Check dimension at left and right front corners as shown in picture.



3. When the two pairs of adapters are positioned back to back, tighten the left and right side rear connector bolts with a  $\frac{3}{4}$ " open end wrench.



Left Connection Bolt

## SECURING THE TRICON ADAPTERS

The adapters are secured to the TRICON containers that have welded tie-down points or floor rings by means of an adjustable J hook device.

### NOTE

Eight J bolts are required when installing four adapters



0010 00-7

1. When installing the J hook bolts, select a hole to tilt the device about 20 to 30 degrees toward the center.
2. Feed each J hook bolt through the hole engaging the ring and place the hillside washer, flat washer, adjustment nut and Jam nut on the bolt and finger tighten.



#### NOTE

For those TRICON containers without floor rings, hook plates are provided to attach to the side wall brackets.

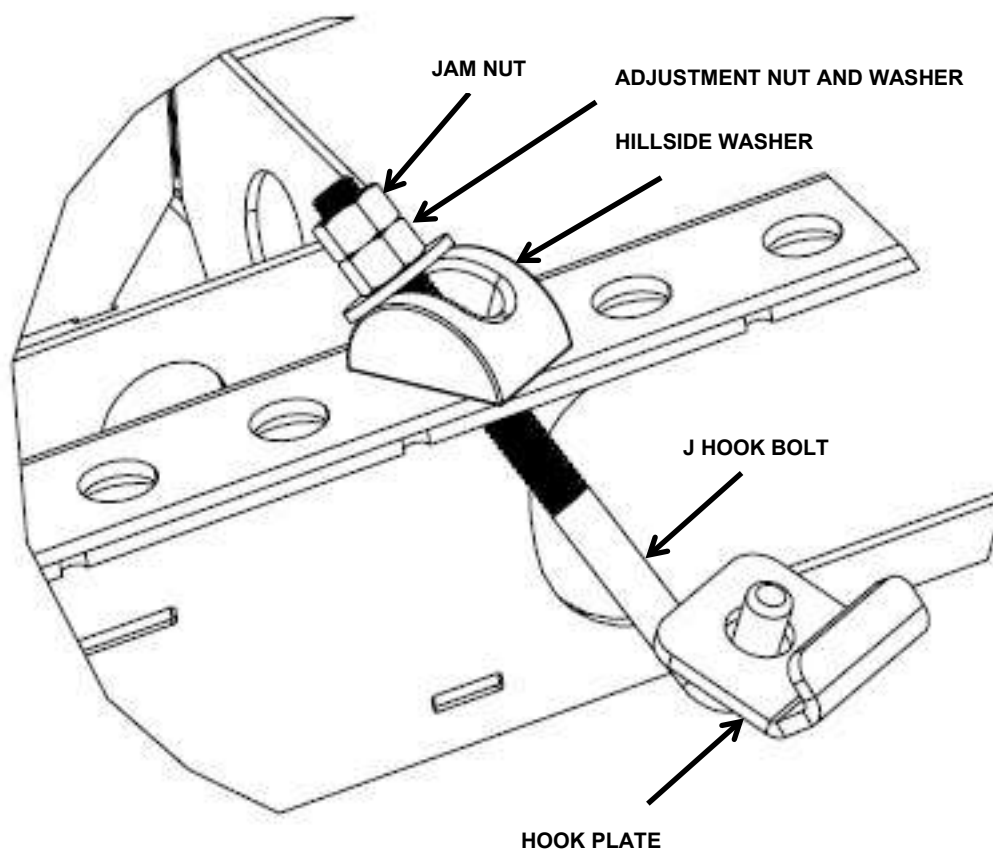

0010 00-8

3. Progressively tighten each adjustment nut on all J Bolts until the adapters are secured in place, and then tighten the jam nuts to prevent the J Bolts from loosening.
4. Verify adapters are centered in the container and tighten center U-bracket nuts.
5. Tighten J-bolt adjustment nuts using alternating pattern from both sides of the container.
6. Tighten J-bolt jam nuts.
7. With a  $\frac{3}{4}$ " open end wrench, extend each of the jack bolts with a counter clockwise rotation until the bolt is snug with the opposing adapter. This will create opposing tension between the adapters.
8. With the  $\frac{3}{4}$ " open end wrench, tighten the Jam nut to prevent the jack bolts from coming loose.

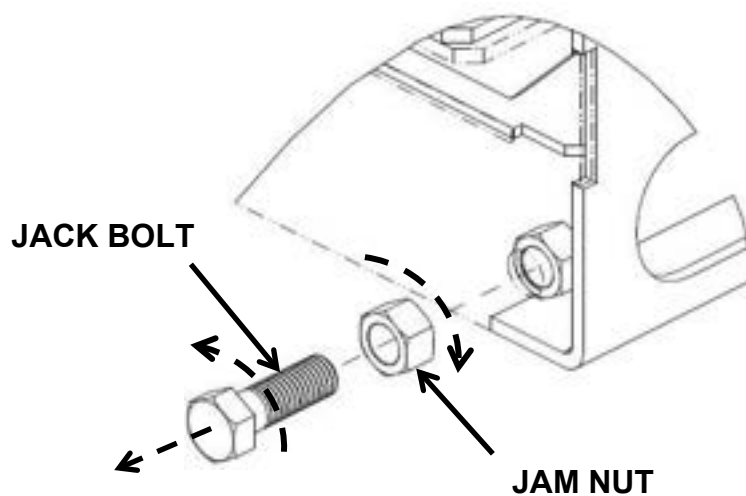
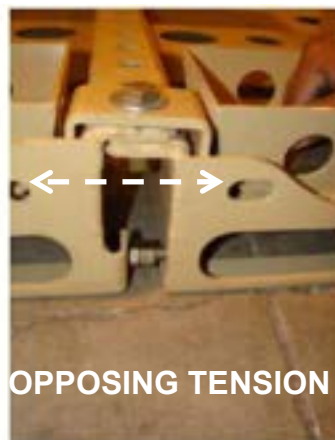
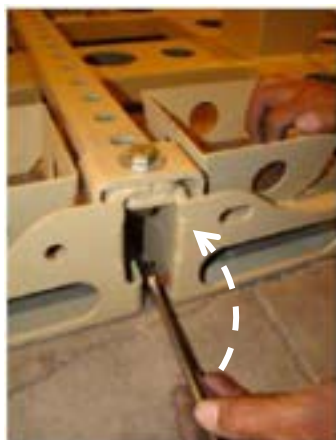

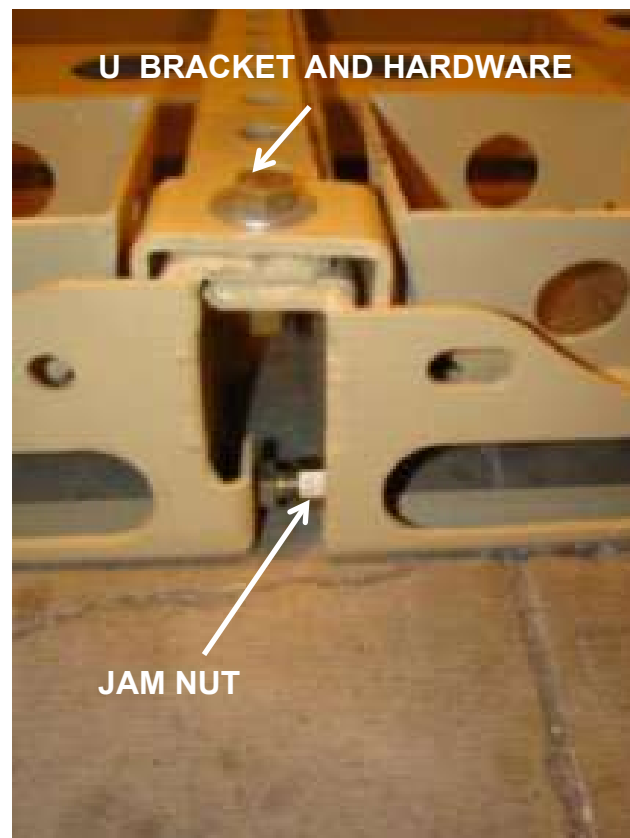

9. Check all hardware with a  $\frac{3}{4}$ " wrench to ensure that they are tight and there is no movement of the adapters.

## LOADING MODULES ONTO TRICON ADAPTERS

### WARNING



Ground guides and the MHE operators must maintain direct line of sight and insure that personnel are clear of the containers during this operation.



1. Before installing modules, pull red handle on adapters to open lock device.
2. Using ground guides, maneuver module with forklift into position and lower onto adapter.
3. Remove forklift.
4. Push in red handle to lock the module in place.
5. Repeat as necessary for loading modules onto other adapters.

### CAUTION

Inspect module to ensure it is locked in place before transport. Failure to do so may result in damage to equipment.

## END OF WORK PACKAGE

0010 00-11

This page was intentionally left blank



---

**OPERATOR INSTRUCTIONS****FPU SYSTEMS OPERATION MANUAL  
(INCLUDING REPAIR PARTS & SPECIAL TOOL LIST)  
STANDARD AND SPECIALIZED FPU MODULES  
BOH FPU Field Pack-up Units****MODULE OPERATION UNDER UNUSUAL CONDITIONS**

---

**INITIAL SETUP:**

FPU Downloaded and Operating

**Maintenance Level**

Operator/Crew

**Personnel Required**

Two (plus one supervisor)

---

**OPERATION UNDER UNUSUAL CONDITIONS**

This work package provides instructions for the operation of the FPU modules under unusual conditions. These include adverse weather, and nuclear, biological and chemical attack.

**Operation in Rain and/or Mud**

1. Provide an adequate drainage ditch to prevent standing water around the FPU modules.
2. Secure all accessories and container during extremely harsh rain.

**Operation in Hot Weather**

---

**WARNING**

---



In extreme heat, do not touch metal parts with bare hands.  
Severe skin damage may result.

**Operation in Snow, Ice, or Extreme Cold**

---

**WARNING**

---



In extreme cold, do not touch metal parts with bare hands.  
Severe skin damage may result.

0011 00-1

## Fording

The FPU modules are not watertight. They should never be submerged in any depth of water or material damage may result. When mounted on a trailer or truck, hard-bottom water crossings should be no deeper than approximately two feet. When in doubt, refer to Unit Standard Operating Procedures.

## Interim Nuclear, Biological, and Chemical (NBC) Decontamination Procedures

### WARNING



The FPU modules are NOT designed to be operated in contaminated NBC environments. Do not operate the FPU in contaminated NBC environments. If possible, cease operation of the FPU modules prior to an NBC event and close all doors.

**END OF WORK PACKAGE**

0011 00-2